

SAMPLING WITH SAMPLE AND HOLD

PREPARATION	90
A/D conversion	90
natural sampling	90
flat top sampling	90
message reconstruction by lowpass filtering	91
sample width	91
sample-and-hold sampling	92
EXPERIMENT	92
message reconstruction	93
two-tone test signal	94
aliasing	94
conclusion	95
TUTORIAL QUESTIONS	96

SAMPLING WITH SAMPLE AND HOLD

ACHIEVEMENTS: *investigation of the sample-and-hold operation as a first step towards digitization of an analog waveform. Message reconstruction by lowpass filtering.*

PREREQUISITES: *none*

ADVANCED MODULES: *INTEGRATE & DUMP*

PREPARATION

A/D conversion

Before it is possible to transmit analog information via a digital system the analog signal must first be transformed into a digital format. The *first step* in such a transformation typically involves a sampling process.

natural sampling

Natural sampling of an analog waveform (message) is examined in the experiment entitled *The sampling theorem* (within *Volume A1 - Fundamental Analog Experiments*).

Natural sampling takes a slice of the waveform, and the top of the slice preserves the shape of the waveform.

flat top sampling

A very common, and easily implemented method of sampling of an analog signal uses the sample-and-hold operation. This produces *flat top* samples.

Flat top sampling takes a slice of the waveform, but cuts off the top of the slice horizontally. The top of the slice does *not* preserve the shape of the waveform.

Figure 1 below contrasts the two methods.

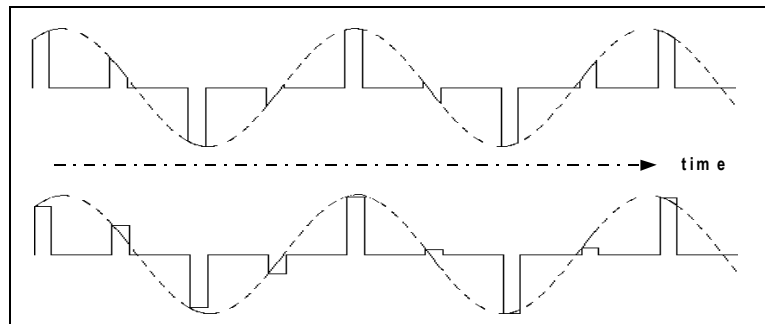

Figure 1: natural sampling (above) and flat top (below)

message reconstruction by lowpass filtering

In the experiment entitled *The sampling theorem* a simple analysis showed that there was *no distortion* of the message when reconstruction was implemented by lowpass filtering.

It will now be declared as an obvious fact:

if message reconstruction by lowpass filtering of natural samples results in no distortion, then there must be distortion when flat top pulses are involved.

Analysis of the distortion for flat top pulses will not be attempted here. Instead some observations will be made, and you can draw your own conclusions.

sample width

An important observation must be made. The pulse width determines the amount of energy in each pulse, and so can determine the amplitude of the reconstructed message. But, in a linear and noise free system, the width of the samples plays no part in determining the amount of distortion of a reconstructed message.

sample-and-hold sampling

The sample-and-hold operation is simple to implement, and is a very commonly used method of sampling in communications systems.

In its simplest form the sample is held until the next sample is taken. So it is of maximum width.

This is illustrated in Figure 2 below.

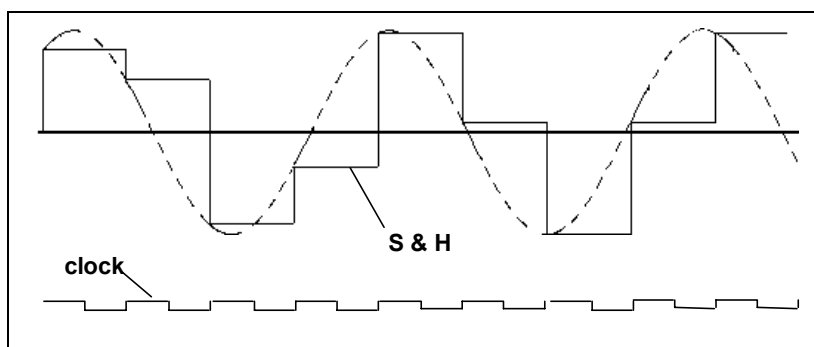

Figure 2: sampling by sample-and-hold (for full sample width)

In the above example the sampling instant is coincident with the rising edge of the clock signal.

In practice there may be a 'processing delay' before the stepped waveform is presented at the output. This is the case in the sub-system being examined in this experiment.

EXPERIMENT

There is a stand alone SAMPLE-AND-HOLD sub-system in the INTEGRATE & DUMP module. This will be used in the present experiment.

T1 acquire an INTEGRATE & DUMP module. This is a multi-purpose module. Within it is a sub-system which performs sample-and-hold operations. Before plugging it in, set the on-board switch SW1 to the S&H 1 position ('0'). Analog signals connected to the input socket labelled I&D 1 will now undergo a sample-and-hold (S&H 1) operation, the result appearing at the I&D 1 output socket. Ignore the duplicate S&H 2 option available at the I&D 2 sockets.

T2 patch up the module according to Figure 3 below.

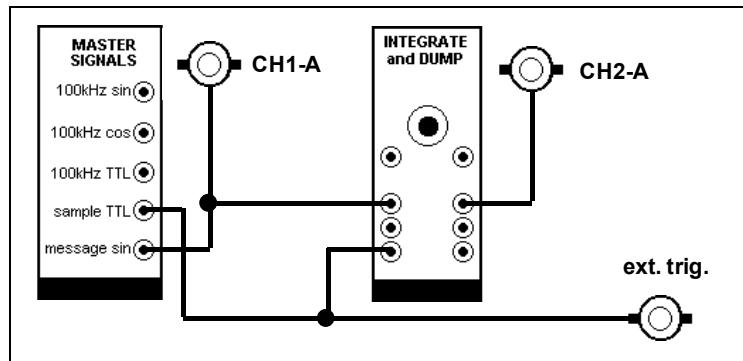

Figure 3: the TIMS model

For a stable view of both input and output it is convenient to use a message which is a submultiple of the sample clock frequency. Thus use the 2.03 kHz message (sinewave) from the MASTER SIGNALS module, together with the 8.333 kHz TTL clock.

T3 select a sweep speed to show two or three periods of the message - say 0.1 ms/cm. Set equal gains of both channels - say 1 volt/cm. With the patching shown in Figure 3 you might expect to obtain oscilloscope displays similar to that of Figure 2. Try it.

T4 note the output from the socket labelled READY. Sketch it with respect to the clock and output signal, showing time relationships.

There is a processing delay within the sample-and-hold sub-system. As a result, the two displays will be shifted relative in time. The ready signal occurs within the time during which the sample is available, and could be used to signal analog-to-digital (A/D) circuitry to start a conversion.

message reconstruction

Now that you have seen a sample-and-hold operation, you are ready to reconstruct the message from it. This is a lowpass filtering operation.

T5 use a TUNEABLE LPF module to reconstruct the message. Decide on, then set, a 'suitable' bandwidth. Report your findings. Then read on:

To what passband width did you set the filter ?

Remember, you are looking for any possible distortion components introduced by the sample-and-hold operation, and then the reconstruction process.

Since the message is at 2.03 kHz a passband of 3 kHz would be wide enough ?

Yes and no !

This would indeed be wide enough to pass the message, but it would not be wide enough to pass any harmonic distortion components.

But the filter passband could not be made wider than half the sampling frequency (else the Nyquist criterion would be violated), and that is not much more than the current message frequency. So something has to be changed.

Is a synchronous message necessary? Not any longer, after having seen the stationary sample-and-hold waveform. So why not use an AUDIO OSCILLATOR, set to its lowest frequency (about 300 Hz), and the 3 kHz LPF within the HEADPHONE AMPLIFIER module. This would give plenty of room for any distortion components to appear at the output. However, unless they are of significant amplitude, they may not be visible on the oscilloscope.

T6 *do as suggested above. Use the oscilloscope to view both the input and output sinewaves simultaneously. Synchronize the oscilloscope (externally) to the source of the message. As an engineering estimate, if the distortion is not obvious, then one could say the signal-to-distortion ratio is better than 30 dB (probably better than 40 dB).*

As well as one can judge the two waveforms are 'identical'? Could you estimate the amount of distortion introduced by the reconstruction process? See Tutorial Question Q1.

If there *was* visible distortion then one should check the 3 kHz LPF reconstruction filter - does it introduce its own distortion? Compare the message shape *before* sampling, *but via this filter*, as well as *after* reconstruction.

Could you attempt to *measure* the amount of distortion? See Tutorial Question Q2. The unwanted components will probably be hidden in the noise level; meaning the signal-to-distortion ratio is much better than 40 dB.

two-tone test signal

Testing for distortion with a single sine wave is perhaps not demanding enough. Should you try a two-tone test signal? The technique was introduced in the experiment entitled *Amplifier overload* (within *Volume A2 - Further & Advanced Analog Experiments*).

aliasing

With the 3 kHz LPF as the reconstruction filter, and an 8.333 kHz sample rate, there should be no sign of aliasing distortion.

To demonstrate aliasing distortion:

T7 *replace the 8.333 kHz sampling signal from the MASTER SIGNALS module with the TTL output from a VCO. Monitor the VCO frequency with the FREQUENCY COUNTER. Starting with the VCO set to its highest frequency on the LO range (about 15 kHz), slowly reduce it, while watching the reconstructed message waveshape. As soon as distortion is evident note the VCO frequency. Knowing the reconstruction filter amplitude characteristic, how does this agree with the Nyquist criterion? See Tutorial Question Q3.*

conclusion

You have seen that the sample-and-hold operation followed by a lowpass filter can reconstruct the signal, whose samples were taken, with ‘good’ accuracy. If you had available a spectrum analyser, or its equivalent, you would have been able to show that unwanted components were at least 40 dB below the wanted components when implemented with TMS modules operating within their limits. So, for communications purposes, we might say message reconstruction is distortionless.

The sampling process is the first of two major steps in preparing an analog message for digital transmission. The second step is conversion of the sampled waveform to a series of digital numbers. This introduces a second source of distortion, due to the need for *quantization*. But quantization distortion can also be made negligible if sufficient quantization levels are used.

Sample-and-hold followed by amplitude quantization is examined in the experiments entitled *PCM encoding* and *PCM decoding* in this Volume.

TUTORIAL QUESTIONS

- Q1* assuming a sinewave is accompanied by a small third harmonic component, how large would this have to be before its presence could be detected using only an oscilloscope? This question would not please the purists, because it raises more questions than it asks. But attempt an answer. You could even set up the signal using TIMS and **demonstrate** your reply.
- Q2* recall the experiment entitled **Modelling an equation** within Volume A1 - Fundamental Analog Experiments. There was demonstrated the cancellation of a component in a signal. Describe how this technique might be used in the present case to make a measurement of signal-to-distortion ratio.
- Q3* define the 'slot bandwidth' of a lowpass filter. Redefine the Nyquist criterion in terms of practical filter characteristics ¹.
- Q4* sample-and-hold (flat-top sampling) can be shown to introduce distortion of the message if it is reconstructed by using a lowpass filter alone. From your general reading, or otherwise, is it possible to eliminate this distortion by further message processing? **hint:** key words are aperture effect, sinc/x correction.

¹ filter characteristics are defined in Appendix A of Volume A1.