

FSK - FREQUENCY SHIFT KEYING

PREPARATION	60
generation	60
bandwidth	61
demodulation	61
asynchronous	62
synchronous	62
phase locked loop	63
post-demodulation processing	63
comments	63
EXPERIMENT	64
T1.0 generation	64
T1.1 scheme #1	64
T1.1 scheme #2	65
T1.0 demodulation	65
T1.1 signals for demodulation	66
T1.1 asynchronous receiver	66
T1.1 synchronous receiver	67
T1.1 PLL - phase locked loop	67
TUTORIAL QUESTIONS	68

FSK - FREQUENCY SHIFT KEYING

ACHIEVEMENTS: *generation and demodulation of a binary FSK signal.*

PREREQUISITES: *it would be advantageous to have completed some of the Part I experiments involving linear modulation and demodulation.*

EXTRA MODULES: *a second VCO, BIT CLOCK REGEN. Optionally, a UTILITIES and a TUNEABLE LPF.*

PREPARATION

generation

As its name suggests, a frequency shift keyed transmitter has its frequency shifted by the message.

Although there could be more than two frequencies involved in an FSK signal, in this experiment the message will be a binary bit stream, and so only two frequencies will be involved.

The word 'keyed' suggests that the message is of the 'on-off' (mark-space) variety, such as one (historically) generated by a morse key, or more likely in the present context, a binary sequence. The output from such a generator is illustrated in Figure 1 below.

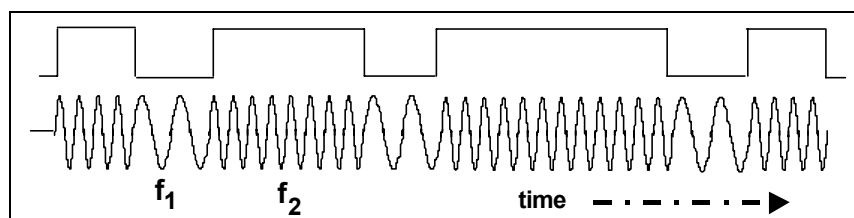

Figure 1: an FSK waveform, derived from a binary message

Conceptually, and in fact, the transmitter could consist of two oscillators (on frequencies f_1 and f_2), with only one being connected to the output at any one time. This is shown in block diagram form in Figure 2 below.

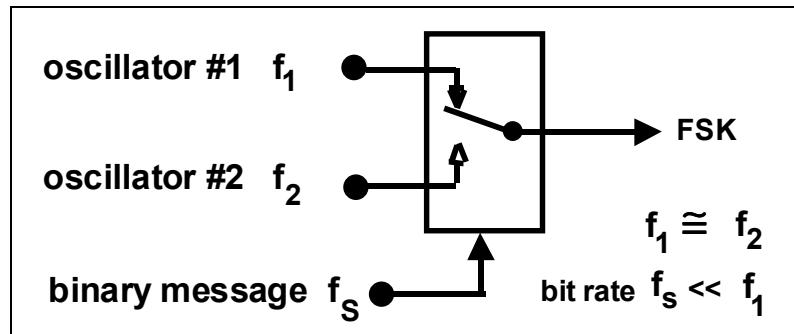

Figure 2: an FSK transmitter

Unless there are special relationships between the two oscillator frequencies and the bit clock there will be abrupt phase discontinuities of the output waveform during transitions of the message.

bandwidth

Practice is for the tones f_1 and f_2 to bear special inter-relationships, and to be integer multiples of the bit rate. This leads to the possibility of continuous phase, which offers advantages, especially with respect to bandwidth control.

Alternatively the frequency of a single oscillator (VCO) can be switched between two values, thus guaranteeing continuous phase - CPFSK. See Tutorial Question Q2.

The continuous phase advantage of the VCO is not accompanied by an ability to ensure that f_1 and f_2 are integer multiples of the bit rate. This would be difficult (impossible ?) to implement with a VCO. See Tutorial Question Q3.

Being an example of non-linear modulation, calculation of the bandwidth of an FSK signal is a non-trivial exercise. It will not be attempted here.

See Tutorial Question Q1.

FSK signals can be generated at baseband, and transmitted over telephone lines (for example). In this case, both f_1 and f_2 (of Figure 2) would be audio frequencies. Alternatively, this signal could be translated to a higher frequency. Yet again, it may be generated directly at 'carrier' frequencies.

demodulation

There are different methods of demodulating FSK. A natural classification is into synchronous (coherent) or asynchronous (non-coherent).

Representative demodulators of these two types are the following:

asynchronous

A close look at the waveform of Figure 1 reveals that it is the sum of two amplitude shift keyed (ASK) signals. These signals were examined in the experiment entitled *ASK - amplitude shift keying* in this Volume.

The receiver of Figure 3 takes advantage of this. The FSK signal has been separated into two parts by bandpass filters (BPF) tuned to the MARK and SPACE frequencies.

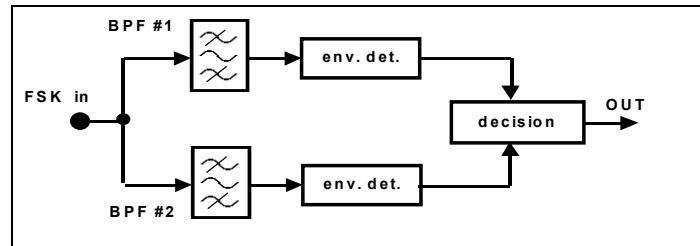

Figure 3: demodulation by conversion-to-ASK

The output from each BPF looks like an amplitude shift keyed (ASK) signal.

These can be demodulated asynchronously, using the envelope. The envelope detector is examined in the experiment entitled *Envelope recovery* within *Volume A1 - Fundamental Analog Experiments*.

The decision circuit, to which the outputs of the envelope detectors are presented, selects the output which is the most likely one of the two inputs. It also re-shapes the waveform from a bandlimited to a rectangular form.

This is, in effect, a two channel receiver. The bandwidth of each is dependent on the message bit rate. There will be a minimum frequency separation required of the two tones.

hint

You are advised to read ahead, *before* attempting the experiment, to consider the modelling of this demodulator. Unlike most TIMS models, you are *not* free to choose parameters - particularly frequencies. If they are to be tuned to *different* frequencies, then one of these frequencies must be 2.083 kHz (defined as the MARK frequency). This is a restriction imposed by the BIT CLOCK REGEN module, of which the BPF are sub-systems. As a result of this, most other frequencies involved are predetermined. Make sure you appreciate why this is so, then decide upon:

- bit clock rate
- SPACE frequency
- envelope detector LPF characteristics

synchronous

In the block diagram of Figure 4 two local carriers, on each of the two frequencies of the binary FSK signal, are used in two synchronous demodulators. A decision circuit examines the two outputs, and decides which is the most likely.

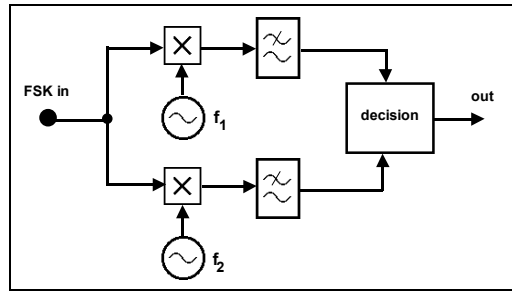

Figure 4: synchronous demodulation

This is, in effect, a two channel receiver. The bandwidth of each is dependent on the message bit rate. There will be a minimum frequency separation required of the two tones. This demodulator is more complex than most asynchronous demodulators.

phase locked loop

A phase locked loop is a well known method of demodulating an FM signal. It is thus capable of demodulating an FSK signal. It is examined in the experiment entitled *FM demodulation with the PLL* within *Volume A2 - Further & Advanced Analog Experiments*. It is shown, in block diagram form, in Figure 5 below.

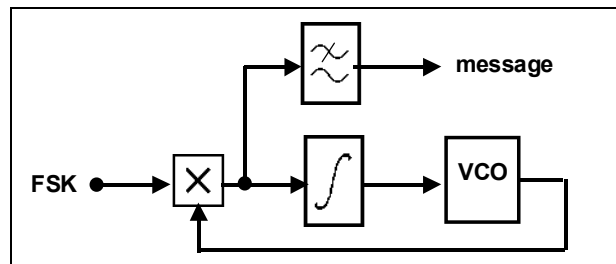

Figure 5: phase locked loop demodulator

The control signal, which forces the lock, is a bandlimited copy of the message sequence. Depending upon the bandwidth of the loop integrator, a separate LPF will probably be required (as shown) to recover the message.

post-demodulation processing

The output of a demodulator will typically be a bandlimited version of the original binary sequence. Some sort of decision device is then required to regenerate the original binary sequence. This is shown in the block diagrams above, but has not been implemented in the TIMS models to follow.

comments

One might imply, from all of the above, that the generation and demodulation of an FSK signal is relatively trivial, and that there is not a lot more to know about its properties. Such is not the case.

Extensive research has been carried out into the properties of an FSK signal. This includes the determination of the optimum relationship between the frequencies of the two tones and the data rate. You should refer to your text book for more information.

EXPERIMENT

This experiment is not typical. There are no specific tasks to be completed. Instead you are invited to investigate any or all of the models below in your own way.

Various methods of FSK generation are possible with TIMS, and some suggestions follow.

In all of the modulation schemes the message will be derived from a pseudo random binary SEQUENCE GENERATOR.

T1.0 generation

T1.1 scheme #1

A VCO module is ideally suited for the generation of a continuous phase FSK signal, as shown in Figure 6.

In FSK mode the VCO is keyed by the message TTL sequence. Internal circuitry results in a TTL HI switching the VCO to frequency f_1 , while a TTL LO switches it to frequency f_2 . These two frequencies may be in the audio range (front panel toggle switch LO), or in the 100 kHz range (front panel toggle switch HI).

The frequencies f_1 and f_2 are set by the on-board variable resistors RV8 and RV7 respectively, while a continuous TTL HI or a TTL LO is connected to the DATA input socket.

In FSK mode neither of the front panel rotary controls of the VCO is in operation.

See Tutorial Question Q2.

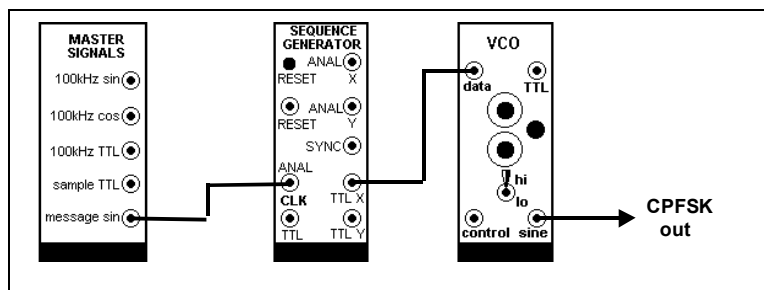

Figure 6: CPFSK

T1.2 scheme #2

Figure 7 shows a model of the arrangement of Figure 2. It switches either one of two tones to the output, in response to the message sequence.

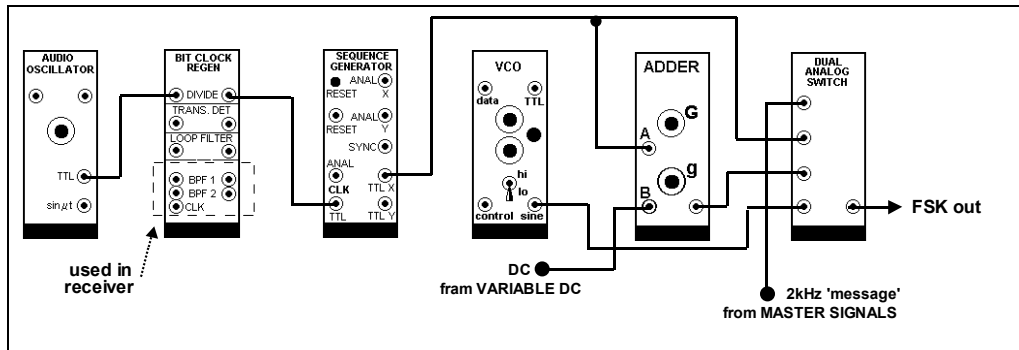

Figure 7: a model of the arrangement of Figure 2

The binary sequence is shown clocked by a divided-by-8 version of the output of an AUDIO OSCILLATOR. This oscillator cannot itself be tuned to this relatively low (for TIMS) frequency. The DIVIDE-BY-8 sub-system is in the BIT CLOCK REGEN module (set the on-board switch SW2 with both toggles DOWN).

The signals at f_1 and f_2 are provided by the 2.083 kHz MESSAGE from the MASTER SIGNALS module, and a VCO, respectively¹. The DUAL AUDIO SWITCH module is used to switch between them.

- one of the two ANALOG SWITCHES is driven directly by the TTL binary message sequence.
- the other ANALOG SWITCH is driven by the same TTL sequence, reversed in polarity, and then DC shifted by +5 volts. The reversal and DC shift is performed by the ADDER, with a maximum -ve output from the VARIABLE DC module. Although 5 volt signals exceed the TIMS ANALOG REFERENCE LEVEL the ADDER design is such that it will not be overloaded.

Unless there is already an FSK signal available at TRUNKS, this transmitter is to be used in conjunction with an asynchronous demodulator, of the type illustrated in Figure 3, and modelled in Figure 8 - so don't strip it down unnecessarily.

T2.0 demodulation

In the receivers described below it is assumed there is no bandlimiting (or noise) introduced by a channel. In the case of poor signal-to-noise ratio the MARK and SPACE signals would need to be compared in a decision circuit and the most likely one presented to the output.

¹ one or more of the above signals may be available at TRUNKS.

T2.1 signals for demodulation

The demodulators to be examined will require FSK signals as inputs. These may exist at TRUNKS - check.

If not, then you will need to generate your own.

For a suitable FSK test signal you could use the model of Figure 7. The MARK signal is pre-set to 2.083 kHz; initially set the SPACE to about 3 kHz.

T2.2 asynchronous receiver

An example of this is the demodulator of Figure 3, shown modelled in Figure 8.

The demodulator requires two bandpass (BPF) filters, tuned to the MARK and SPACE frequencies. Suitable filters exist as sub-systems in the BIT CLOCK REGEN module. These are described in the experiment entitled *Digital utility sub-systems* (within *Volume D2 - Further & Advanced Digital Experiments*).

To prepare the filters it is necessary to set the on-board switch SW1. Put the left hand toggle UP, and right hand toggle DOWN. This tunes BPF1 to 2.083 kHz, and BPF2 anywhere in the range $1 < f_0 < 5$ kHz, depending on the VCO (the filter centre frequency will be 1/50 of the VCO frequency).

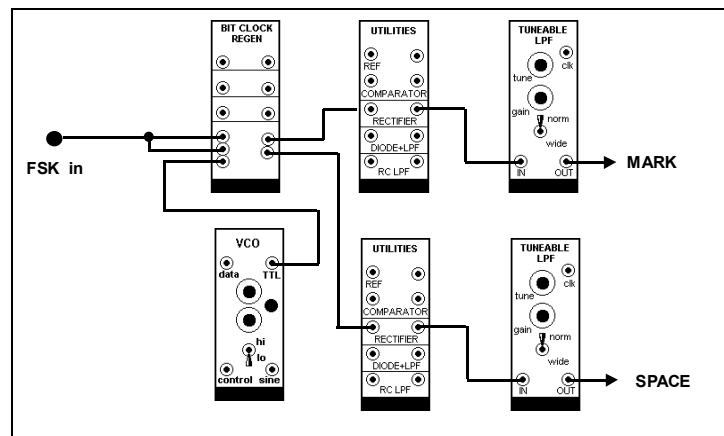

Figure 8: a model of the receiver of Figure 3

If you do not have extra UTILITIES and TUNEABLE LPF modules, then complete just one arm of the demodulator.

Alignment requires the BPFs to be tuned to the MARK and SPACE frequencies. The first is already done (2.083 kHz is already pre-set with SW1); the other is set with the VCO (already pre-set with SW2).

Note that the specified bit rate is, by TIMS standards, rather low. The average oscilloscope display can be a little flickery. Use a short sequence, and the SYNC signal from the SEQUENCE GENERATOR to ext. trig.

- what would happen if the bit rate was speeded up ?
- what would happen if the frequency of the SPACE signal, at the transmitter, was moved towards 2.083 kHz ? Of course, the receiver BPF2 would need to be retuned.

After successfully demodulating the MARK and the SPACE:

- test your preparatory work and show how close the MARK / SPACE frequencies can approach before performance is degraded - explain why this is so.
- predict what will happen if the bit rate is increased. If you have supplied your own FSK signal then you should test your prediction.

T2.3 synchronous receiver

A synchronous receiver of Figure 4 requires two local carriers, locked to the MARK and SPACE frequencies. Such a receiver would require two VCO and associated modules, and is probably too ambitious to attempt as part of this experiment.

T2.4 PLL - phase locked loop

A phase locked loop is shown in block diagram form in Figure 5, and modelled in Figure 9.

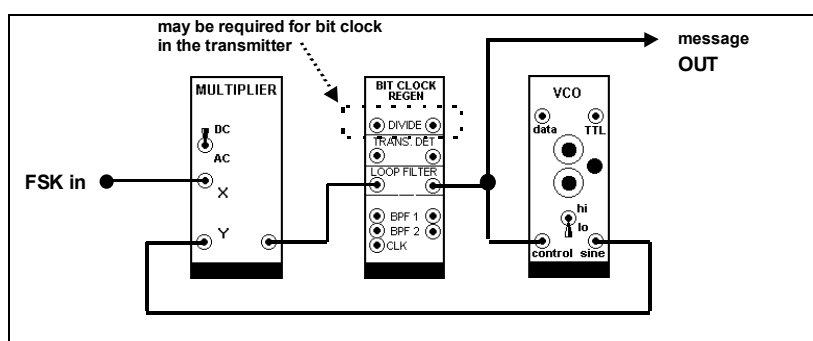

Figure 9: PLL demodulator - the model of Figure 5

The PLL is examined in the experiment entitled *FM demodulation with the PLL* (within *Volume A2 - Further & Advanced Analog Experiments*).

For the present experiment the integrator (of Figure 5) is modelled with the LOOP FILTER in the BIT CLOCK REGEN module. This module contains four independent sub-systems. The DIVIDE-BY-8 sub-system may already be in use at the transmitter.

If you are fussy about the appearance of the demodulated output it can be further filtered; say with the LPF in the HEADPHONE AMPLIFIER.

Could you use either the DECISION MAKER, or the COMPARATOR in the UTILITIES modules, or the HARD LIMITER in the DELTA MODULATION UTILITIES module, to regenerate the message as a clean TTL sequence ?

TUTORIAL QUESTIONS

- Q1 analysis of the spectrum of an FM signal (an example of non-linear modulation) is not trivial. For the case where the FSK signal can be looked upon as the sum of two ASK signals (example of linear modulation), what can you say about its frequency spectrum ?*
- Q2 the VCO is a very convenient method of making FSK - in fact, CFSK. VCOs come as low-cost integrated circuits, and their modulation characteristic allow wideband FM. However, for communications applications, they have one serious shortcoming. For example ?*
- Q3 what advantage is there in making the frequencies of the two tones of an FSK signal, and the bit rate, sub-multiples of some reference frequency ?*
- Q4 given the bandwidths of a pair of BPFs, what would determine the frequency separation of the two tones f_1 and f_2 , and the message bit rate f_s , in a receiver such as illustrated in Figure 3 ?*
- Q5 what are some of the factors which might determine the choice of either a synchronous or asynchronous FSK demodulator ?*
- Q6 where can one find a convenient TTL HI, and a convenient TTL LO, in TMS ?*
- Q7 consider the asynchronous receiver of Figure 3. The message could be reconstructed from the output of either envelope detector. For example, if the MARK signal is available then the SPACE signal is its complement. So why have both envelope detectors ?*