

Thursday, 1/21/21

More on the Barkhausen Stability Criterion

Typically, $A(j\omega)$ may just be a constant gain while $\beta(j\omega)$ will vary in magnitude and phase with frequency, so that the Barkhausen stability criterion is only satisfied at a single frequency.

Is the Barkhausen stability criterion truly sufficient for oscillation? Consider a purely deterministic system (i.e. no noise) where $\ddot{x} + ax = 0$. Will this system begin to oscillate?

The answer is no. The system must first be unstable (i.e. has negative damping, a pole or poles in the right half of the s-plane) for oscillations to begin and grow. At some point then, the damping should go to zero, satisfying the Barkhausen stability criterion, and the oscillations will remain at constant amplitude. For this to occur, our system has to be nonlinear so that the damping changes as a function of a parameter, such as displacement or amplitude.

Consider this normalized case: $\ddot{x} + (x^2 - 1)\dot{x} + x = 0$.

For this case, when the displacement $-1 < x < 1$, damping is negative

When $x = 1$ or $x = -1$, damping is zero

When $x > 1$ or $x < -1$, damping is positive

So in a “real world setting” where random noise (thermal noise, etc.) is present, the system will begin oscillating. Consider the Simulink model of this system shown below.

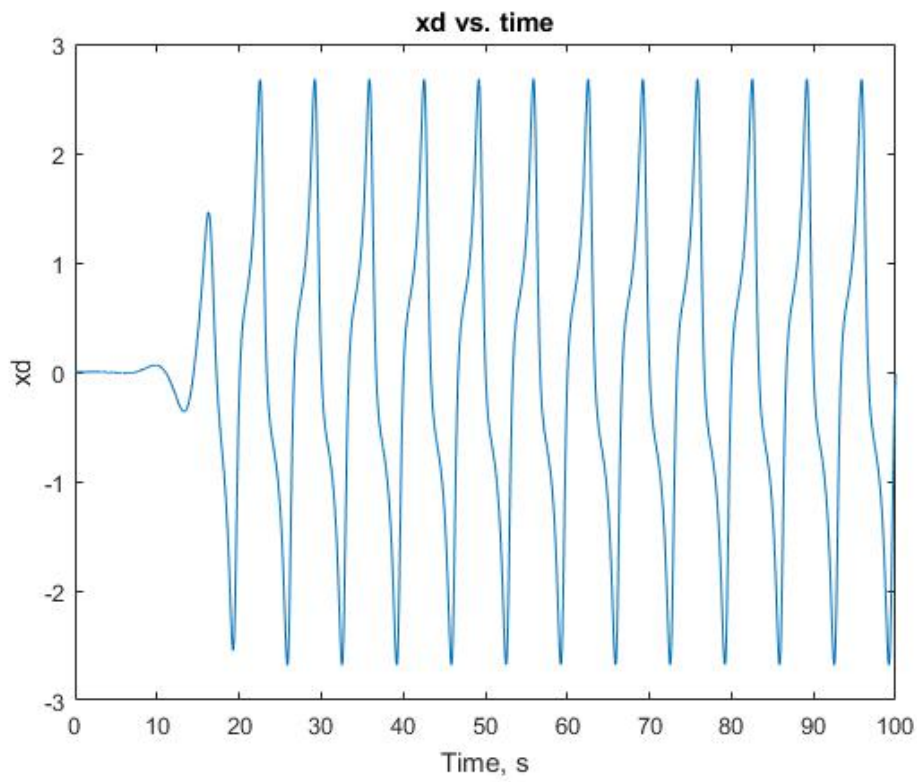
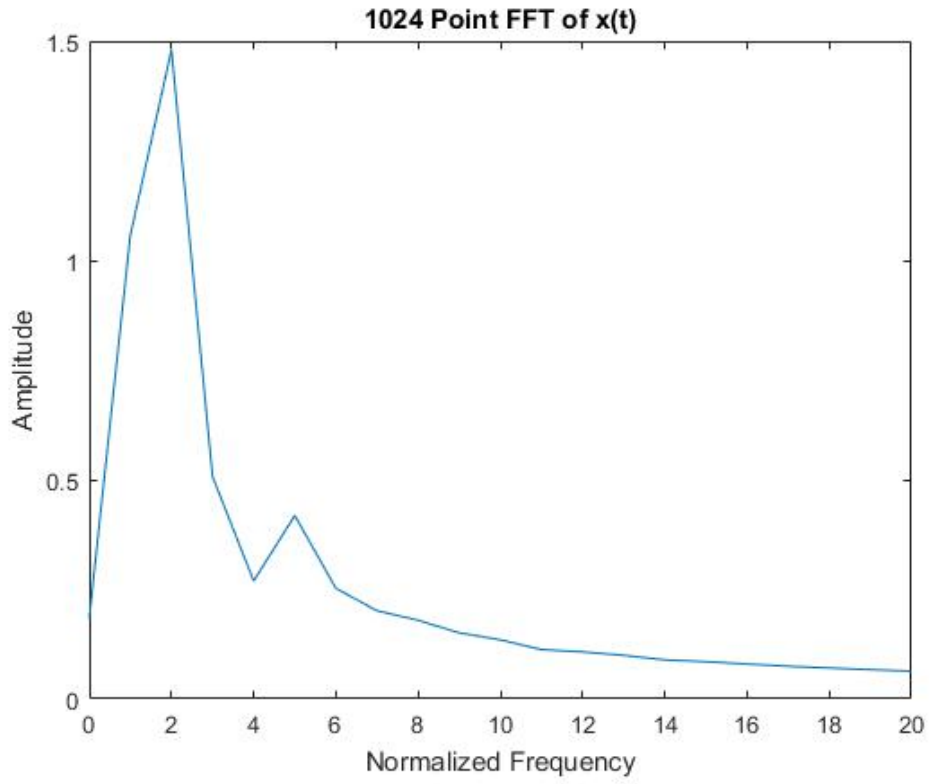

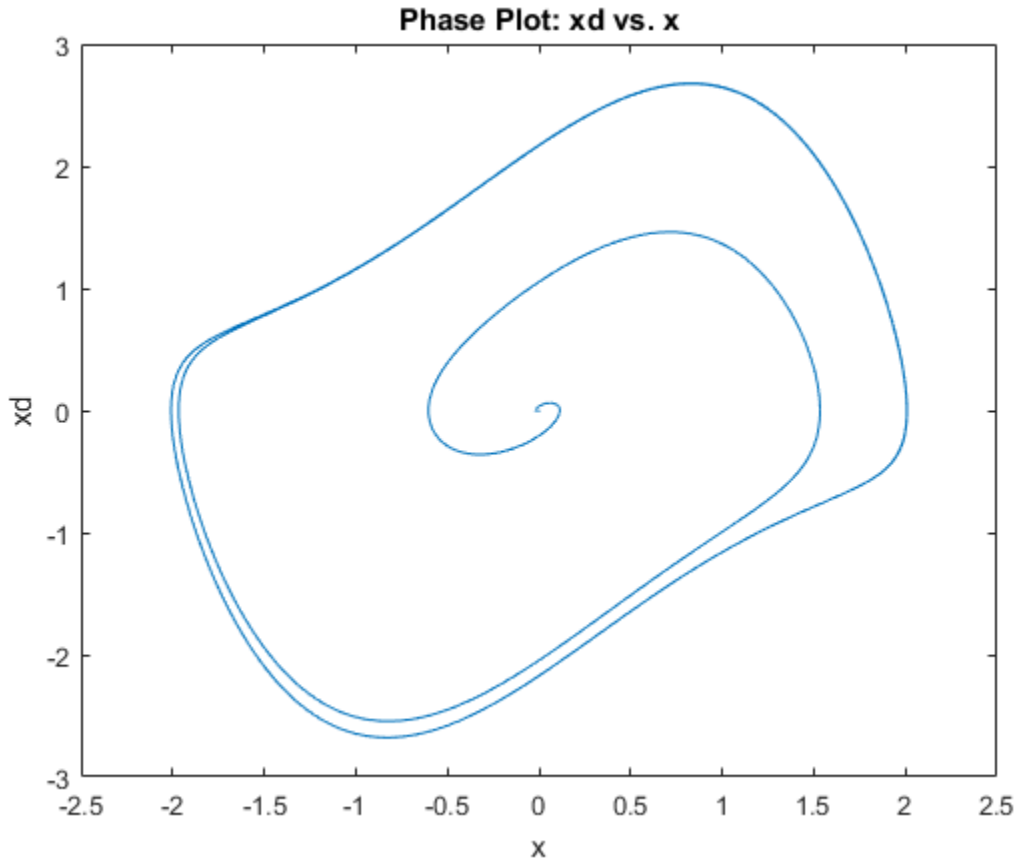

Phase plot showing the limit cycle, from (0,0) startup

Note, the phase space plot shows what is referred to as a limit cycle – a closed trajectory in the phase space where another trajectory spirals into it as time approached infinity.

Next, the random noise input was removed and replaced with the initial condition of $x = 5$:

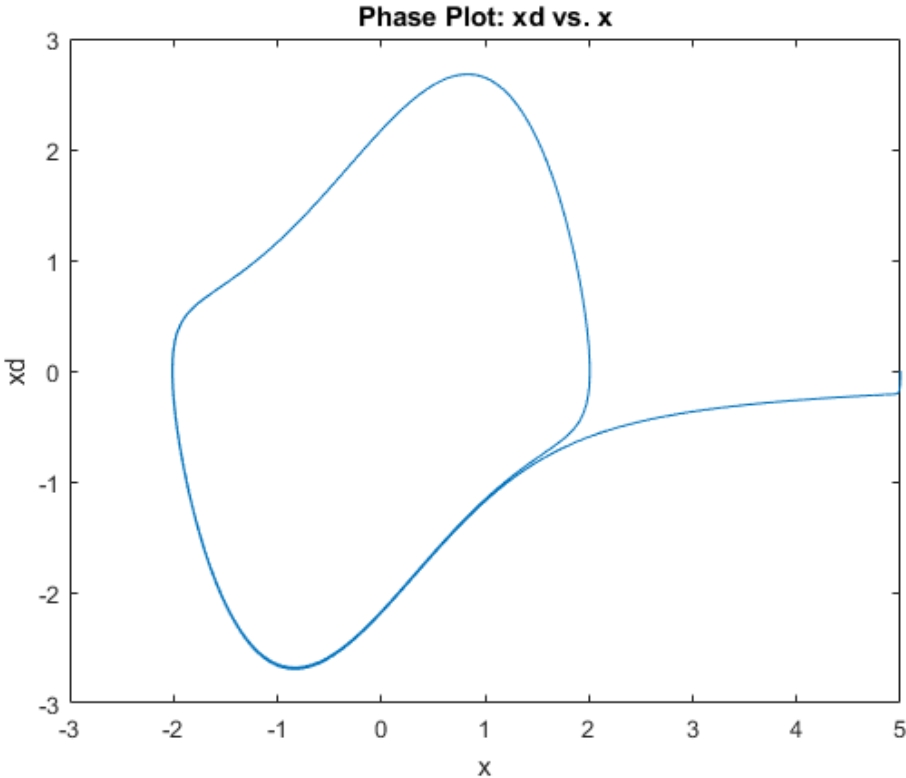
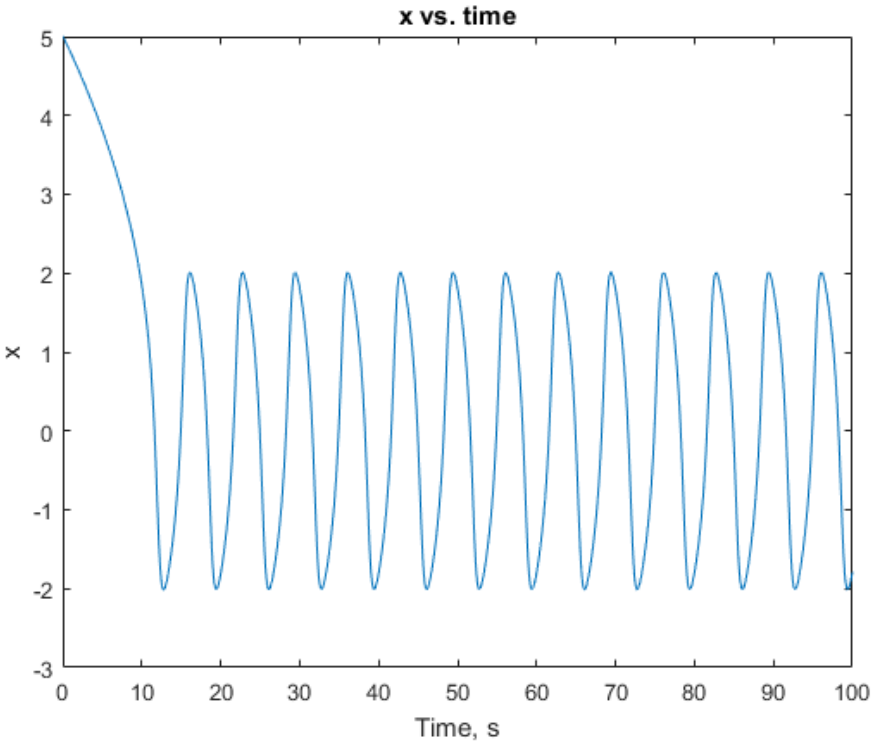

Handout Homework 2

Automatic Gain Control

As previously shown, $\ddot{x} + (x^2 - 1)\dot{x} + x = 0$ is a nonlinear system that produces a limit cycle with a distorted sinusoid for $x(t)$, which is not a very good sinusoidal oscillator. A better gain adjustment would be to adjust the damping to zero as a function of the amplitude of $x(t)$. The subsystem that accomplishes this is called Automatic Gain Control or AGC.

A simple AGC could consist of rectifying $x(t)$ using a diode circuit, then lowpass filtering the rectified signal, then comparing the filtered signal with a desired amplitude, and adjusting the gain using a four quadrant multiplier.

Here is a simplified version of that using Simulink with $\text{abs}(x)$ used as an ideal fullwave rectifier circuit (next page).

A plot of $x(t)$ vs. time is presented. The system is still a complex nonlinear system, but the output ($x(t)$) is a better sinewave than in the previous system. The process of reaching steady state is complex, though. A phase plot of x_d vs. x is presented for x_d and x during the time span of 150 s to 200 s. Observe that this phase plot of x_d vs. x is pretty close to a perfect circle even through there is still sinusoidal fluctuation in the feedback control signal, $\text{filt}(t)$.

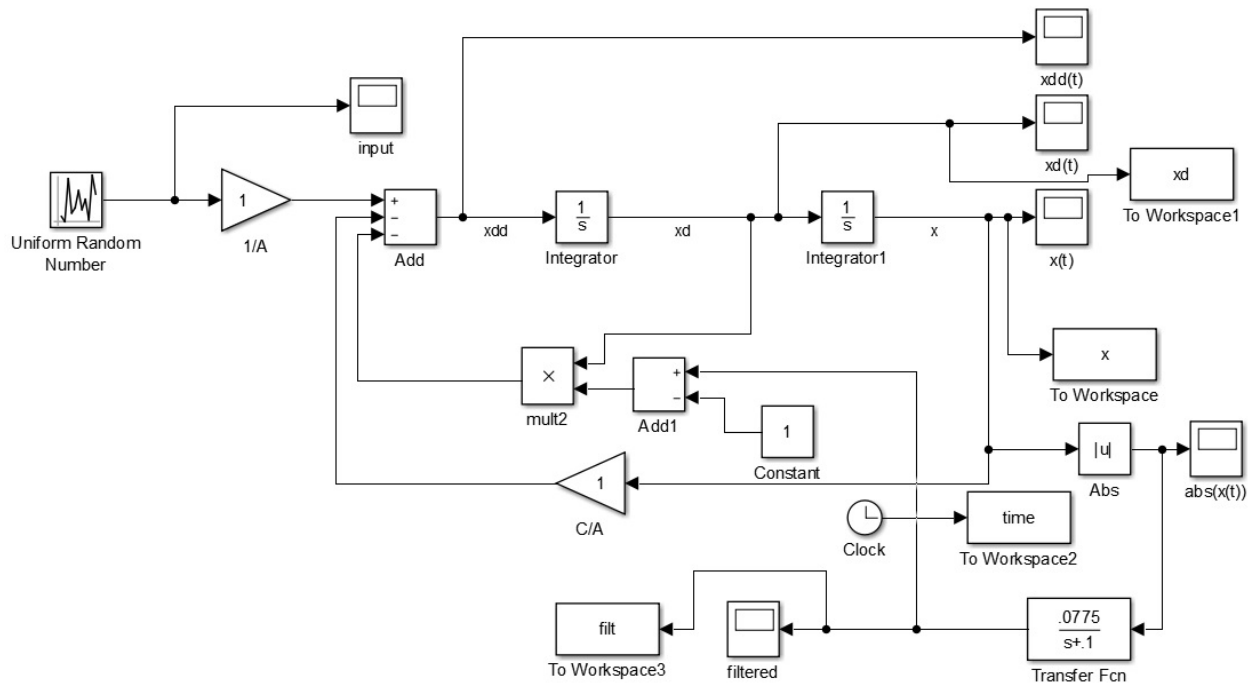

Simulink model

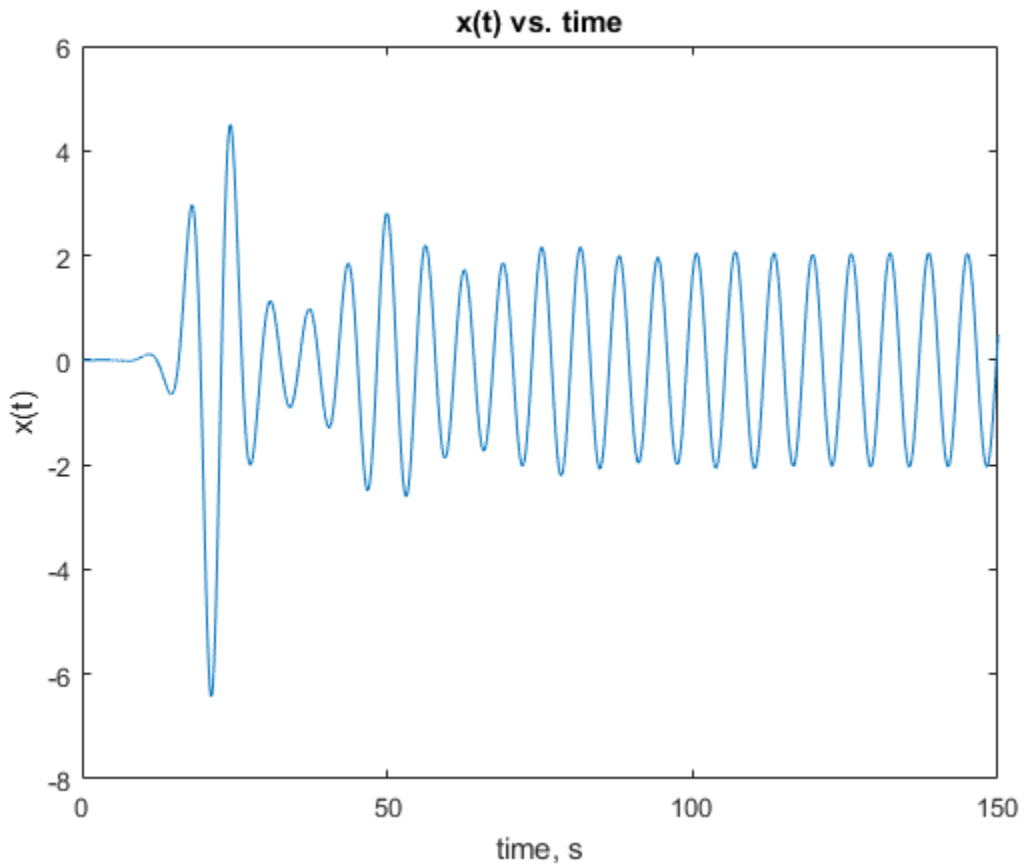

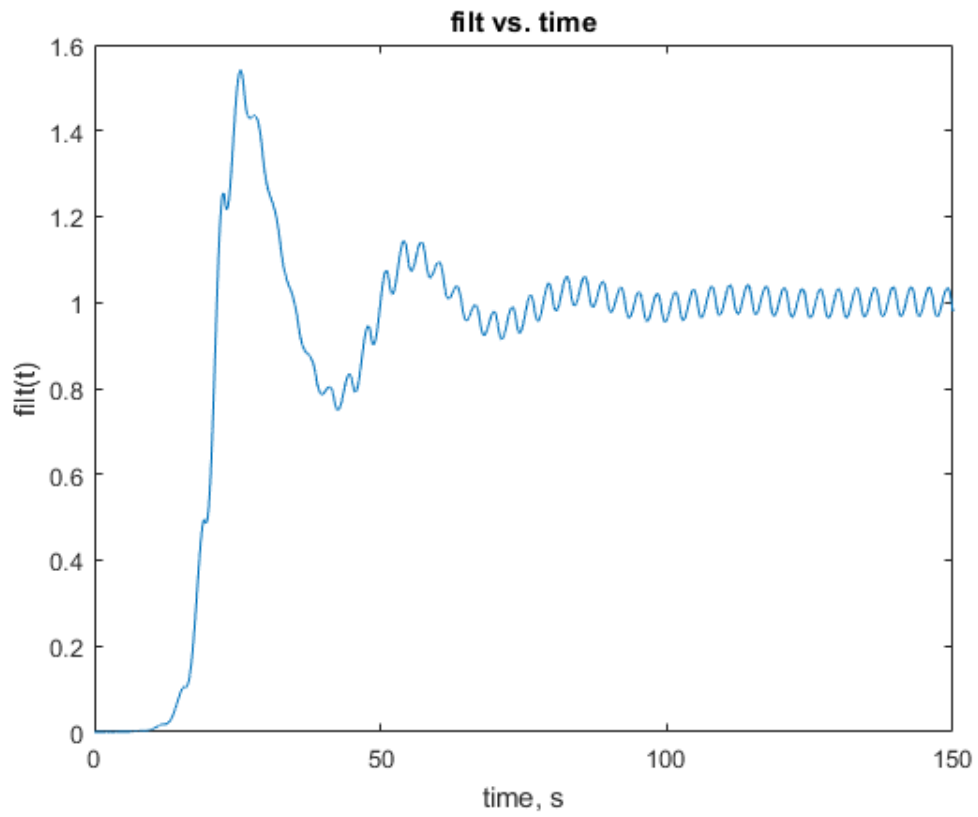
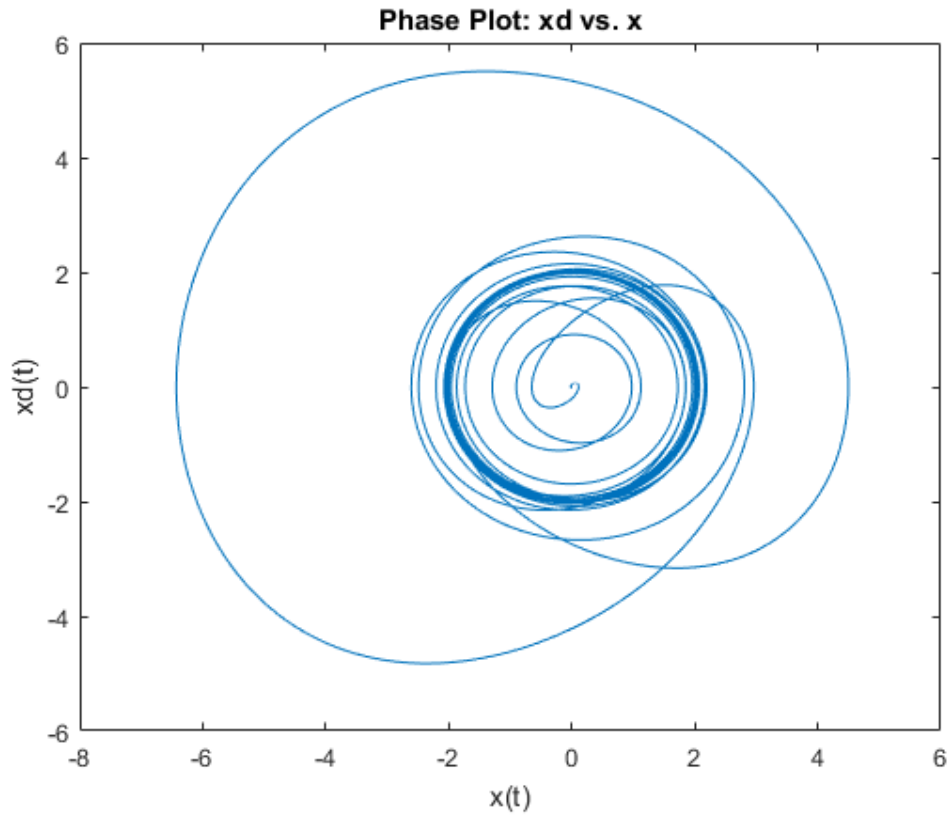

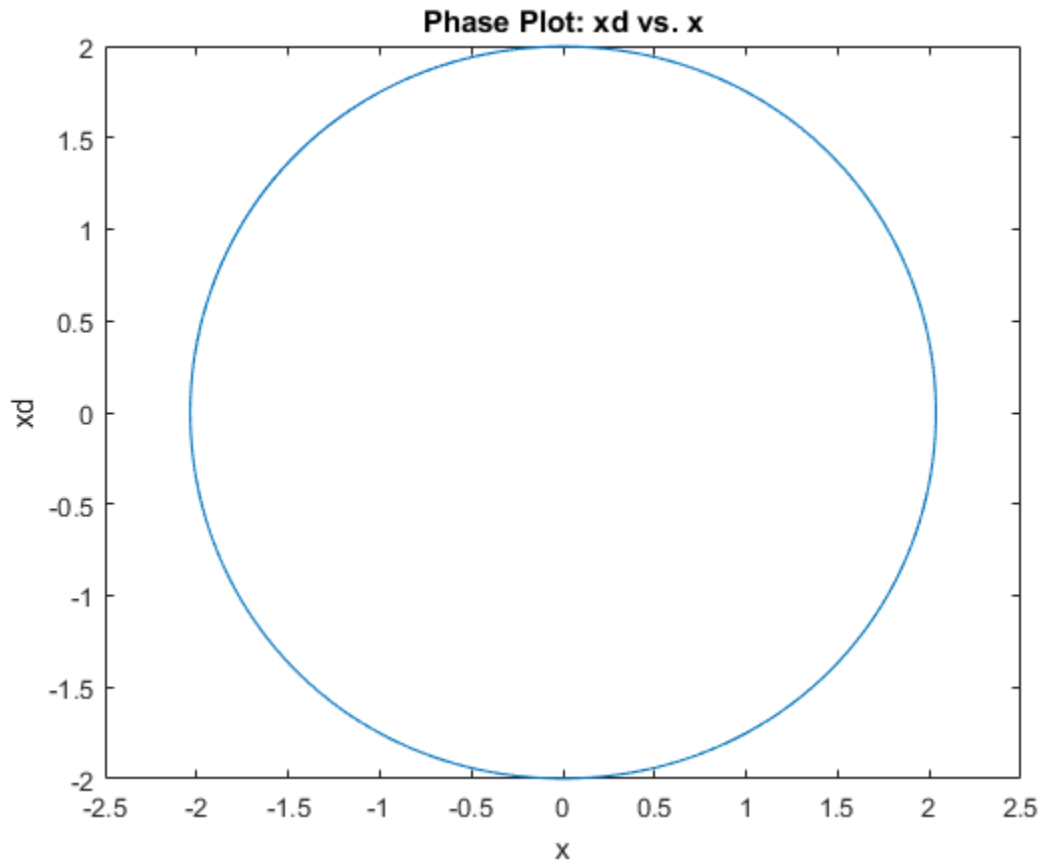

Phase plot of xd vs x for approximately 150s to 200s.

Consider the **Larsen Effect** (Audio Feedback). A block diagram of a PA (Public Address) style audio system is shown below:

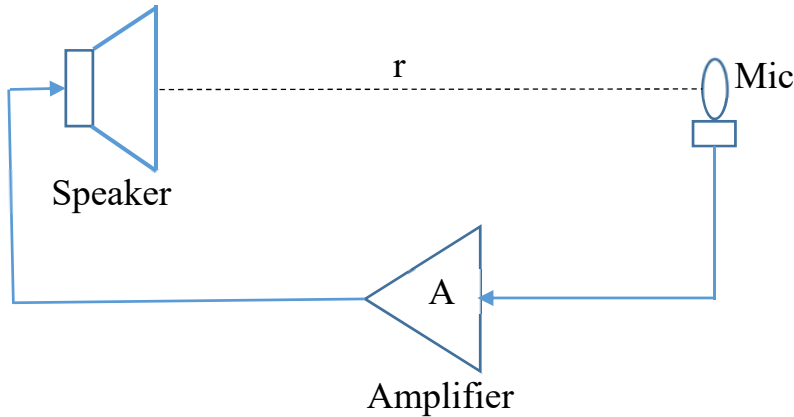

The microphone is basically a pressure sensor. The sound pressure decreases by approximately $1/r$ from the speaker. Sound travels at approximately 343 m/s in air at 20 °C. With an amplifier of sufficient gain in the system, some frequency or frequencies of sound will cause the system to experience negative damping, based upon the electrical characteristics of the system and the distance from the speaker to the mic (total signal phase delay of $n360^\circ$). At that point, the amplitude will grow until the signal experiences clipping in the amplifier. The clipping increases the damping back to zero, satisfying the Barkhausen stability criterion, and results in a loud distorted audio tone.

Except for producing some sounds effects (such as heavy metal guitar sounds), this is usually undesirable and can even damage the equipment in the audio system. Therefore, various techniques have been developed to prevent it from occurring.