

2 Fundamentals: Structural analysis

2.1 Problems

Problem 2.1-2.5

For the planar mechanisms shown in Figs. P2.1-P2.5 determine the mobility table, the structural diagram, the contour diagram, the independent contours, the number of DOF, the dyads, and the type of the dyads.

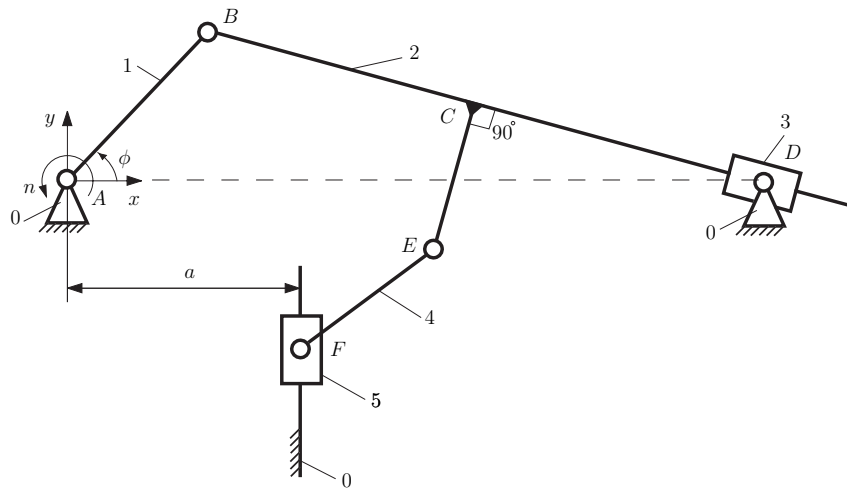

Figure P2.1: Problem P2.1

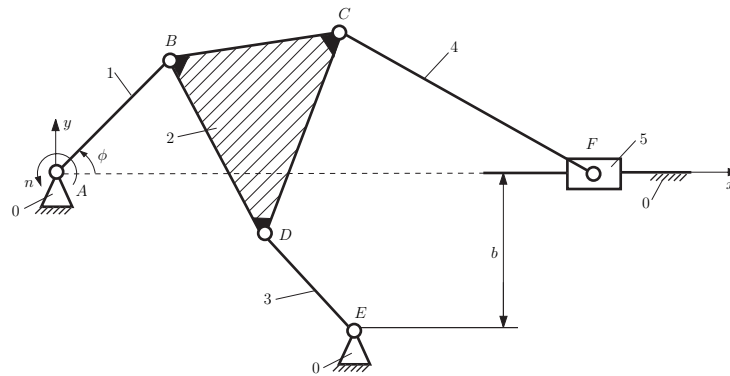

Figure P2.2: Problem P2.2

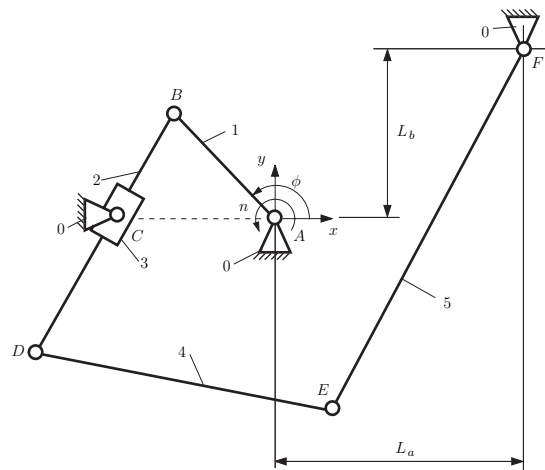

Figure P2.3: Problem P2.3

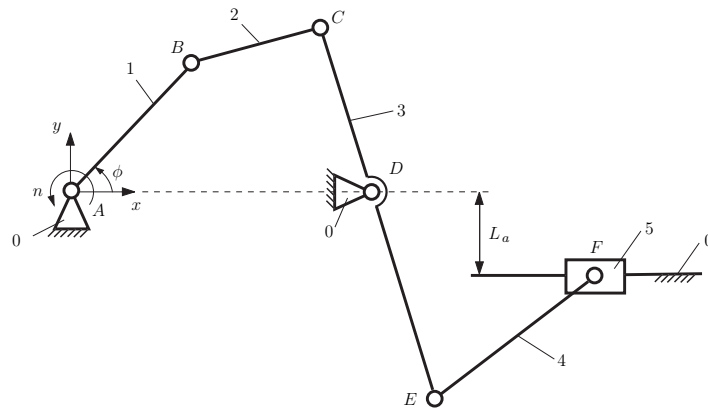

Figure P2.4: Problem P2.4

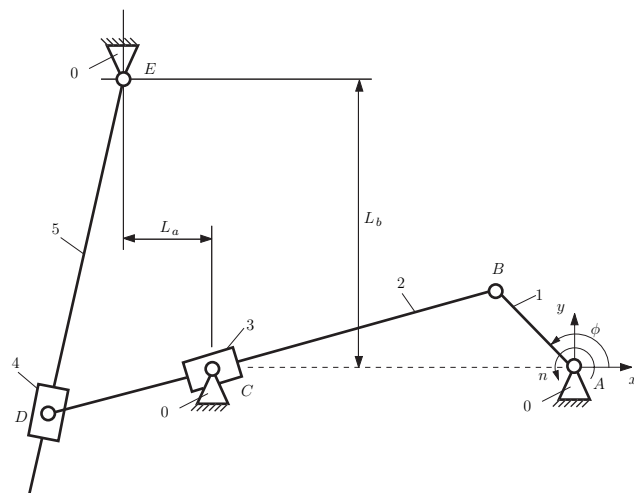

Figure P2.5: Problem P2.5

Problem 2.6

Represent the structural diagram and find the dyads for the mechanism in Fig. P2.6 if the driver is the link AB .

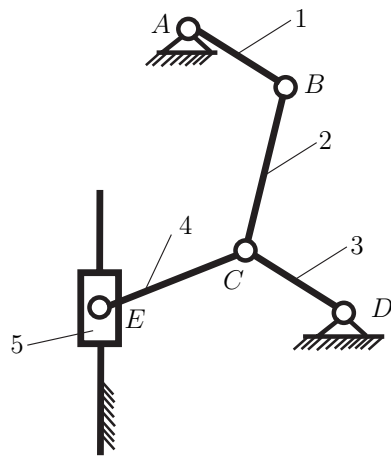

Figure P2.6: Problem P2.6

Problem 2.7

Find the number of degrees of freedom of the mechanism shown in Fig. P2.7.

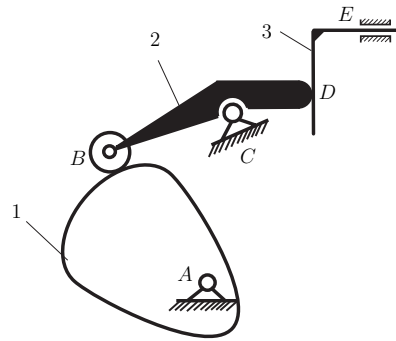

Figure P2.7: Problem P2.7

Problem 2.8 and 2.9

Represent the structural diagrams and find the dyads for the mechanisms in Figs. P2.8 and P2.9 if the driver is link 5.

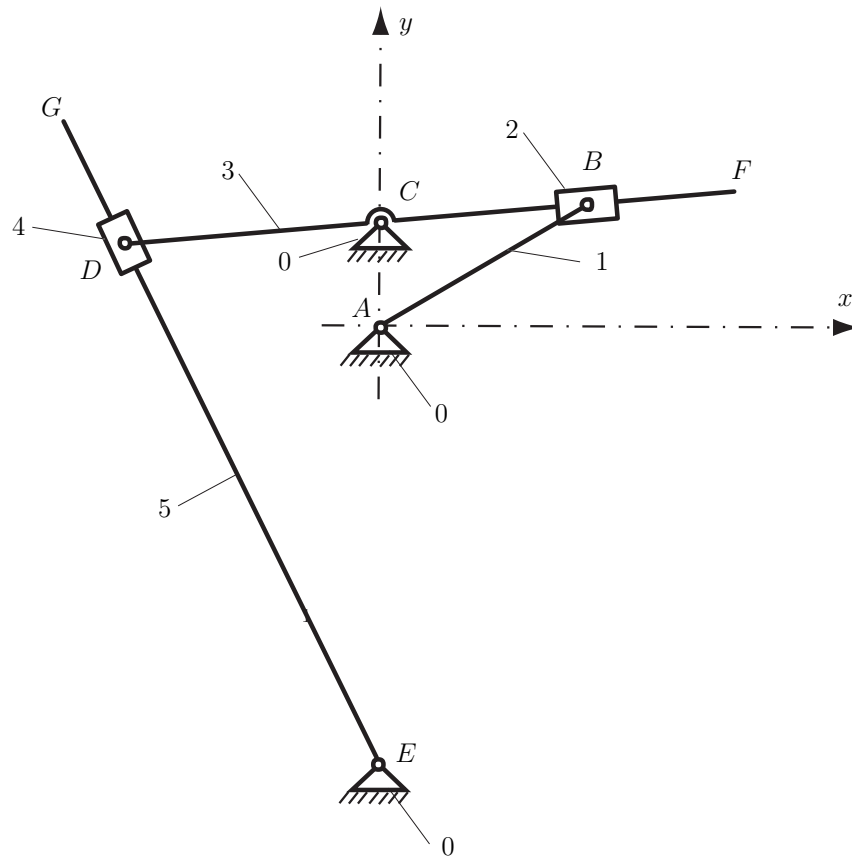

Figure P2.8: Problem P2.8

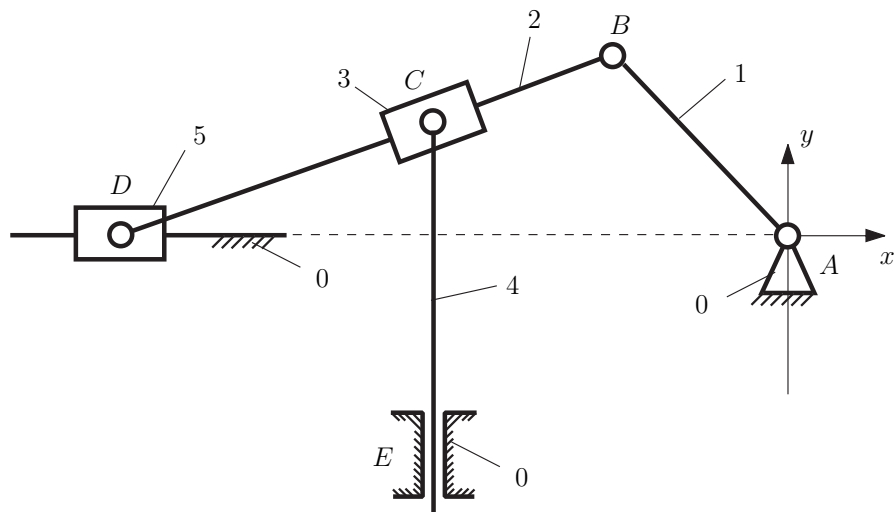

Figure P2.9: Problem P2.9

Problem 2.10

Find the number of degrees of freedom of the mechanism represented in Fig. P2.10.

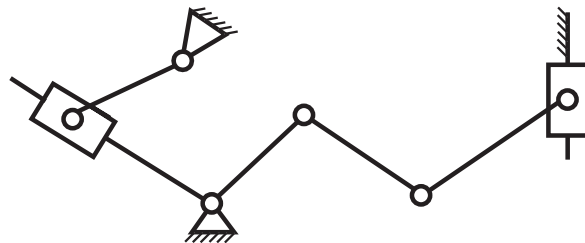

Figure P2.10: Problem P2.10