

1 Direct Dynamics

Newton-Euler Equations of Motion

Problem 22

The planar mechanical system considered is shown in Figure 1.24 and has a slider 1 of mass m_1 and a pendulum 2 with the mass m_2 . The length of AB is L . The local acceleration of gravity is g . The numerical values are: $L = 1$ m, $g = 10$ m/s², and $m_1 = m_2 = 1$ kg. Find the equations of motion of the system.

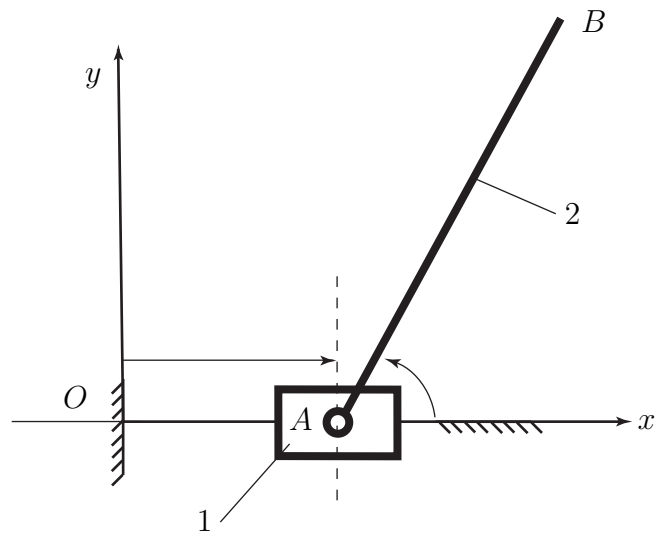

Figure 24