

## I.2 Fundamentals

---

### I.2.1 Degrees of Freedom and Motion

---

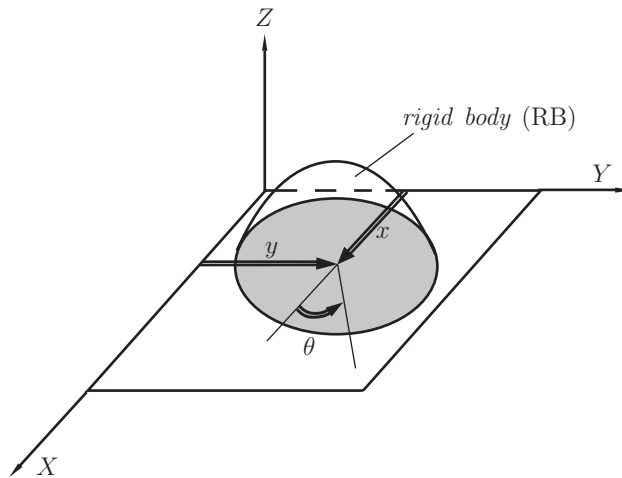
The *number of degrees of freedom* (DOF) of a system is equal to the number of independent parameters (measurements) that are needed to uniquely define its position in space at any instant of time. The number of DOF is defined with respect to a reference frame.

Figure I.2.1 shows a rigid body (RB) lying in a plane. The rigid body is assumed to be incapable of deformation and the distance between two particles on the rigid body is constant at any time. If this rigid body always remains in the plane, three parameters (three DOF) are required to completely define its position: two linear coordinates  $(x, y)$  to define the position of any one point on the rigid body, and one angular coordinate  $\theta$  to define the angle of the body with respect to the axes. The minimum number of measurements needed to define its position are shown in the figure as  $x$ ,  $y$ , and  $\theta$ . A rigid body in a plane then has three degrees of freedom. Note that the particular parameters chosen to define its position are not unique. Any alternative set of three parameters could be used. There is an infinity of sets of parameters possible, but in this case there must always be three parameters per set, such as two lengths and an angle, to define the position because a rigid body in plane motion has three DOF.

Six parameters are needed to define the position of a free rigid body in a three-dimensional (3-D) space. One possible set of parameters which could be used are three lengths,  $(x, y, z)$ , plus three angles  $(\theta_x, \theta_y, \theta_z)$ . Any free rigid body in 3-D space has six degrees of freedom.

A rigid body free to move in a reference frame will, in the general case, have complex motion, which is simultaneously a combination of rotation and translation. For simplicity, only the two-dimensional (2-D) or planar case will be presented. For planar motion the following terms will be defined, Figure I.2.2:

- Pure rotation in which the body possesses one point (center of rotation) which has no motion with respect to a “fixed” reference frame [Fig. I.2.2(a)]. All other points on the body describe arcs about that center.
- Pure translation in which all points on the body describe parallel paths [Fig. I.2.2(b)].



**FIGURE I.2.1** Rigid body in planar motion with three DOF: translation along the  $x$  axis, translation along the  $y$  axis, and rotation,  $\theta$ , about the  $z$ .

- Complex motion that exhibits a simultaneous combination of rotation and translation [Fig. I.2.2(c)]. With general plane motion, points on the body will travel nonparallel paths, and there will be, at every instant, a center of rotation, which will continuously change location.

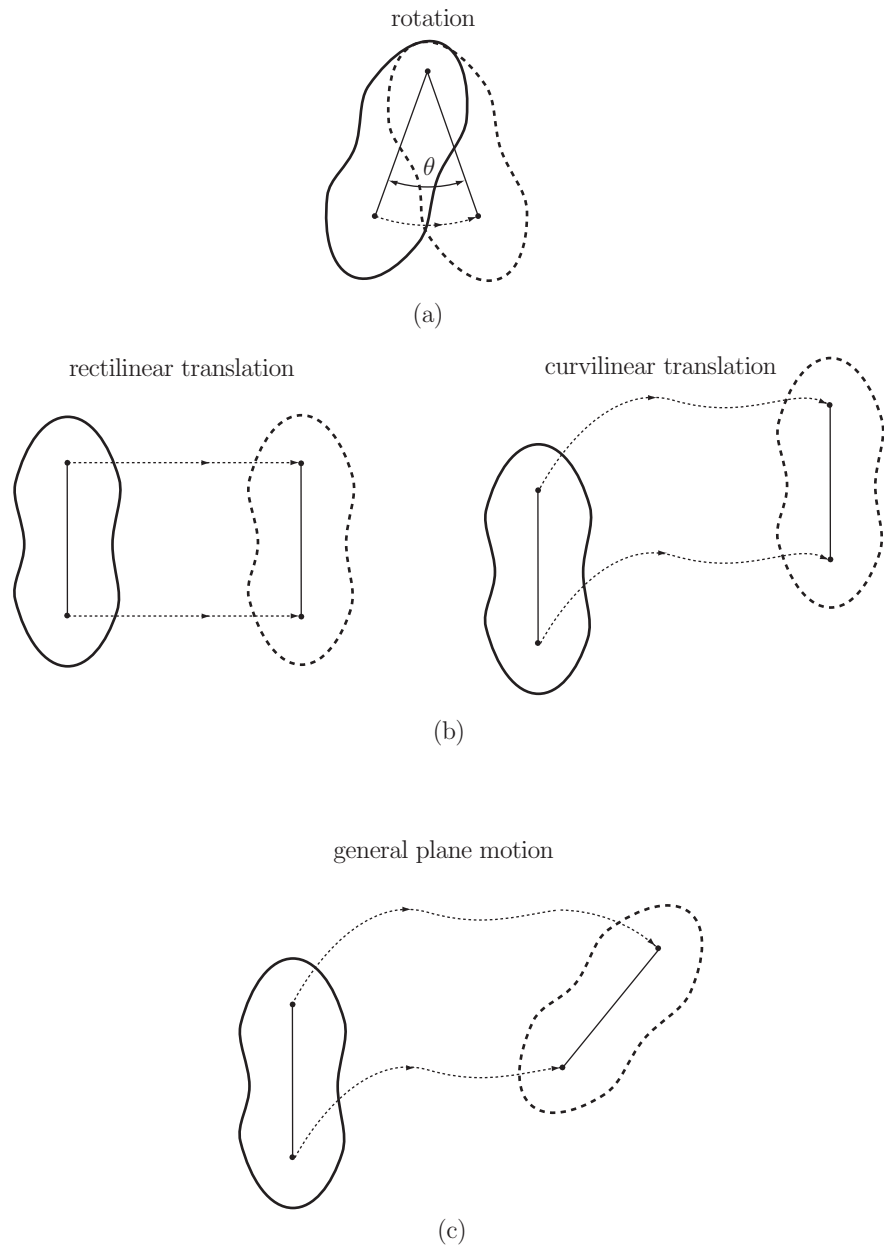
Translation and rotation represent independent motions of the body. Each can exist without the other. For a 2-D coordinate system, as shown in Figure I.2.1, the  $x$  and  $y$  terms represent the translation components of motion, and the  $\theta$  term represents the rotation component.

## I.2.2 Links and Joints

Linkages are basic elements of all mechanisms. Linkages are made up of links and joints. A *link*, sometimes known as an *element* or a *member*, is an (assumed) rigid body which possesses nodes. *Nodes* are defined as points at which links can be attached. A link connected to its neighboring elements by  $s$  nodes is an element of *degree*  $s$ . A link of degree 1 is also called unary [Fig. I.2.3(a)], of degree 2, binary [Fig. I.2.3(b)], and of degree 3, ternary [Fig. I.2.3(c)], etc.

A *joint* is a connection between two or more links (at their nodes). A joint allows some relative motion between the connected links. Joints are also called *kinematic pairs*.

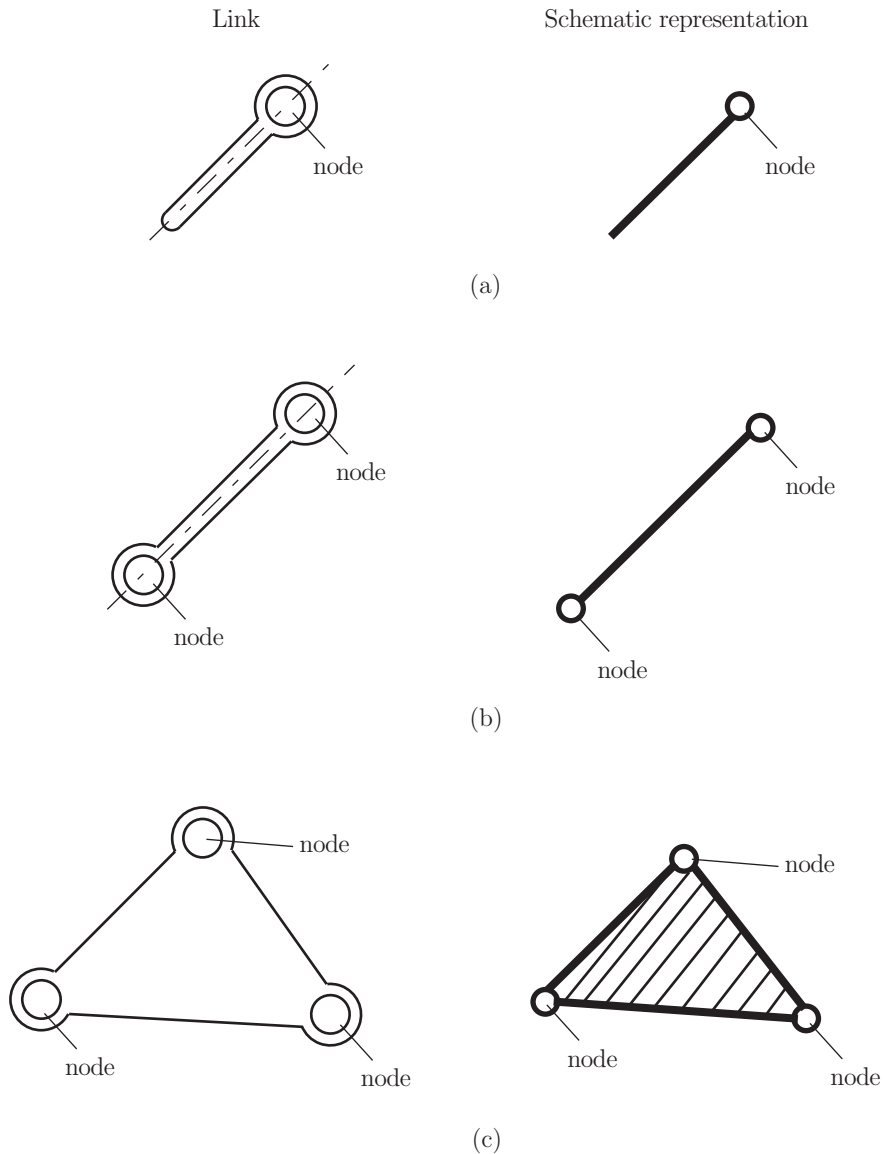
The number of independent coordinates that uniquely determine the relative position of two constrained links is termed *degree of freedom* of a given joint. Alternatively the term *joint class* is introduced. A kinematic pair is of the  $j$ th class if it diminishes the relative motion of linked bodies by  $j$  degrees of freedom; i.e.,  $j$  scalar constraint conditions correspond to the given kinematic pair. It follows that such a joint has  $(6 - j)$  independent coordinates. The number of DOF is the fundamental characteristic quantity of joints. One of the links of a system is usually considered to be the reference link, and the position of other RBs is



**FIGURE I.2.2** Rigid body in motion: (a) pure rotation, (b) pure translation, and (c) general motion.

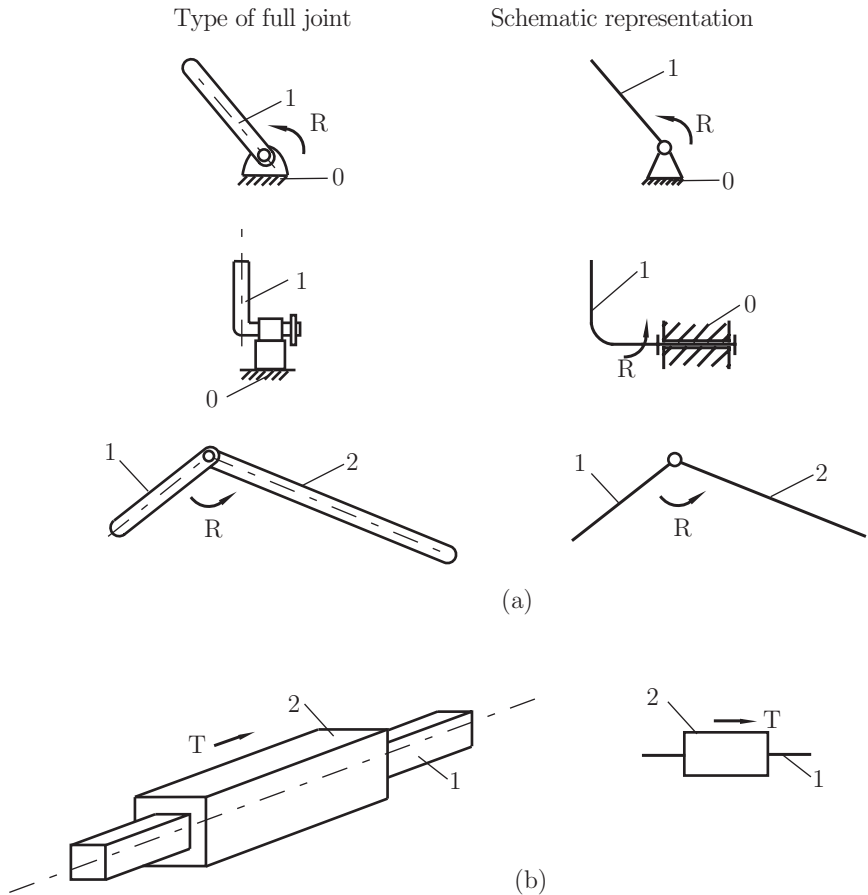
determined in relation to this reference body. If the reference link is stationary, the term *frame* or *ground* is used.

The coordinates in the definition of DOF can be linear or angular. Also the coordinates used can be absolute (measured with regard to the frame) or relative. Figures I.2.4–I.2.9



**FIGURE I.2.3** Types of links: (a) unary, (b) binary, and (c) ternary elements.

show examples of joints commonly found in mechanisms. Figures I.2.4(a) and I.2.4(b) show two forms of a planar, one DOF joint, namely a rotating pin joint and a translating slider joint. These are both typically referred to as *full joints* and are of the 5th class. The pin joint allows one rotational (R) DOF, and the slider joint allows one translational (T) DOF between the joined links. These are both special cases of another common, one DOF joint, the screw and nut [Fig. I.2.5(a)]. Motion of either the nut or the screw relative to the other results in helical motion. If the helix angle is made zero [Fig. I.2.5(b)], the nut rotates



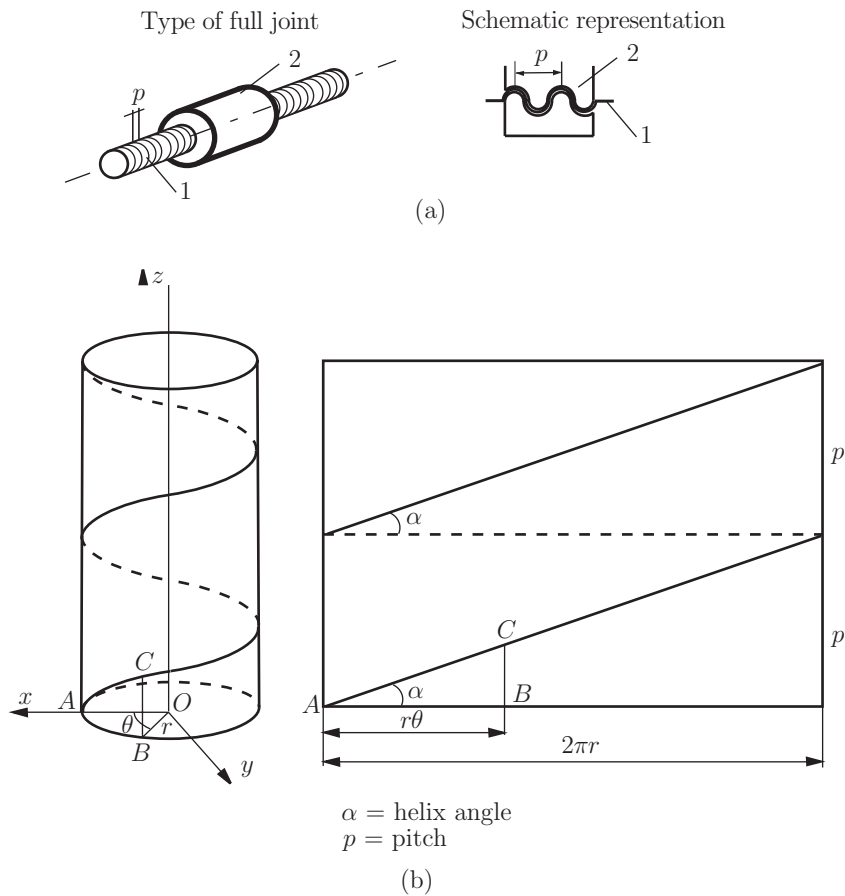
**FIGURE I.2.4** One DOF joint, full joint (5th class): (a) pin joint, and (b) slider joint.

without advancing and it becomes a pin joint. If the helix angle is made  $90^\circ$ , the nut will translate along the axis of the screw, and it becomes a slider joint.

Figure I.2.6 shows examples of two DOF joints, which simultaneously allow two independent, relative motions, namely translation (T) and rotation (R), between the joined links. A two DOF joint is usually referred to as a *half joint* and is of the 4th class. A half joint is sometimes also called a roll-slide joint because it allows both rotation (rolling) and translation (sliding).

A joystick, ball-and-socket joint, or sphere joint [Fig. I.2.7(a)], is an example of a three DOF joint (3rd class), which allows three independent angular motions between the two links that are joined. This ball joint would typically be used in a 3-D mechanism, one example being the ball joints used in automotive suspension systems. A plane joint [Fig. I.2.7(b)] is also an example of a three DOF joint, which allows two translations and one rotation.

Note that to visualize the DOF of a joint in a mechanism, it is helpful to “mentally disconnect” the two links that create the joint from the rest of the mechanism. It is easier to see how many DOF the two joined links have with respect to one another. Figure I.2.8



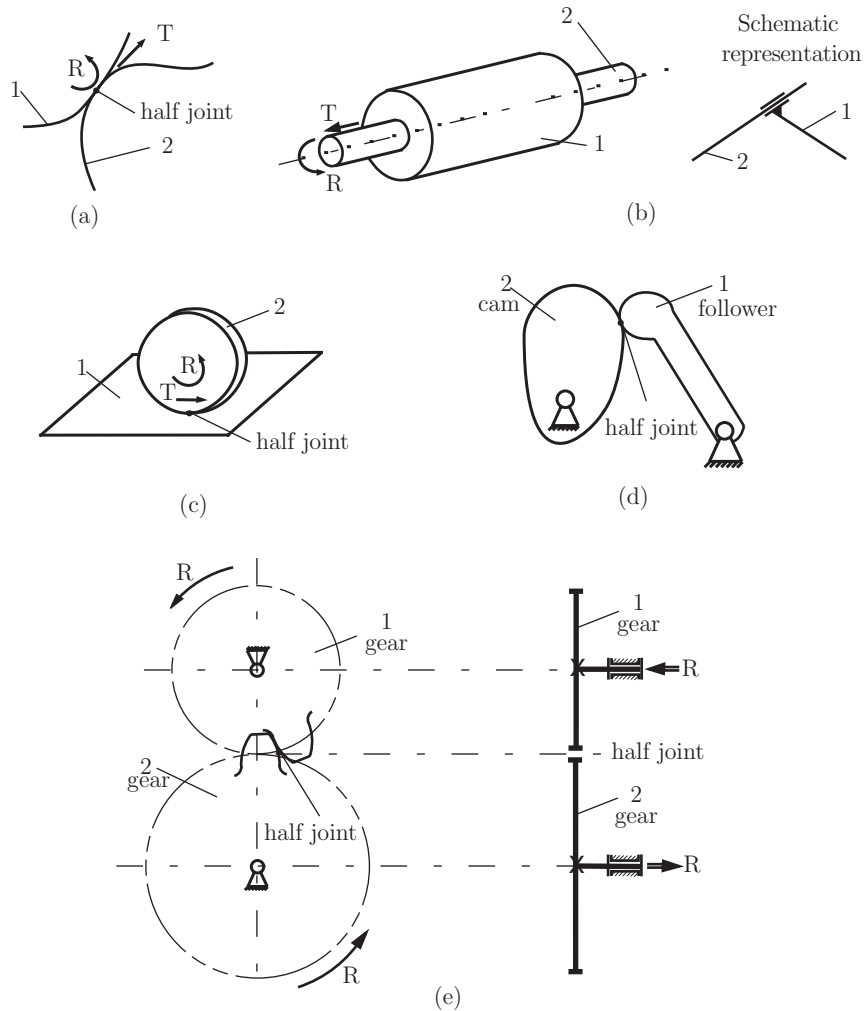
**FIGURE I.2.5** (a) Screw and nut joint; (b) helical motion.

shows an example of a 2nd class joint (cylinder on plane) and Figure I.2.9 represents a 1st class joint (sphere on plane).

The type of contact between the elements can be point (P), curve (C), or surface (S). The term *lower joint* was coined by Reuleaux to describe joints with surface contact. He used the term *higher joint* to describe joints with point or curve contact. The main practical advantage of lower joints over higher joints is their ability to better trap lubricant between their enveloping surfaces. This is especially true for the rotating pin joint.

A *closed joint* is a joint that is kept together or closed by its geometry. A pin in a hole or a slider in a two-sided slot are forms of closed joints. A *force closed joint*, such as a pin in a half-bearing or a slider on a surface, requires some external force to keep it together or closed. This force could be supplied by gravity, by a spring, or by some external means. In linkages, closed joints are usually preferred, and are easy to accomplish. For cam-follower systems force closure is often preferred.

The *order of a joint* is defined as the number of links joined minus one. The simplest joint combination of two links has order one and it is a single joint [Fig. I.2.10(a)]. As additional

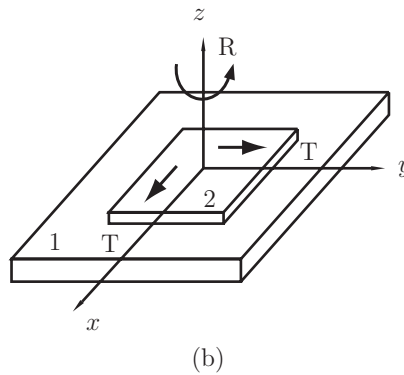
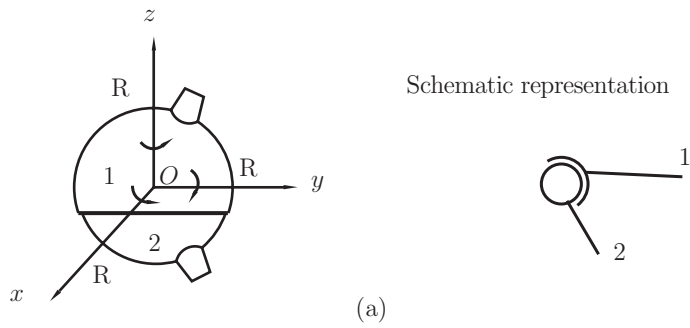


**FIGURE I.2.6** Two DOF joint, half joint (4th class): (a) general joint, (b) cylinder joint, (c) roll and slide disk, (d) cam-follower joint, and (e) gear joint.

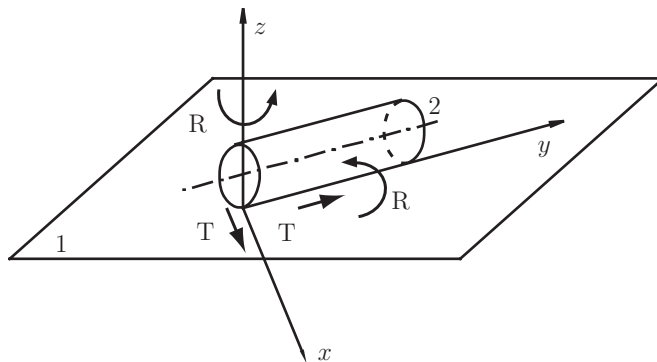
links are placed on the same joint, the order is increased on a one for one basis [Fig. I.2.10(b)]. Joint order has significance in the proper determination of overall DOF for an assembly.

Bodies linked by joints form a *kinematic chain*. Simple kinematic chains are shown in Figure I.2.11. A *contour* or *loop* is a configuration described by a polygon consisting of links connected by joints [Fig. I.2.11(a)]. The presence of loops in a mechanical structure can be used to define the following types of chains:

- *Closed kinematic chains* have one or more loops so that each link and each joint is contained in at least one of the loops [Fig. I.2.11(a)]. A closed kinematic chain has no open attachment point.

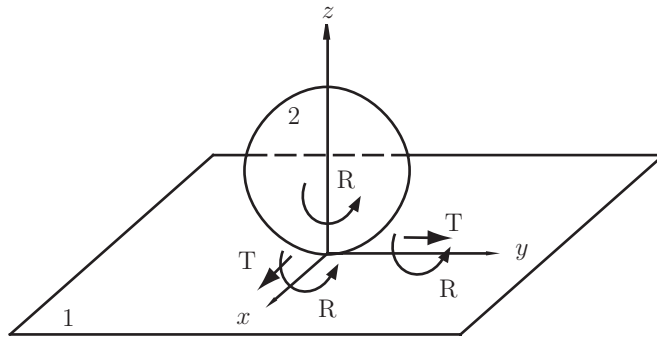


**FIGURE I.2.7** Three DOF joint (3rd class): (a) ball and socket joint, and (b) plane joint.

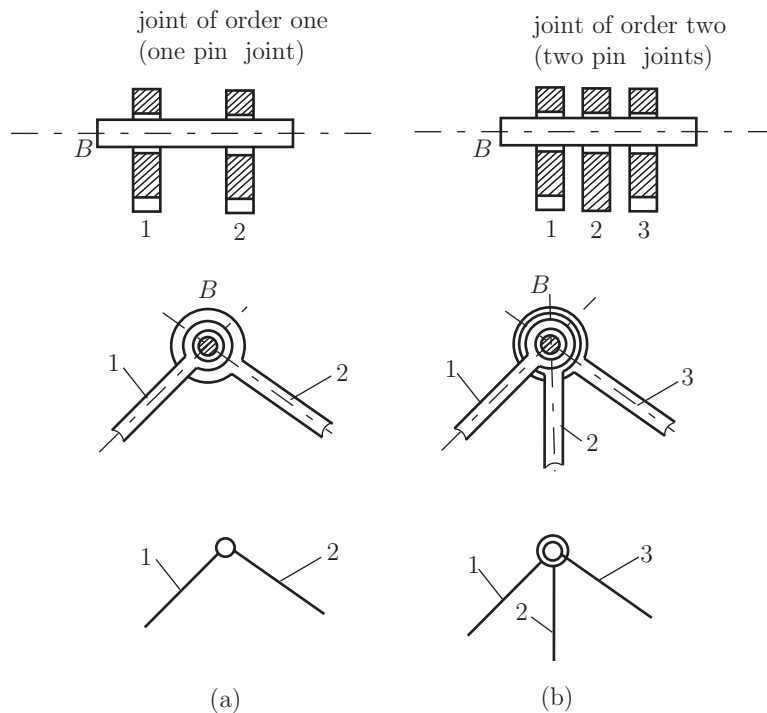


**FIGURE I.2.8** Four DOF joint (2nd class) cylinder on a plane.

- *Open kinematic chains* contain no closed loops [Fig. I.2.11(b)]. A common example of an open kinematic chain is an industrial robot.
- *Mixed kinematic chains* are a combination of closed and open kinematic chains.



**FIGURE I.2.9** Five DOF joint (1st class) sphere on a plane.



**FIGURE I.2.10** Order of a joint: (a) joint of order one, and (b) joint of order two (multiple joints).

Another classification is also useful:

- *Simple chains* contain only binary elements.
- *Complex chains* contain at least one element of degree 3 or higher.

A *mechanism* is defined as a kinematic chain in which at least one link has been “grounded” or attached to the frame [Figs. I.2.11(a) and I.2.12]. Using Reuleaux’s definition,

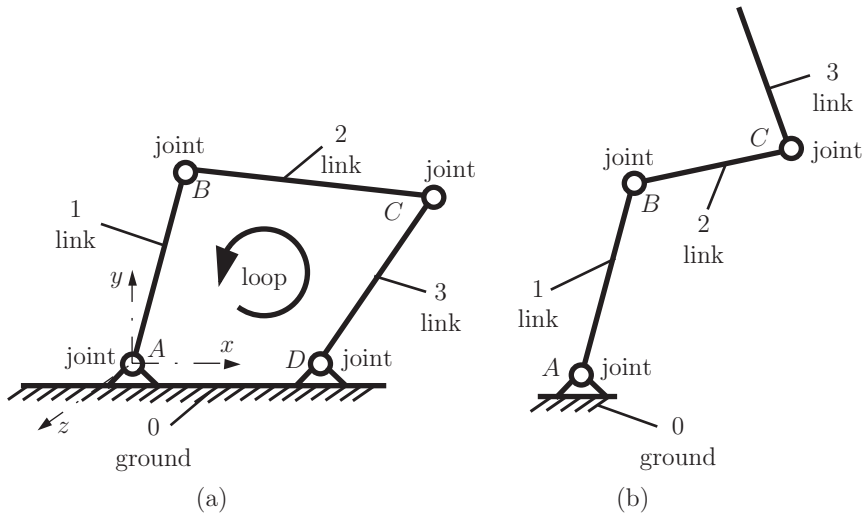


FIGURE I.2.11 Kinematic chains: (a) closed kinematic chain, and (b) open kinematic chain.

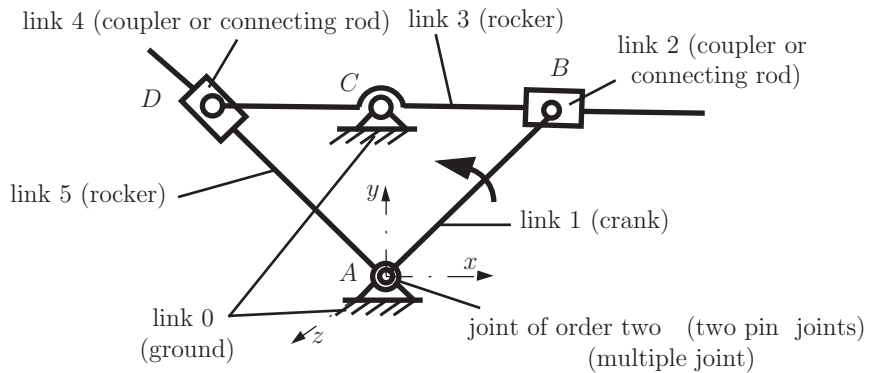


FIGURE I.2.12 Complex mechanism with five moving links.

a *machine* is a collection of mechanisms arranged to transmit forces and do work. He viewed all energy, or force-transmitting devices as machines that utilize mechanisms as their building blocks to provide the necessary motion constraints.

The following terms can be defined (Fig. I.2.12):

- A *crank* is a link that makes a complete revolution about a fixed grounded pivot.
- A *rocker* is a link that has oscillatory (back and forth) rotation and is fixed to a grounded pivot.
- A *coupler* or connecting rod is a link that has complex motion and is not fixed to ground.

*Ground* is defined as any link or links that are fixed (nonmoving) with respect to the reference frame. Note that the reference frame may in fact itself be in motion.

## I.2.3 Family and Degrees of Freedom

The concept of *number of degrees of freedom* is fundamental to the analysis of mechanisms. It is usually necessary to be able to determine quickly the number of DOF of any collection of links and joints that may be used to solve a problem.

The number of DOF or the *mobility* of a system can be defined as:

- the number of inputs that need to be provided in order to create a predictable system output, or
- the number of independent coordinates required to define the position of the system.

The *family*  $f$  of a mechanism is the number of DOF that are eliminated from all the links of the system. Every free body in space has six degrees of freedom. A system of family  $f$  consisting of  $n$  movable links has  $(6 - f)n$  degrees of freedom. Each joint of class  $j$  diminishes the freedom of motion of the system by  $j - f$  degrees of freedom. Designating the number of joints of class  $k$  as  $c_k$ , it follows that the number of degrees of freedom of the particular system is

$$M = (6 - f)n - \sum_{j=f+1}^5 (j - f)c_j. \quad (I.2.1)$$

This is referred to in the literature on mechanisms as the Dobrovolski formula.

A *driver* link is that part of a mechanism that causes motion. An example is a crank. The number of driver links is equal to the number of DOF of the mechanism. A *driven* link or *follower* is that part of a mechanism whose motion is affected by the motion of the driver.

### Mechanisms of family $f = 1$

The family of a mechanism can be computed with the help of a mobility table (Table I.2.1). Consider the mechanism, shown in Figure I.2.13, that can be used to measure the weight of postal envelopes. The translation along the  $i$ -axis is denoted by  $T_i$ , and the rotation about the  $i$ -axis is denoted by  $R_i$ , where  $i = x, y, z$ . Every link in the mechanism is analyzed in terms of its translation and rotation about the reference frame  $xyz$ . For example the link 0 (ground) has no translations,  $T_i = \text{No}$ , and no rotations,  $R_i = \text{No}$ . The link 1 has a rotation

**TABLE I.2.1** Mobility Table for the Mechanism Shown in Figure I.2.13

| Link | $T_x$ | $T_y$ | $T_z$ | $R_x$ | $R_y$ | $R_z$ |
|------|-------|-------|-------|-------|-------|-------|
| 0    | No    | No    | No    | No    | No    | No    |
| 1    | No    | No    | No    | No    | No    | Yes   |
| 2    | Yes   | Yes   | No    | No    | No    | Yes   |
| 3    | No    | Yes   | No    | No    | No    | No    |
| 4    | No    | Yes   | Yes   | Yes   | No    | No    |
| 5    | No    | No    | No    | Yes   | No    | No    |
| No   |       |       |       |       |       |       |

For all links  $R_y = \text{No} \implies f = 1$ .

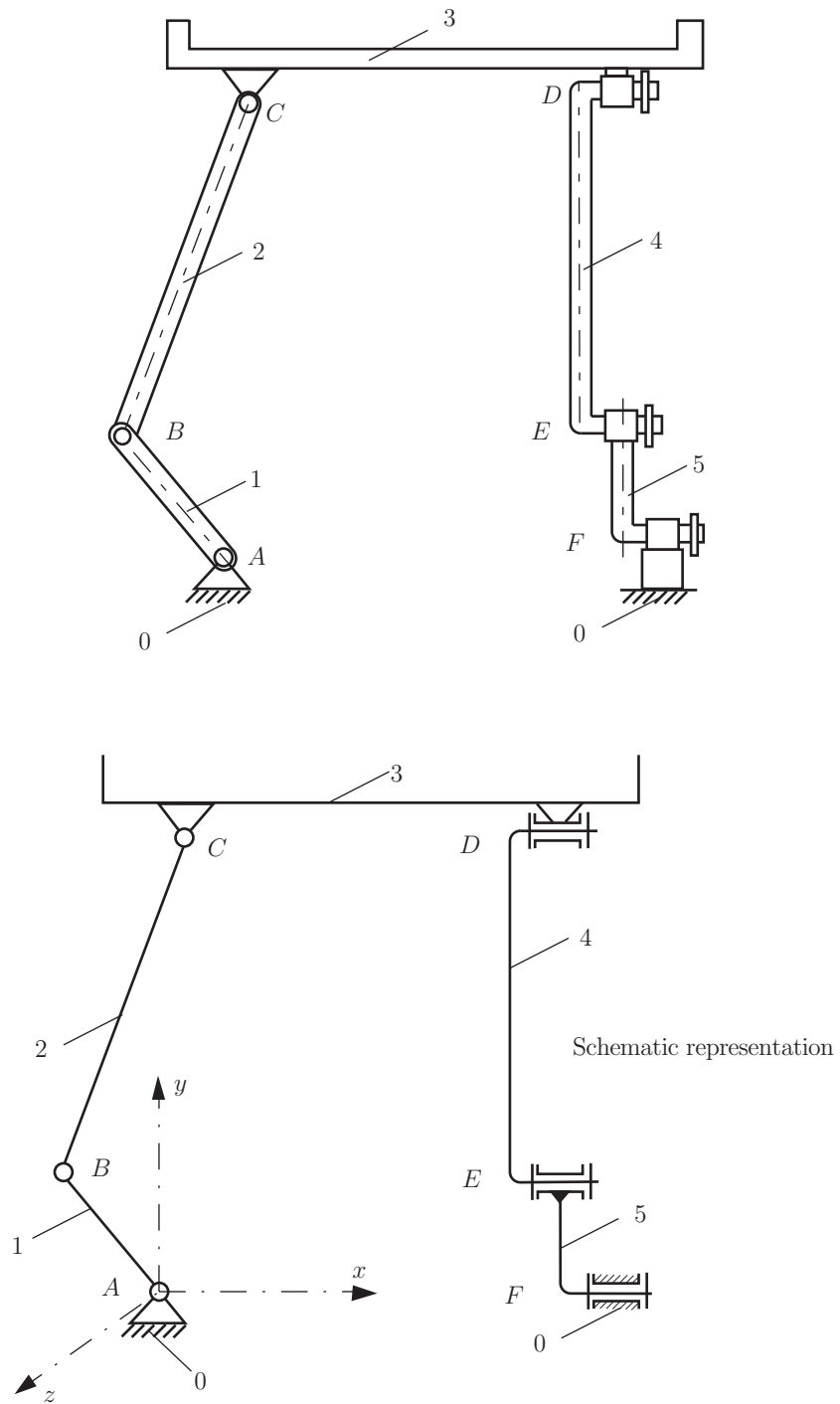


FIGURE I.2.13 *Spatial mechanism of family  $f = 1$ .*

motion about the  $z$ -axis,  $R_z = \text{Yes}$ . The link 2 has a planar motion ( $xy$  is the plane of motion) with a translation along the  $x$ -axis,  $T_x = \text{Yes}$ , a translation along the  $y$ -axis,  $T_y = \text{Yes}$ , and a rotation about the  $z$ -axis,  $R_z = \text{Yes}$ . The link 3 has a translation along  $y$ ,  $T_y = \text{Yes}$ . The link 4 has a planar motion ( $yz$ , the plane of motion) with a translation along  $y$ ,  $T_y = \text{Yes}$ , a translation along  $z$ ,  $T_z = \text{Yes}$ , and a rotation about  $x$ ,  $R_x = \text{Yes}$ . The link 5 has a rotation about the  $x$ -axis,  $R_x = \text{Yes}$ . The results of this analysis are presented with the help of a mobility table (Table I.2.1).

From Table I.2.1 it can be seen that link  $i$ ,  $i = 0, 1, 2, 3, 4, 5$ , has no rotation about the  $y$ -axis, i.e., there is no rotation about the  $y$ -axis for any of the links of the mechanism ( $R_y = \text{No}$ ). The family of the mechanism is  $f = 1$  because there is one DOF, rotation about  $y$ , which is eliminated from all the links.

There are six joints of class 5 (rotational joints) in the system at  $A, B, C, D, E$ , and  $F$ . The number of DOF for the mechanism in Figure I.2.13, which is of  $f = 1$  family is given by

$$M = 5n - \sum_{j=2}^5 (j-1)c_j = 5n - 4c_5 - 3c_4 - 2c_3 - c_2 = 5(5) - 4(6) = 1.$$

The mechanism has one DOF (one driver link).

## Mechanisms of family $f = 2$

A mobility table for a mechanism of family  $f = 2$  (Fig. I.2.14) is given in Table I.2.2.

The number of DOF for the  $f = 2$  family mechanism is given by

$$M = 4n - \sum_{j=3}^5 (j-2)c_j = 4n - 3c_5 - 2c_4 - c_3.$$

The mechanism in Figure I.2.14 has four moving links ( $n = 4$ ), four rotational joints ( $A, B, D, E$ ) and one screw and nut joint ( $C$ ); i.e., there are five joints of class 5 ( $c_5 = 5$ ). The number of DOF for this mechanism is

$$M = 4n - 3c_5 - 2c_4 - c_3 = 4(4) - 3(5) = 1.$$

**TABLE I.2.2** Mobility Table for the Mechanism Shown in Figure I.2.14

| Link | $T_x$ | $T_y$ | $T_z$ | $R_x$ | $R_y$ | $R_z$ |
|------|-------|-------|-------|-------|-------|-------|
| 0    | No    | No    | No    | No    | No    | No    |
| 1    | No    | No    | No    | No    | No    | Yes   |
| 2    | Yes   | Yes   | No    | Yes   | No    | Yes   |
| 3    | Yes   | Yes   | No    | No    | No    | Yes   |
| 4    | No    | No    | No    | No    | No    | Yes   |
|      |       |       | No    |       | No    |       |

For all links  $T_z = \text{No}$  &  $R_y = \text{No} \implies f = 2$ .

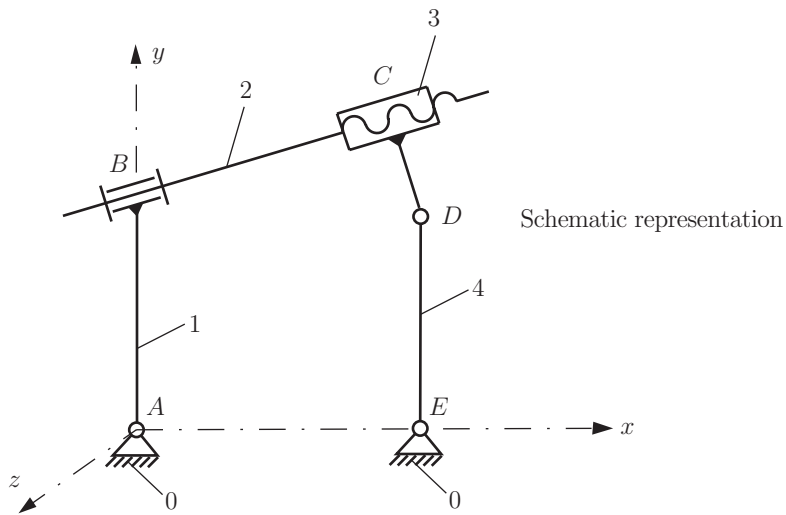
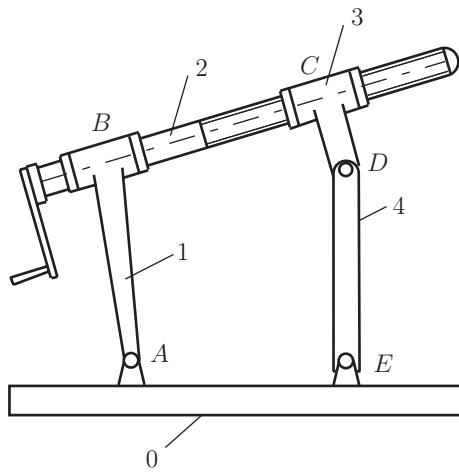


FIGURE I.2.14 Spatial mechanism of family  $f = 2$ .

### Mechanisms of family $f = 3$

The number of DOF for mechanisms of family  $f = 3$  is given by

$$M = 3n - \sum_{j=4}^5 (j-3)c_j = 3n - 2c_5 - c_4.$$

For the mechanism in Figure I.2.11(a) the mobility table is given in Table I.2.3.

**TABLE I.2.3** Mobility Table for the Mechanism Shown in Figure I.2.11(a)

| <i>Link</i> | $T_x$ | $T_y$ | $T_z$ | $R_x$ | $R_y$ | $R_z$ |
|-------------|-------|-------|-------|-------|-------|-------|
| 0           | No    | No    | No    | No    | No    | No    |
| 1           | No    | No    | No    | No    | No    | Yes   |
| 2           | Yes   | Yes   | No    | No    | No    | Yes   |
| 3           | No    | No    | No    | No    | No    | Yes   |
|             |       |       | No    | No    | No    |       |

For all links  $T_z = \text{No}$  &  $R_x = \text{No}$  &  $R_y = \text{No} \implies f = 3$ .

**TABLE I.2.4** Mobility Table for the Mechanism Shown in Figure I.2.12

| <i>Link</i> | $T_x$ | $T_y$ | $T_z$ | $R_x$ | $R_y$ | $R_z$ |
|-------------|-------|-------|-------|-------|-------|-------|
| 0           | No    | No    | No    | No    | No    | No    |
| 1           | No    | No    | No    | No    | No    | Yes   |
| 2           | Yes   | Yes   | No    | No    | No    | Yes   |
| 3           | No    | No    | No    | No    | No    | Yes   |
| 4           | Yes   | Yes   | No    | No    | No    | Yes   |
| 5           | No    | No    | No    | No    | No    | Yes   |
|             |       |       | No    | No    | No    |       |

For all links  $T_z = \text{No}$  &  $R_x = \text{No}$  &  $R_y = \text{No} \implies f = 3$ .

The mechanism in Figure I.2.11(a) has three moving links ( $n = 3$ ) and four rotational joints at  $A, B, C$ , and  $D$ , ( $c_5 = 4$ ). The number of DOF for this mechanism is given by

$$M = 3n - 2c_5 - c_4 = 3(3) - 2(4) = 1.$$

The mobility table for the mechanism shown in Figure I.2.12 is given in Table I.2.4.

There are seven joints of class 5 ( $c_5 = 7$ ) in the system:

- at  $A$  there is one rotational joint between link 0 and link 1;
- at  $B$  there is one rotational joint between link 1 and link 2;
- at  $B$  there is one translational joint between link 2 and link 3;
- at  $C$  there is one rotational joint between link 0 and link 3;
- at  $D$  there is one rotational joint between link 3 and link 4;
- at  $D$  there is one translational joint between link 4 and link 5;
- at  $A$  there is one rotational joint between link 5 and link 0.

The number of moving links is five ( $n = 5$ ). The number of DOF for this mechanism is given by

$$M = 3n - 2c_5 - c_4 = 3(5) - 2(7) = 1,$$

and this mechanism has one driver link.

## Mechanisms of family $f = 4$

The number of DOF for mechanisms of family  $f = 4$  is given by

$$M = 2n - \sum_{j=5}^5 (j - 4) c_j = 2n - c_5.$$

For the mechanism shown in Figure I.2.15 the mobility table is given in Table I.2.5.

There are three translational joints of class 5 ( $c_5 = 3$ ) in the system:

- at  $B$  there is one translational joint between link 0 and link 1;
- at  $C$  there is one translational joint between link 1 and link 2;
- at  $D$  there is one translational joint between link 2 and link 0.

The number of DOF for this mechanism with two moving links ( $n = 2$ ) is given by

$$M = 2n - c_5 = 2(2) - (3) = 1.$$

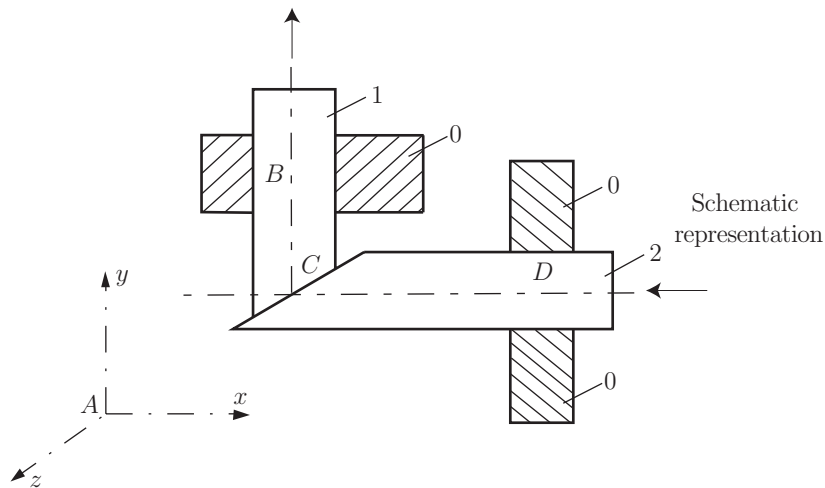
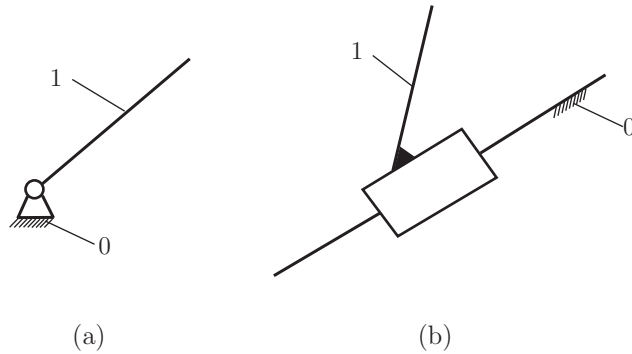


FIGURE I.2.15 Spatial mechanism of family  $f = 4$ .

TABLE I.2.5 Mobility Table for the Mechanism Shown in Figure I.2.15

| Link | $T_x$ | $T_y$ | $T_z$ | $R_x$ | $R_y$ | $R_z$ |
|------|-------|-------|-------|-------|-------|-------|
| 0    | No    | No    | No    | No    | No    | No    |
| 1    | No    | Yes   | No    | No    | No    | No    |
| 2    | Yes   | No    | No    | No    | No    | No    |
|      |       |       | No    | No    | No    | No    |

For all links  $T_z = \text{No}$  &  $R_x = \text{No}$  &  $R_y = \text{No}$  &  $R_z = \text{No} \implies f = 4$ .



**FIGURE I.2.16** Spatial mechanism of family  $f = 5$ : (a) driver link with rotational motion, and (b) driver link with translational motion.

### Mechanisms of family $f = 5$

The number of DOF for mechanisms of family  $f = 5$  is equal with the number of moving links:

$$M = n.$$

The driver link with rotational motion [Fig. I.2.16(a)] and the driver link with translational motion [Fig. I.2.16(b)] are in the  $f = 5$  category.

## I.2.4 Planar Mechanisms

For the special case of planar mechanisms ( $f = 3$ ) the Eq. (I.2.1) has the form,

$$M = 3n - 2c_5 - c_4, \quad (I.2.2)$$

where  $n$  is the number of moving links,  $c_5$  is the number of full joints (one DOF), and  $c_4$  is the number of half joints (two DOF).

There is a special significance to kinematic chains which do not change their DOF after being connected to an arbitrary system. Kinematic chains defined in this way are called *system groups* or *fundamental kinematic chains*. Connecting them to or disconnecting them from a given system enables given systems to be modified or structurally new systems to be created while maintaining the original DOF. The term *system group* has been introduced for the classification of planar mechanisms used by Assur and further investigated by Artobolevski. Limited to planar systems from Eq. (I.2.2), it can be obtained

$$3n - 2c_5 = 0, \quad (I.2.3)$$

according to which the number of system group links  $n$  is always even. In Eq. (I.2.3) there are no two DOF joints because a half joint,  $c_4$ , can be substituted with two full joints and an extra link (see Section I.2.15).

## I.2.5 Dyads

The simplest fundamental kinematic chain is the binary group with two links ( $n = 2$ ) and three full joints ( $c_5 = 3$ ). The binary group is also called a *dyad*. The sets of links shown in Figure I.2.17 are dyads and one can distinguish the following classical types:

- rotation rotation rotation (dyad RRR) or dyad of type one  $D10$  [Fig. I.2.17(a)];
- rotation rotation translation (dyad RRT) or dyad of type two  $D20$  [Fig. I.2.17(b)];
- rotation translation rotation (dyad RTR) or dyad of type three  $D30$  Fig. I.2.17(c);
- translation rotation translation (dyad TRT) or dyad of type four  $D40$  [Fig. I.2.17(d)];
- translation translation rotation (dyad TTR) or dyad of type five  $D50$  [Fig. I.2.17(e)].

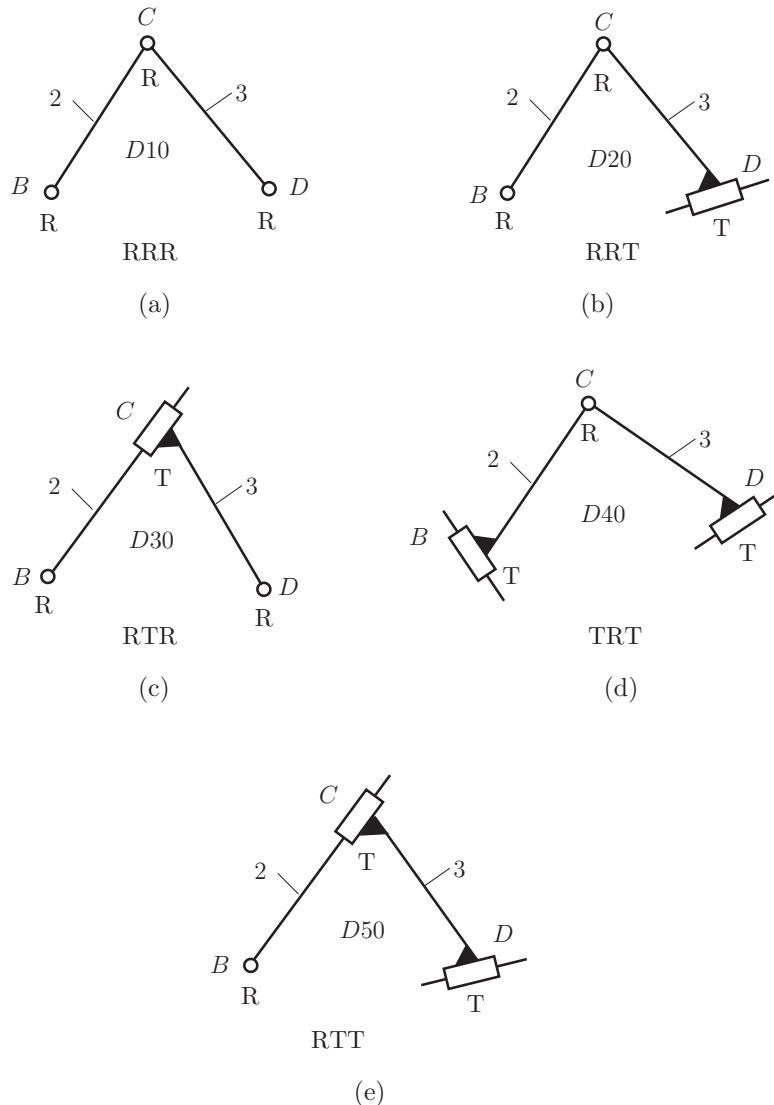
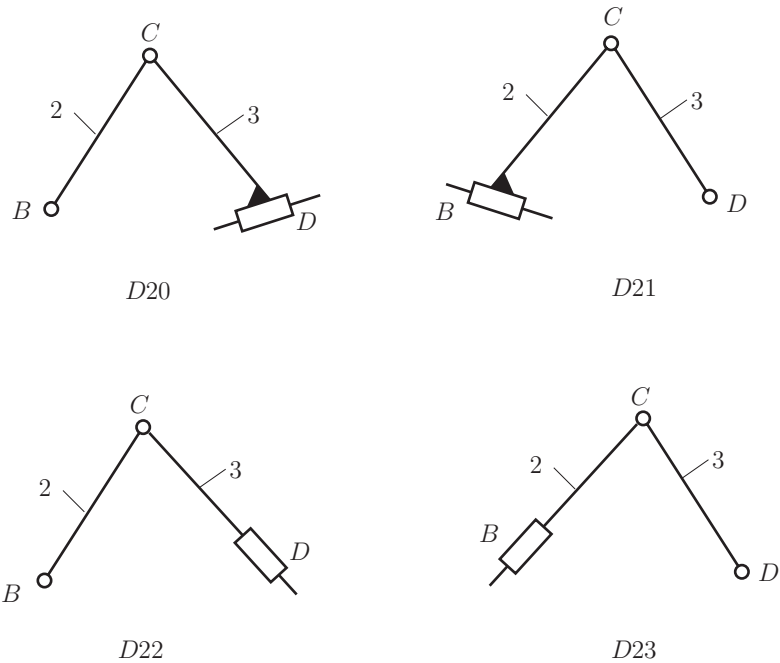


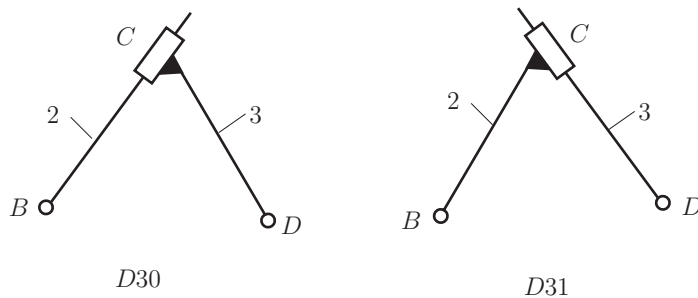
FIGURE I.2.17 Types of dyads: (a) RRR, (b) RRT, (c) RTR, (d) TRT, and (e) TTR.



**FIGURE I.2.18** RRT dyads.

The advantage of the group classification of a system lies in its simplicity. The solution of the whole system can then be obtained by composing partial solutions. Different versions of dyads exist for each classical dyad [40, 41, 42].

For the classical dyad RRT or  $D20$  there are three more different versions,  $D21$ ,  $D22$ ,  $D23$ , as shown in Figure I.2.18. For the classical dyad RTR or  $D30$  there is one different version,  $D31$ , as shown in Figure I.2.19. Figure I.2.20 shows three different versions,  $D41$ ,  $D42$ ,  $D43$ , of the dyad TRT or  $D40$ . Figure I.2.21 shows seven different versions,  $D51, D52, \dots, D57$ , of the dyad TTR or  $D50$ . In this way 19 dyads,  $D_{ij}$ , can be obtained where  $i$  represents the type and  $j$  represents the version.



**FIGURE I.2.19** RTR dyads.

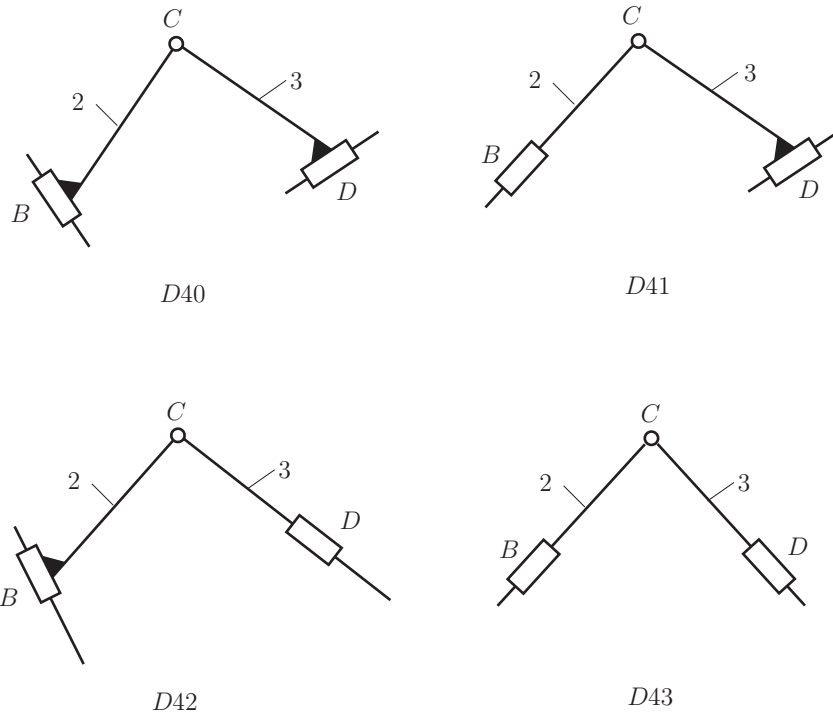


FIGURE I.2.20 TRT dyads.

## I.2.6 Mechanisms with One Dyad

One can connect a dyad to a driver link to create a mechanism with one DOF. The driver link 1 (link  $AB$ ) can have rotational (R) or translational motion (T). The driver link is connected to a first dyad comprised of the links 2 and 3, and with three joints at  $B$ ,  $C$ , and  $D$ . The driver link 1 and the last link 3 are connected to the ground 0.

The closed chain R-D42 represents a mechanism with a driver link 1, with rotational motion (R) and one dyad D42 [Fig. I.2.22(a)]. Figure I.2.22(b) shows a mechanism R-D20 where the dyad D20 has the length  $l_3 = 0$ .

Figure I.2.23 shows a mechanism T-D54. The mechanism has one contour with one rotational joint at  $A$  and three translational joints at  $A$ ,  $B$ , and  $C$ . The angles  $\alpha$  and  $\beta$  are constant angles. From the relations

$$\alpha = \phi + \beta = \text{constant} \quad \text{and} \quad \beta = \text{constant},$$

it results in the angle  $\phi = \text{constant}$ . With  $\phi = \text{constant}$  the link 2 has a translational motion in plane. The mechanism has the family  $f = 4$  and it is a *degenerate mechanism*. In general, the planar mechanisms (Fig. I.2.23) have the family  $f = 3$  with two translations and one rotation. The rotational joint at  $A$  is superfluous. For a closed chain to function as a family  $f = 3$  mechanism there must be at least two rotational joints for each contour.

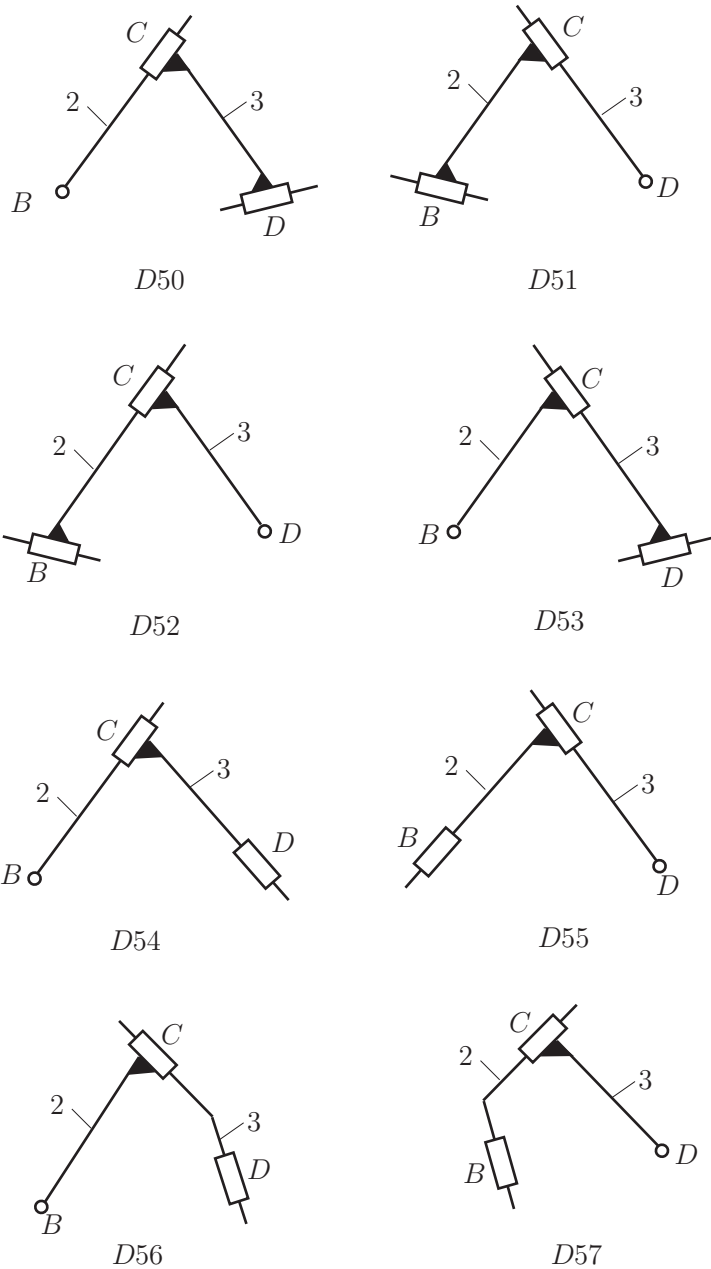


FIGURE I.2.21 TTR dyads.

## I.2.7 Mechanisms with Two Dyads

There are also mechanisms with one driver link and two dyads. The second dyad is comprised of the links 4 and 5 and three joints at  $B'$ ,  $C'$ , and  $D'$ .

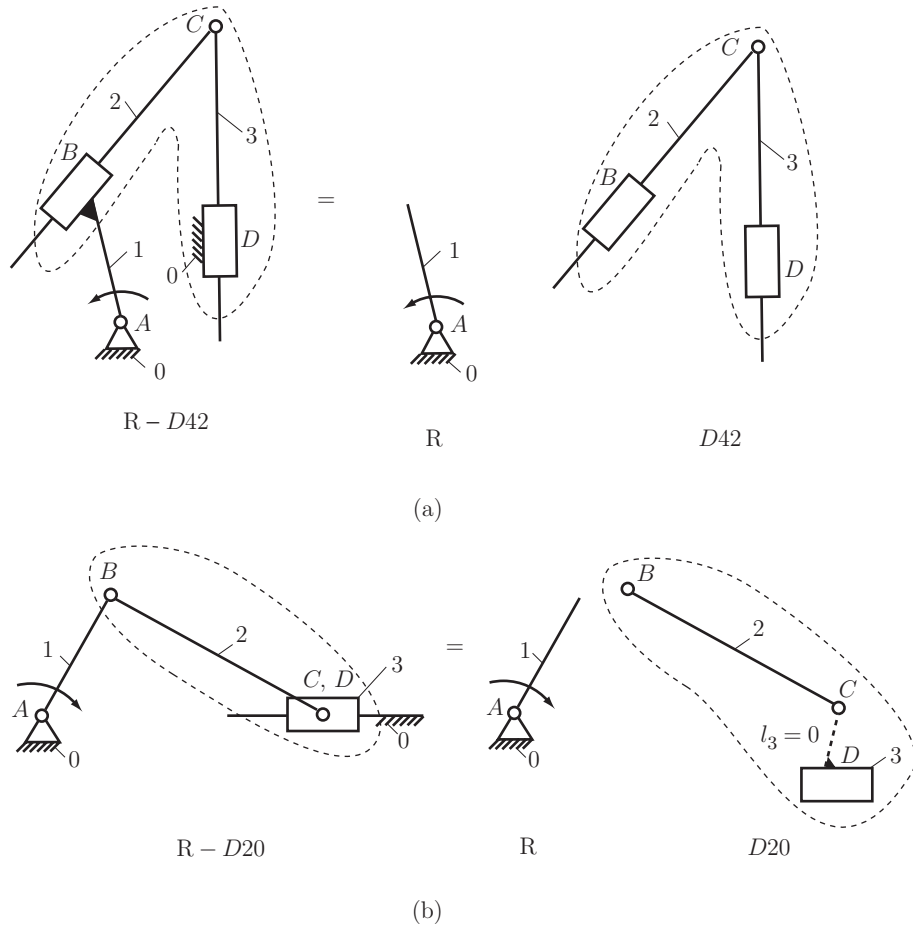


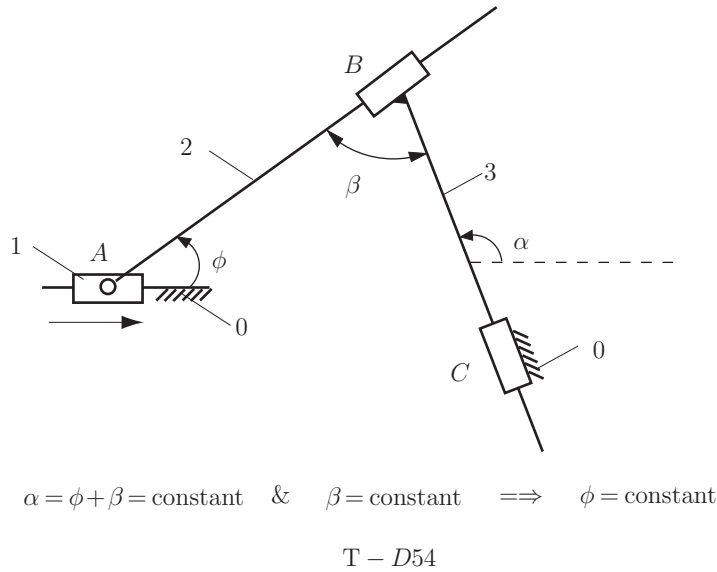
FIGURE I.2.22 Planar mechanisms: (a) R-D42 and (b) R-D20.

Figure I.2.24 represents the ways the second dyad can be connected to the initial mechanism with one driver and one dyad. For simplification only rotational joints are considered for the following mechanism examples, R-D10–D10.

Figure I.2.24(a) shows the first link of the second dyad, link 4, connected to the driver link 1, and the second link of the second dyad, link 5, connected to ground 0. The symbolization of the dyad connection is  $1 + 0$ .

Figure I.2.24(b) shows the first link of the second dyad, link 4, connected to the driver link 1, and the second link of the second dyad, link 5, connected to link 2 of the first dyad. The symbolization of the dyad connection is  $1 + 2$ .

Figure I.2.24(c) shows the first link of the second dyad, link 4, connected to link 2 of the first dyad, and the second link of the second dyad, link 5, connected to ground 0. The symbolization of the dyad connection is  $2 + 0$ .



**FIGURE I.2.23** Planar T-D54 mechanism with  $f = 4$ .

Figure I.2.24(d) shows the first link of the second dyad, link 4, connected to link 2 of the first dyad, and the second link of the second dyad, link 5, connected to link 3 of the first dyad. The symbolization of the dyad connection is  $2 + 3$ .

Figure I.2.24(e) shows the first link of the second dyad, link 4, connected to link 3 of the first dyad, and the second link of the second dyad, link 5, connected to ground 0. The symbolization of the dyad connection is  $3 + 0$ .

Figure I.2.24(f) shows the first link of the second dyad, link 4, connected to the driver link 1, and the second link of the second dyad, link 5, connected to link 3 of the first dyad. The symbolization of the dyad connection is  $1 + 3$ .

Figure I.2.25 represents mechanisms with two dyads with rotational and translational joints and their symbolization. Figure I.2.25(a) shows a rotational driver link, R, connected to a first dyad, D21. The first link 4 of the second dyad D30 is connected to the driver link 1 at  $B'$ , and the second link 5 of the second dyad D30 is connected to link 3 at  $D'$ . The symbolization of the mechanism is R-D21-D30-1+3.

Figure I.2.25(b) shows a rotational driver link, R, connected to a first dyad, D43. The first link 4 of the second dyad D50 is connected to link 2 at  $B'$ , and the second link 5 of the second dyad D30 is connected to ground 0 at  $D'$ . The symbolization of the mechanism is R-D43-D50-2+0.

Figure I.2.25(c) shows a mechanism R-D31-D20-3+0. The driver link 1, with rotational motion is connected to the first dyad D31. The first link 4 of the second dyad D20 is connected to the link 3, and the second link 5 is connected to the ground 0.

Figure I.2.26 shows a mechanism T-D21-D50-2+0. There are two contours: 0-1-2-3-0 and 0-1-2-4-5-0. The first contour, 0-1-2-3-0, has translational joints at A and B

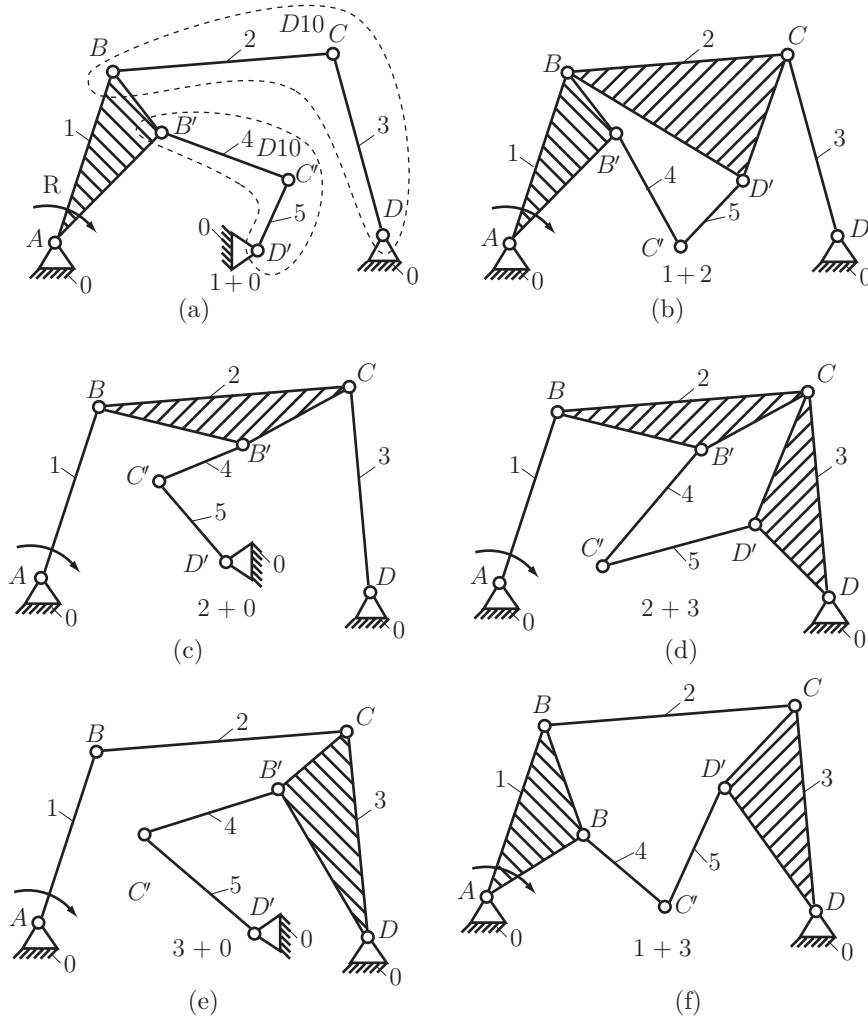
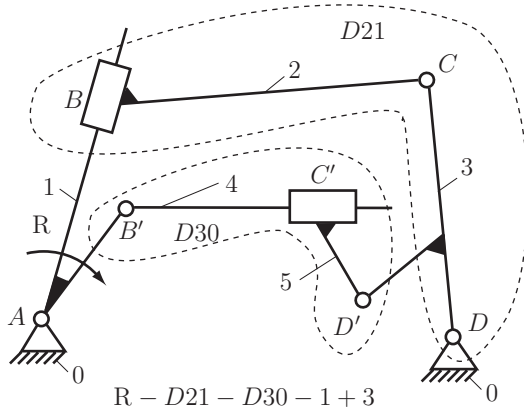


FIGURE I.2.24 Mechanism with two dyads: R-D10-D10.

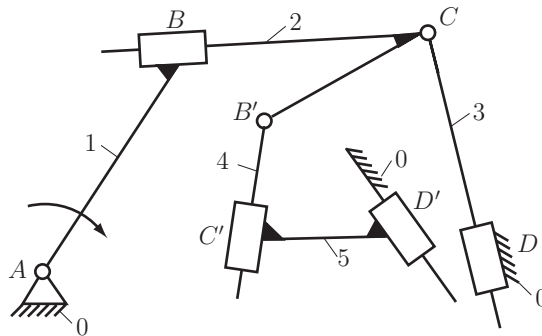
and rotational joints at  $C$  and  $D$ . The family of this contour is  $f_I = 3$ . The second contour, 0-1-2-4-5-0, has translational joints at  $A$ ,  $B$ ,  $C'$ , and  $D'$  and one rotational joint at  $B'$ .

- The angle  $\phi = \text{constant}$  and the angle  $\lambda_1 = \text{constant}$ . Then the angle  $\alpha = \phi - \lambda_1 = \text{constant}$ .
- The angle  $\lambda_2 = \text{constant}$ . Then the angle  $\gamma = \alpha + \lambda_2 = \text{constant}$ .
- The angle  $\theta = \text{constant}$  and the angle  $\lambda_3 = \text{constant}$ . Then the angle  $\delta = \theta + \lambda_3 = \text{constant}$ .

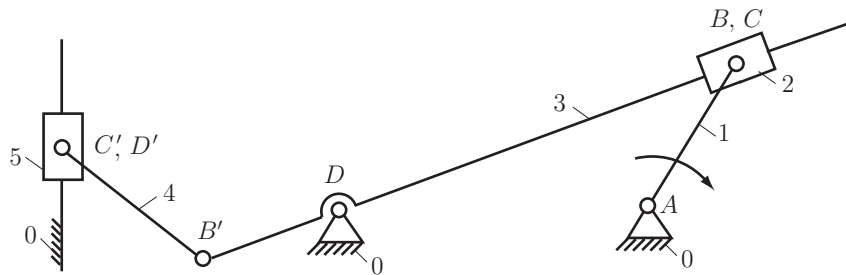
With  $\gamma = \text{constant}$  and  $\delta = \text{constant}$ , the links 2 and 4 have a translational motion in plane. The second contour has the family  $f_{II} = 4$  and the mechanism is a degenerate



(a)

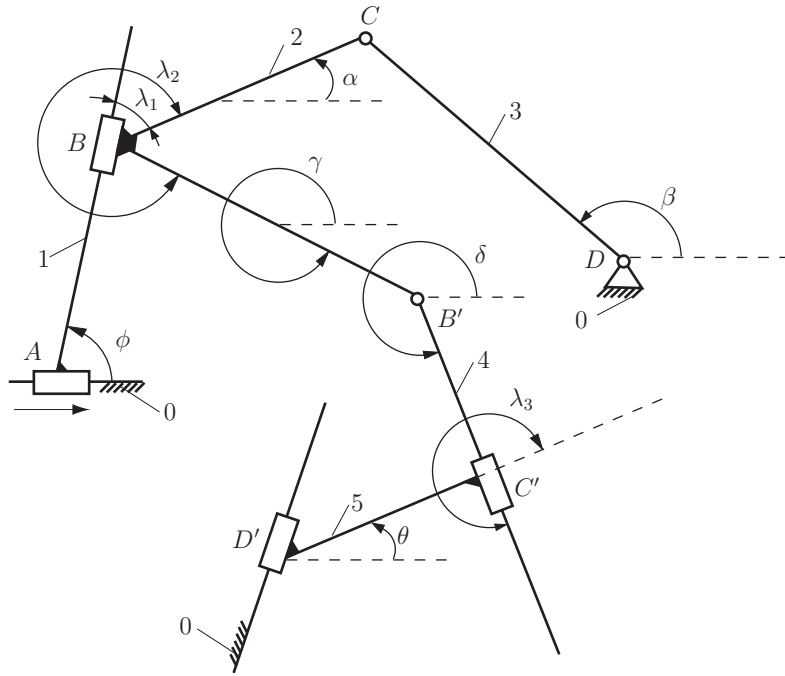


(b)



(c)

**FIGURE I.2.25** Mechanisms with two dyads: (a)  $R-D21-D30-1+3$ , (b)  $R-D43-D50-2+0$ , and (c)  $R-D31-D20-3+0$ .



$$T - D21 - D50 - 2 + 0$$

FIGURE I.2.26 *T-D21-D50-2+0 mechanism.*

mechanism. The closed contours that do not have a minimum of two rotational joints are contours of family  $f = 4$ .

To calculate the number of degrees of freedom for kinematic chains with different families the following formula is introduced [1]:

$$M = (6 - f_a)n - \sum_{j=f+1}^5 (j - f_a)c_j, \quad (I.2.4)$$

where  $f_a$  is the *apparent family*.

For the mechanism in Figure I.2.26 with two contours, the apparent family is

$$f_a = \frac{f_I + f_{II}}{2} = \frac{3 + 4}{2} = \frac{7}{2},$$

and the number of degrees of freedom of the degenerate mechanism is

$$M = (6 - f_a)n - (5 - f_a)c_5 = \left(6 - \frac{7}{2}\right)4 - \left(5 - \frac{7}{2}\right)6 = 1. \quad (I.2.5)$$

There are  $n = 4$  moving links (link 2 and link 4 form one moving link) and  $c_5 = 6$ .

## I.2.14 Decomposition of Kinematic Chains

A planar mechanism is shown in Figure I.2.47(a). This kinematic chain can be decomposed into system groups and driver links. The mobility of the mechanism will be determined first. The number of DOF for this mechanism is given by  $M = 3n - 2c_5 - c_4 = 3n - 2c_5$ .

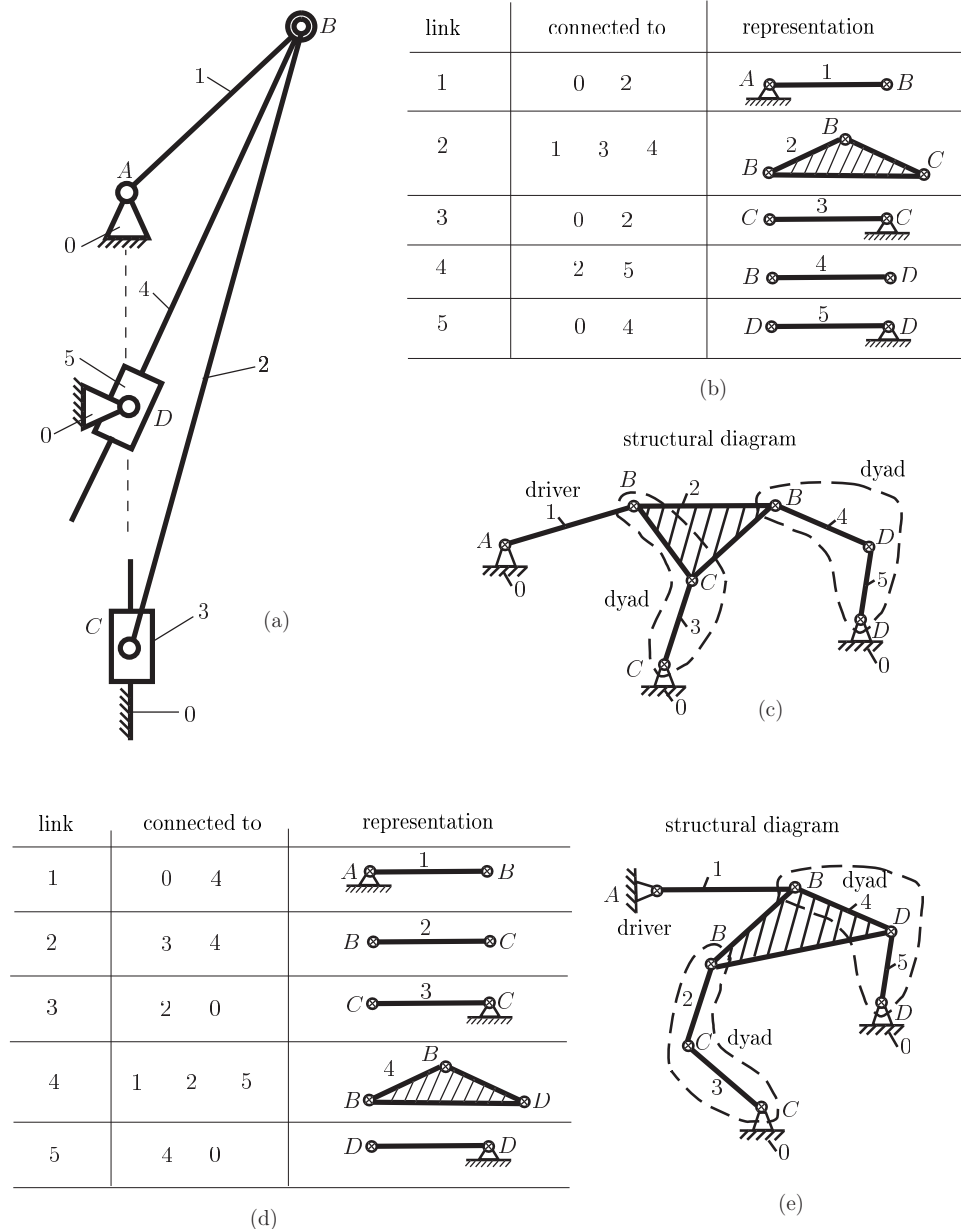


FIGURE I.2.47 Planar R-RRT-RTR mechanism.

The mechanism has five moving links ( $n = 3$ ). To find the number of  $c_5$  a *connectivity table* will be used, Figure I.2.47(b). The links are represented with bars (binary links) or triangles (ternary links). The one DOF joints (rotational joint or translation joint) are represented with a cross circle. The first column has the number of the current link, the second column shows the links connected to the current link, and the last column contains the graphical representation. The link 1 is connected to ground 0 at  $A$  and to link 2 at  $B$  [Fig. I.2.47(b)]. Next, link 2 is connected to link 1 at  $B$ , link 3 at  $C$ , and link 4 at  $B$ . Link 2 is a ternary link because it is connected to three links. At  $B$  there is a multiple joint, two rotational joints, one joint between link 1 and link 2, and one joint between link 2 and link 4. Link 3 is connected to ground 0 at  $C$  and to link 2 at  $C$ . At  $C$  there is a joint between link 3 and link 0 and a joint between link 3 and link 2. Link 4 is connected to link 2 at  $B$  and to link 5 at  $D$ . The last link, 5, is connected to link 4 at  $D$  and to ground 0 at  $D$ . In this way the table in Figure I.2.47(b) is obtained. The *structural diagram* is obtained using the graphical representation of the table connecting all the links Figure I.2.47(c). The  $c_5$  joints (with cross circles), all the links, and the way the links are connected are all represented on the structural diagram. The number of one DOF joints is given by the number of cross circles. From Figure I.2.47(c) it results  $c_5 = 7$ . The number of DOF for the mechanism is  $M = 3(5) - 2(7) = 1$ . If  $M = 1$ , there is just one driver link. One can choose link 1 as the driver link of the mechanism. Once the driver link is taken away from the mechanism the remaining kinematic chain (links 2, 3, 4, 5) has the mobility equal to zero. The dyad is the simplest system group and has two links and three joints. On the structural diagram one can notice that links 2 and 3 represent a dyad and links 4 and 5 represent another dyad. The mechanism has been decomposed into a driver link (link 1) and two dyads (links 2 and 3, and links 4 and 5).

The connectivity table and the structural diagram are not unique for this mechanism. The new connectivity table can be obtained in Figure I.2.47(d). Link 1 is connected to ground 0 at  $A$  and to link 4 at  $B$ . Link 2 is connected to link 3 at  $C$  and to link 4 at  $B$ . Link 3 is connected to link 2 at  $C$  and to ground 0 at  $C$ . The link 4 is connected to link 1 at  $B$ , to link 2 at  $B$ , and to link 5 at  $D$ . This time link 4 is the ternary link. Link 5 is connected to link 4 at  $D$  and to ground 0 at  $D$ . The structural diagram is shown in Figure I.2.47(e). Using this structural diagram the mechanism can be decomposed into a driver link (link 1) and two dyads (links 2 and 3, and links 4 and 5).

If the driver link is link 1, the mechanism has the same structure no matter what structural diagram [Fig. I.2.47(c) or Fig. I.2.47(e)] is used.

Next, the driver link with rotational motion (R) and the dyads are represented as shown in Figure I.2.48(a). The first dyad ( $BCC$ ) has the length between 2 and 3 equal to zero,  $l_{CC} = 0$ . The second dyad ( $BDD$ ) has the length between 5 and 0 equal to zero,  $l_{DD} = 0$ . Figure I.2.48(b) shows the dyads with the lengths  $l_{CC}$  and  $l_{DD}$  different than zero. Using Figure I.2.48(b), the first dyad ( $BCC$ ) has a rotational joint at  $B(R)$ , a rotational joint at  $C(R)$ , and a translational joint at  $C(T)$ . The first dyad ( $BCC$ ) is a rotation rotation translation dyad (dyad RRT). Using Figure I.2.48(b), the second dyad ( $BDD$ ) has a rotational joint at  $B(R)$ , a translational joint at  $D(T)$ , and a rotational joint at  $D(R)$ . The second dyad ( $BDD$ ) is a rotation translation rotation dyad (dyad RTR). The mechanism is an R-RRT-RTR mechanism.

The mechanism in Figure I.2.49(a) is formed by a driver 1 with rotational motion R [Fig. I.2.49(b)], a dyad RTR [Fig. I.2.49(c)], and a dyad RTR [Fig. I.2.49(d)]. The mechanism in Figure I.2.49(a) is an R-RTR-RTR mechanism. The connectivity table is shown in Figure I.2.50(a) and the structural diagram is represented in Figure I.2.50(b).

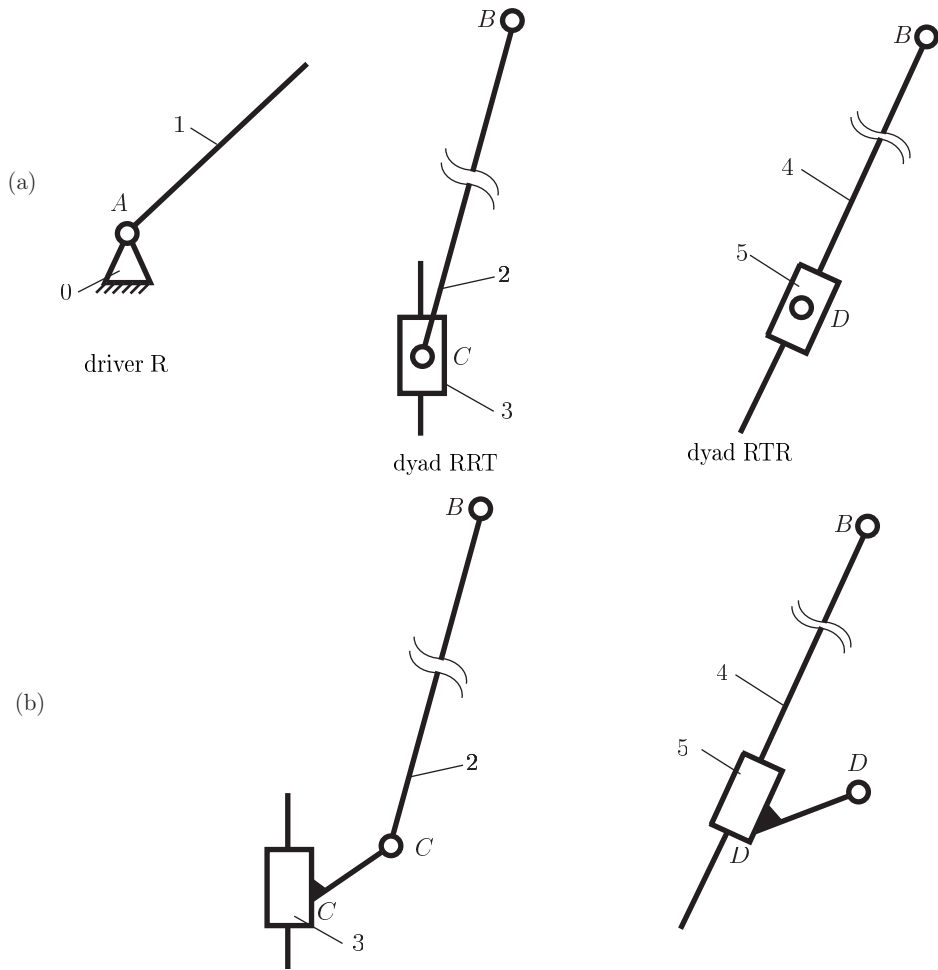


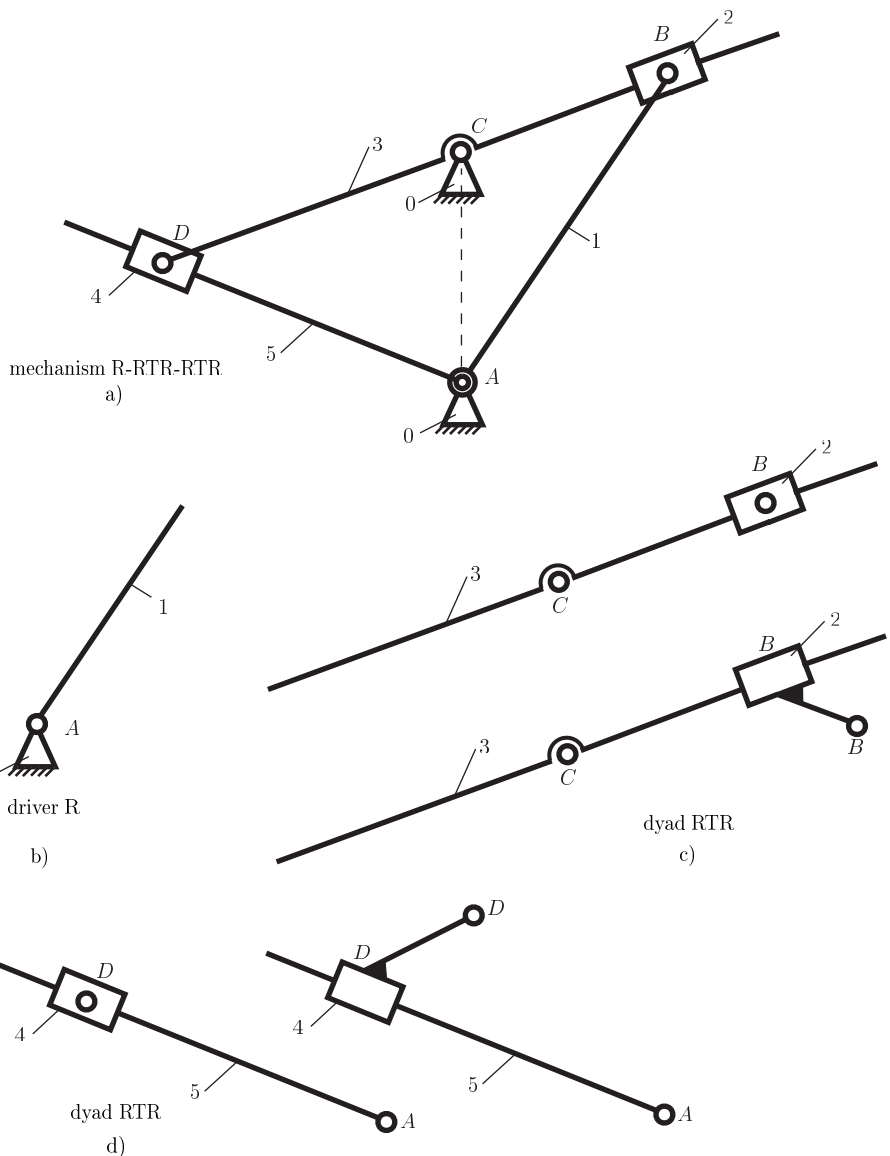
FIGURE I.2.48 Driver link and dyads for R-RRT-RTR mechanism.

## I.2.15 Linkage Transformation

For planar mechanisms the half joints can be substituted, and in this way mechanisms with just full joints are obtained. The transformed mechanism has to be equivalent with the initial mechanism from a kinematical point of view. The number of DOF of the transformed mechanism has to be equal to the number of DOF of the initial mechanism. The relative motion of the links of the transformed mechanism has to be the same as the relative motion of the links of the initial mechanism.

A half joint constrains the possibility of motion of the connected links in motion. A constraint equation can be written and the number of degrees of freedom of a half joint is  $M = -1$ . To have the same number of degrees of freedom for a kinematic chain with  $n$  moving links and  $c_5$  full joints, the following equation is obtained

$$M = 3n - 2c_5 = -1. \quad (\text{I.2.15})$$



**FIGURE I.2.49** Planar R-RTR-RTR mechanism.

The relation between the number of full joints and the number of moving links is obtained from Eq. (I.2.15).

$$c_5 = \frac{3n + 1}{2}. \tag{I.2.16}$$

A half joint can be substituted with one link ( $n = 1$ ) and two full joints ( $c_5 = 2$ ).



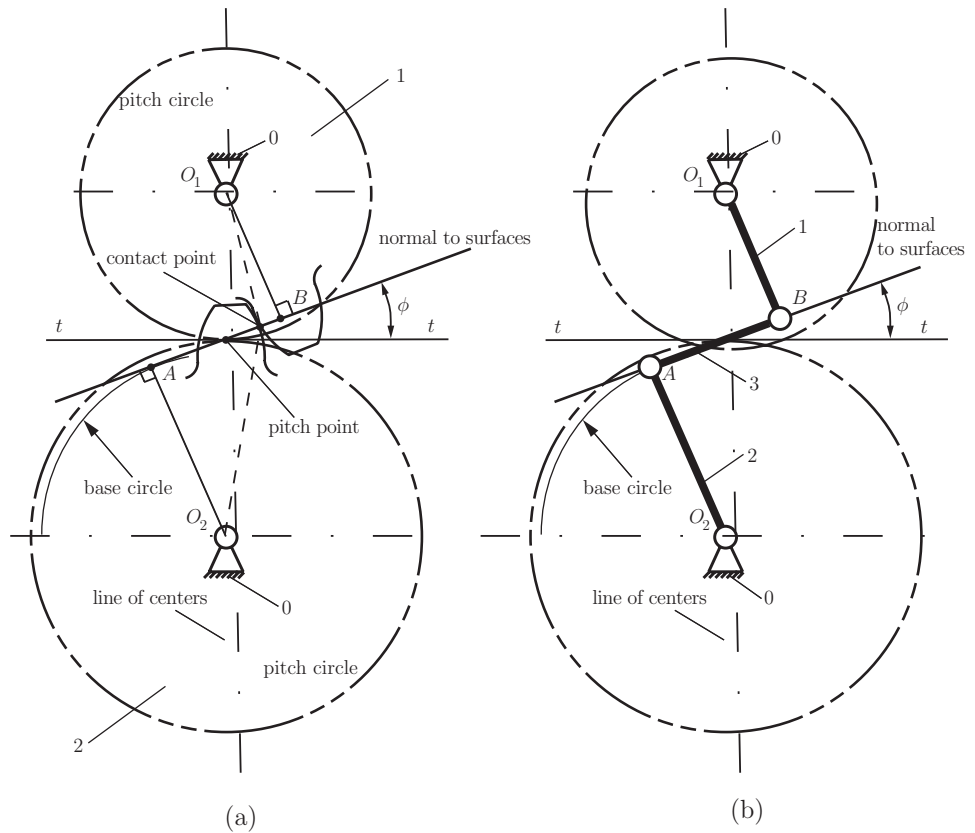


FIGURE I.2.52 Transformation of two gears in contact.

The half joint at the contact point of two gears in motion can be substituted for two full joints,  $A$  and  $B$ , and an extra link 3, between gears 1 and 2 (Fig. I.2.52). The mechanism still has one DOF, and the two-gear system (0, 1, and 2) [Fig. I.2.52(a)] is in fact a four-bar mechanism (0, 1, 2, and 3) in another disguise [Fig. I.2.52(b)]. The following relations can be written

$$O_1O_2 = \frac{m}{2} (N_1 + N_2),$$

$$O_1A = r_1 \cos \phi,$$

$$O_2B = r_2 \cos \phi,$$

$$AB = AP + PB = \frac{mN_1}{2} \sin \phi + \frac{mN_2}{2} \sin \phi = \frac{m}{2} (N_1 + N_2) \sin \phi,$$

where  $m$  is the module,  $N$  is the number of teeth,  $r$  is the pitch radius, and  $\phi$  is the pressure angle. Because  $m$ ,  $N_1$ ,  $N_2$ , and  $\phi$  are constants, the links of the four-bar mechanism [Fig. I.2.52(b)] are constant as well.

## I.2.16 Problems

I.2.1 Determine the number of degrees of freedom (DOF) of the planar elipsograph mechanism in Figure I.2.53.

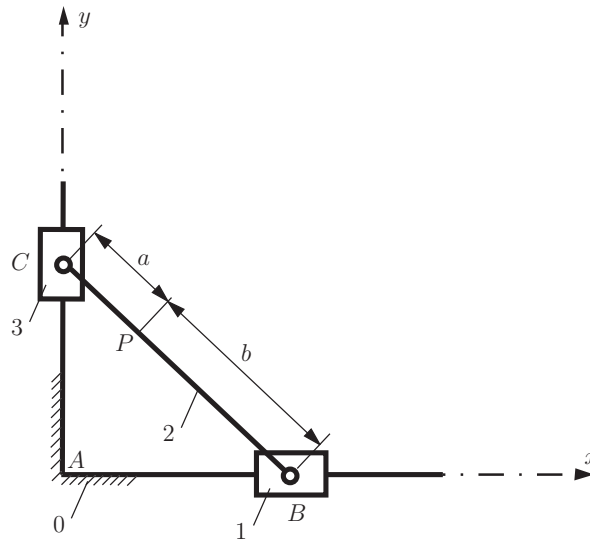


FIGURE I.2.53 Elipsograph mechanism for Problem I.2.1.

I.2.2 Find the mobility of the planar mechanism represented in Figure I.2.54.

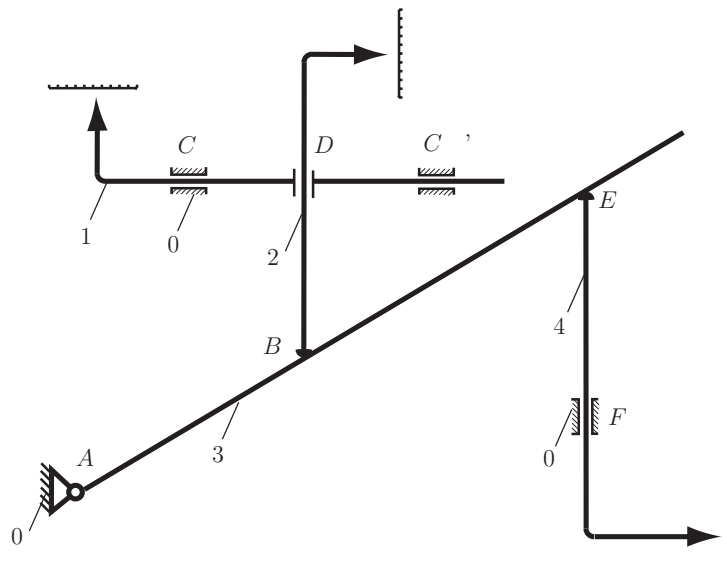


FIGURE I.2.54 Planar mechanism for Problem I.2.2.

I.2.3 Determine the family and the number of DOF for the mechanism depicted in Figure I.2.55.

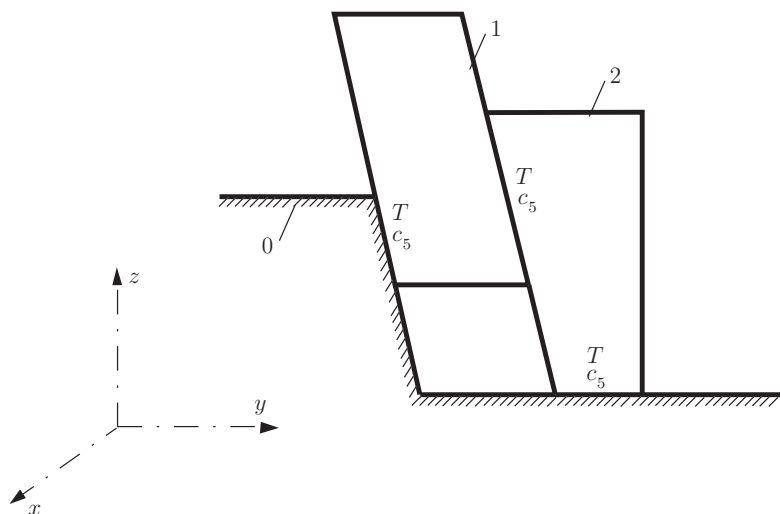


FIGURE I.2.55 Mechanism for Problem I.2.3.

I.2.4 Roller 2 of the mechanism in Figure I.2.56 undergoes an independent rotation about its axis which does not influence the motion of link 3. The purpose of element 2 is to substitute the sliding friction with a rolling friction. From a kinematical point of view, roller 2 is a passive element. Find the number of DOF.

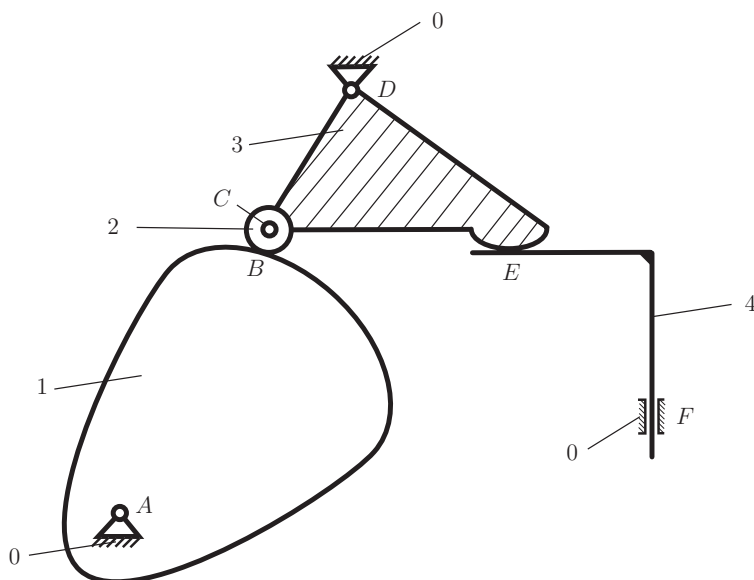
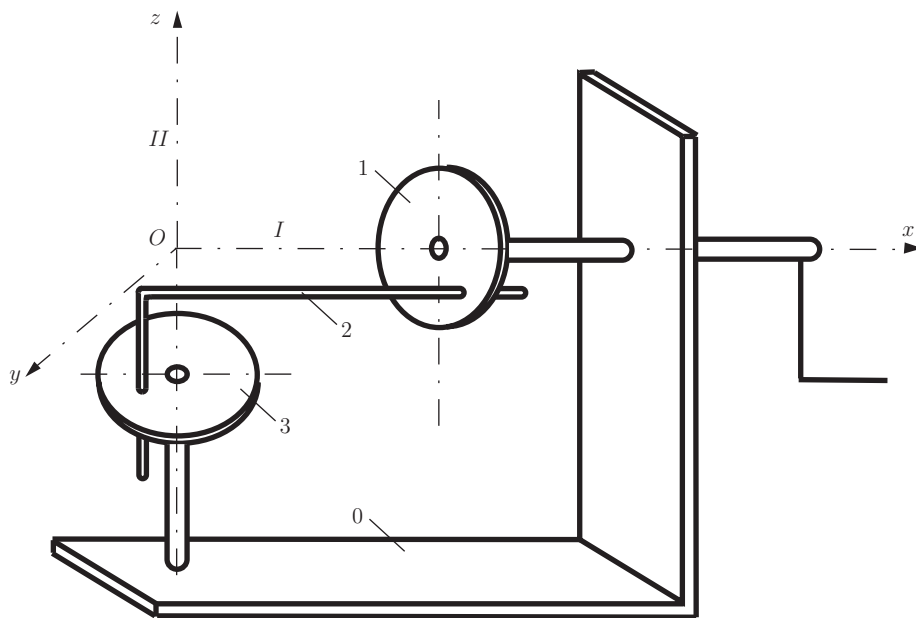


FIGURE I.2.56 Mechanism with cam for Problem I.2.4.

I.2.5 Find the family and the number of DOF of the mechanism in Figure I.2.57.



Schematic representation

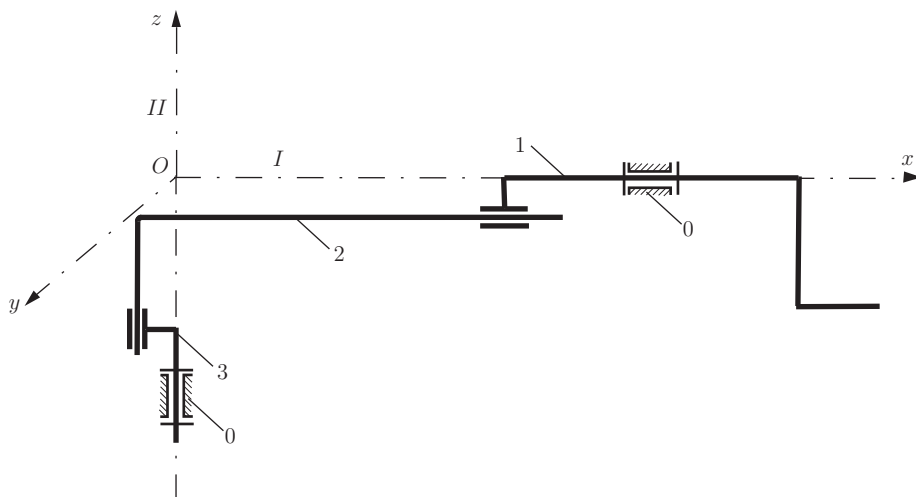


FIGURE I.2.57 Mechanism for Problem I.2.5.



I.2.8 Determine the family and the number of DOF for the mechanism in Figure I.2.60.

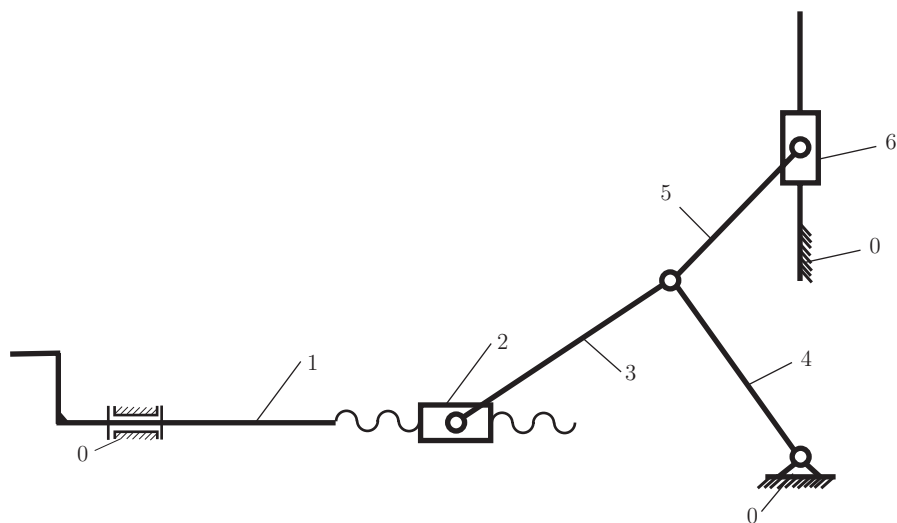


FIGURE I.2.60 Mechanism for Problem I.2.8.

I.2.9 Find the family and the number of DOF for the mechanism shown in Figure I.2.61.

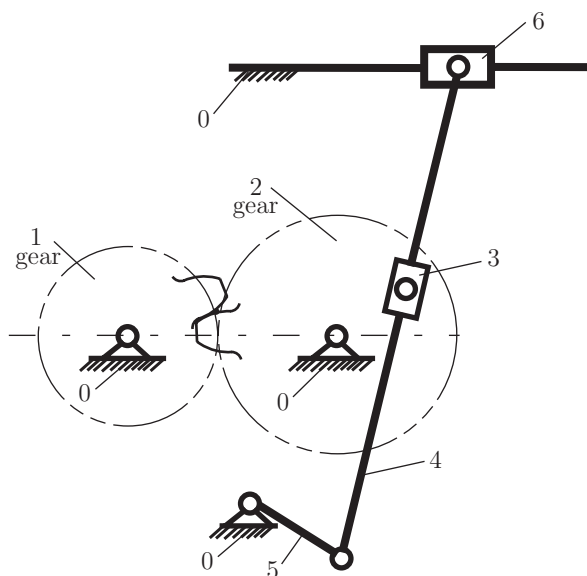
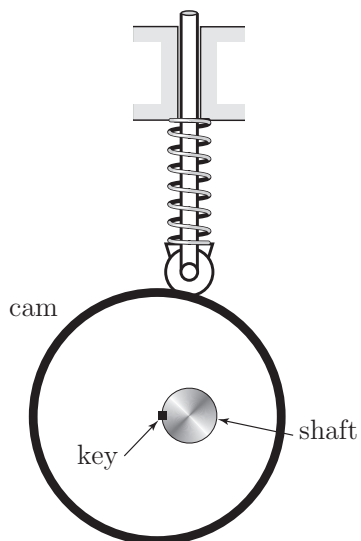


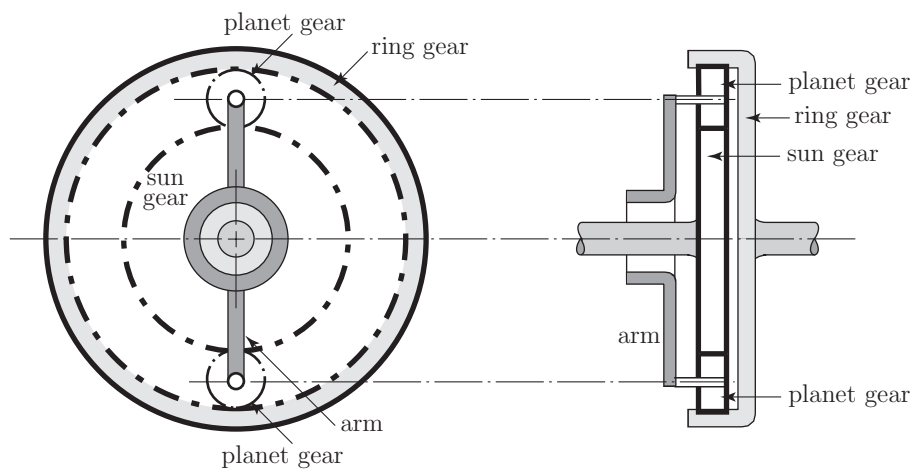
FIGURE I.2.61 Mechanism for Problem I.2.9.

I.2.10 Determine the number of DOF for the cam mechanism in Figure I.2.62.



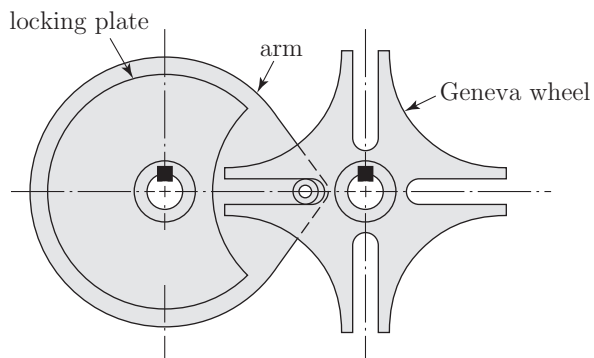
**FIGURE I.2.62** Cam mechanism for Problem I.2.10.

I.2.11 Find the number of DOF for the planetary gear train in Figure I.2.63.



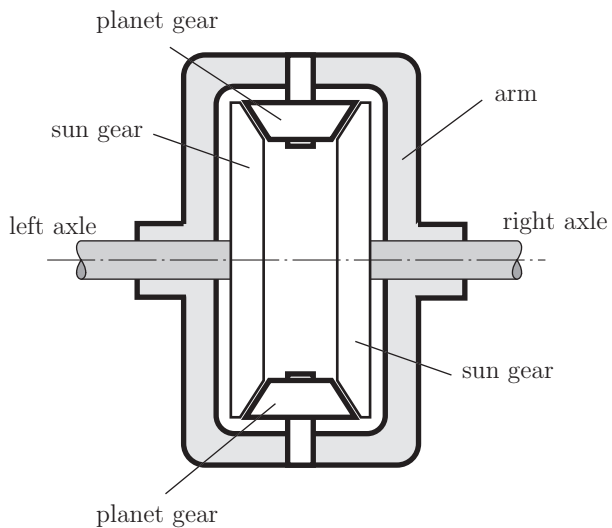
**FIGURE I.2.63** Planetary gear train for Problem I.2.11.

I.2.12 Determine the number of DOF for the Geneva mechanism in Figure I.2.64.



**FIGURE I.2.64** Geneva mechanism for Problem I.2.12.

I.2.13 Find the number of DOF for the planetary gear train in Figure I.2.65.



**FIGURE I.2.65** Planetary gear train for Problem I.2.13.