

Problem Set 4

Problem 4.1 Moment of inertia by integration

Determine the moment of inertia of the shaded area about the y -axis.

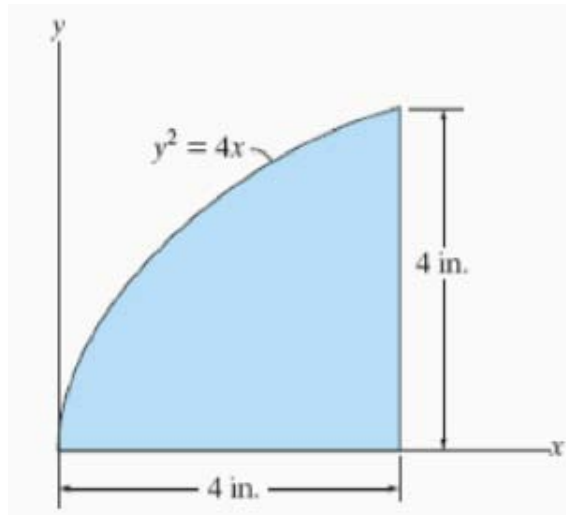

Figure P4.1: Problem 4.1

Problem 4.2 Moment of inertia of composite cross section

Determine \bar{y} which locates the centroidal x' -axis, for the cross section of the beam, and then find the moments of inertia $I_{x'x'}$ and I_{yy} .

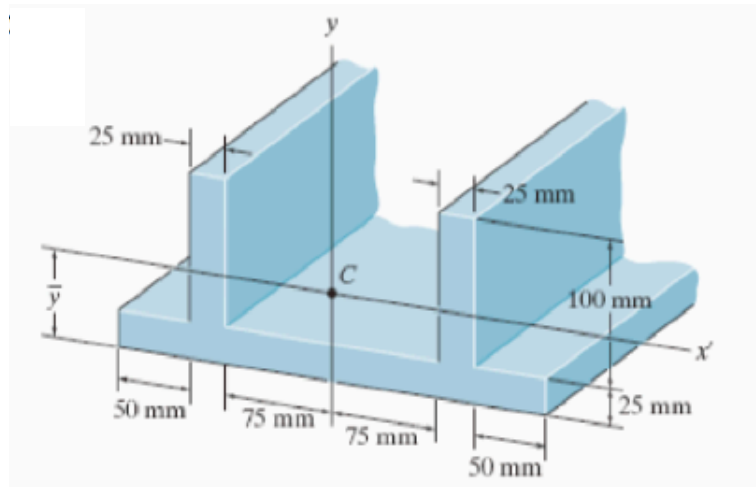

Figure P4.2: Problem 4.2

Problem 4.3

Determine the moment of inertia about the x -axis of the shaded area shown in Fig. P4.3 where $m = h/b$ and $b = h = 1$ m. Use integration.

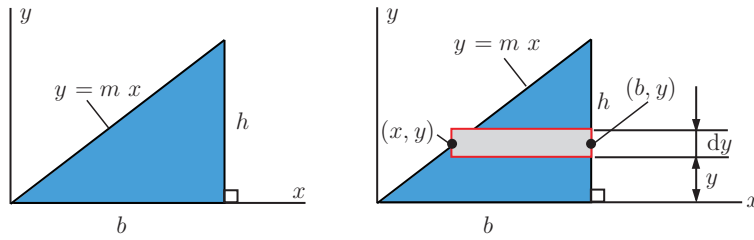

Figure P4.3: Problem 4.3

Problem 4.4

Determine the moments of inertia and the products of inertia about the centroidal axes of the shaded area shown in Fig. P4.4, where $a = 1$ in. Find the centroidal polar moment of inertia. The mass center of the shaded area is at C .

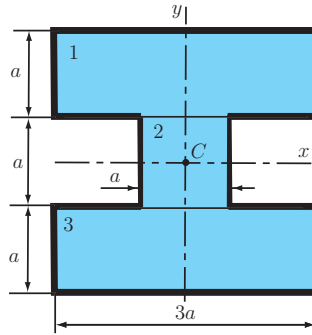

Figure P4.4: Problem 4.4

Solution

```
% ICxx = b h^3/12; ICyy = h b^3/12
% upper rectagle 1
A1 = 3*a^2;
IC1xx = (3*a)*a^3/12; IC1yy = a*(3*a)^3/12;
Ixx1 = IC1xx + (a^2)*A1; Iyy1 = IC1yy + 0*A1;
% Ixx1 = (13*a^4)/4 = 3.250 (in^4)
% Iyy1 = (9*a^4)/4 = 2.250 (in^4)
% square 2
A2 = a^2;
IC2xx = (a)*a^3/12; IC2yy = a*(a)^3/12;
Ixx2 = IC2xx + 0*A2; Iyy2 = IC2yy + 0*A2;
% Ixx2 = a^4/12 = 0.083 (in^4)
% Iyy2 = a^4/12 = 0.083 (in^4)
% lower rectagle 3
A3 = 3*a^2;
IC3xx = (3*a)*a^3/12; IC3yy = a*(3*a)^3/12;
Ixx3 = IC3xx + (a^2)*A3; Iyy3 = IC3yy + 0*A3;
% Ixx3 = (13*a^4)/4 = 3.250 (in^4)
% Iyy3 = (9*a^4)/4 = 2.250 (in^4)
```

```
ICxx=Ixx1+Ixx2+Ixx3; ICyy=Iyy1+Iyy2+Iyy3;
% ICxx = (79*a^4)/12 = 6.583 (in^4)
% ICyy = (55*a^4)/12 = 4.583 (in^4)
% products of inertia
% x-axis and y-axis are symmetry axes => ICxy=0
% z=0 => ICxz=ICyz=0
% centroidal polar moment
IC=ICxx+ICyy;
% IC = ICzz = (67*a^4)/6 = 11.167 (in^4)
```

Problem 4.5

Determine the moment of inertia of the area about the y -axis. Solve the problem in two ways, using rectangular differential elements: a) having a thickness dx and b) having a thickness of dy . Given: $a = 1$ in and $b = 4$ in.

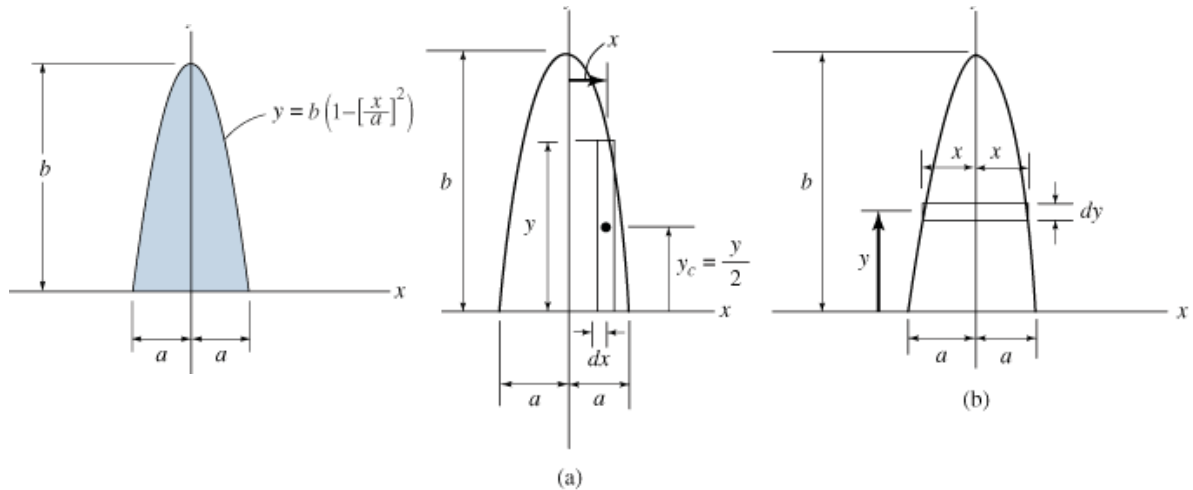

Figure P4.5: Problem 4.5

Solution

```
% a = 1; b = 4; in
y = b*(1-(x/a)^2);
```

```
% a) using a thickness dx
% area of the differential element parallel to y-axis
% dA = y dx = b*(1-(x/a)^2) dx
% Iyy = int(x^2 dA) = int(x^2*y dx) where -a<x<a
Iyy = int(x^2*y,x,-a,a);
% a) Iyy = (4*a^3*b)/15 = 1.067 (in^4)
```

```
% b) using a thickness dy
x = a*sqrt(1-y/b);
% moment of inertia of the differential element about y-axis
% dIyy = (1/12) (dy) (2 x)^3 = (1/12) (dy) (2*a*sqrt(1-y/b))^3
```

```
% Iyy = int(dIyy) where 0<y<b
Iyy = int((1/12)*(2*x)^3, y, 0, b);
% b) Iyy = (4*a^3*b)/15 = 1.067 (in^4)
```

Problem 4.6

Determine the polar moment of inertia of the area about the z -axis passing through point O .

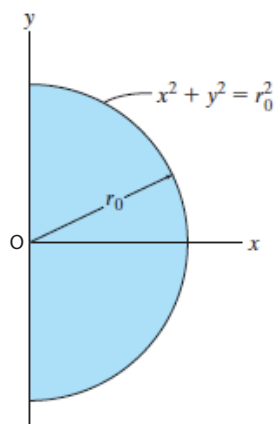

Figure P4.6: Problem 4.6

Solution

$$I_O = I_{xx} + I_{yy} = \frac{\pi r_0}{8} + \frac{\pi r_0}{8} = \frac{\pi r_0}{4}.$$

Problem 4.7

Locate the centroid y_C of the cross-sectional area for the angle. Then find the moment of inertia $I_{Cx'}$ about the Cx' centroidal axis.

Locate the centroid x_C of the cross-sectional area for the angle. Then find the moment of inertia $I_{Cy'}$ about the Cy' centroidal axis.

Given: $a = 2$ in, $b = 6$ in, $c = 6$ in, and $d = 2$ in.

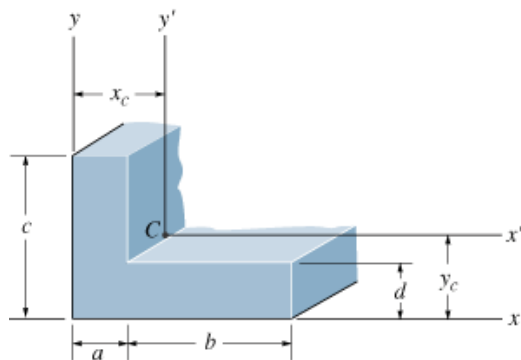

Figure P4.7: Problem 4.7