

Chapter 2

Dynamics of Particle

2.1 Newton's second law

Classical mechanics was established by Isaac Newton with the publication of *Philosophiae naturalis principia mathematica*, in 1687. Newton stated three “laws” of motion

1. When the sum of the forces acting on a particle is zero, its velocity is constant. In particular if the particle is initially stationary it will remain stationary.
2. When the sum of the forces acting on a particle is not zero the sum of the forces is equal to the rate of change of the *linear momentum* of the particle.
3. The forces exerted by two particles on each other are equal in magnitude and opposite in direction

$$\mathbf{F}_{ij} + \mathbf{F}_{ji} = \mathbf{0},$$

where \mathbf{F}_{ij} is the force exerted by particle i on particle j and \mathbf{F}_{ji} is the force exerted by particle j on particle i .

The *linear momentum* of a particle is the product of the mass of the particle, m , and the velocity of the particle, \mathbf{v}

$$\mathbf{L} = m\mathbf{v}.$$

Newton's second law may be written as

$$\mathbf{F} = \frac{d}{dt}(m\mathbf{v}), \quad (2.1)$$

where \mathbf{F} is the total force on the particle. If the mass of the particle is constant, $m = \text{constant}$, the total force equals the product of its mass and acceleration, \mathbf{a}

$$\mathbf{F} = m \frac{d\mathbf{v}}{dt} = m\mathbf{a}. \quad (2.2)$$

Newton's second law gives interpretation to the terms *mass* and *force*. In SI units, the unit of mass is the kilogram [kg]. The unit of force is the newton [N], which is the force required to give a mass of one kilogram an acceleration of one meter per second squared

$$1 \text{ N} = (1 \text{ kg}) (1 \text{ m/s}^2) = 1 \text{ kg m/s}^2.$$

In U.S. Customary units, the unit of force is the pound [lb]. The unit of mass is the slug, which is the amount of mass accelerated at one foot per second squared by a force of one pound

$$1 \text{ lb} = (1 \text{ slug}) (1 \text{ ft/s}^2), \text{ or } 1 \text{ slug} = 1 \text{ lb s}^2/\text{lb}.$$

2.2 Newtonian Gravitation

Newton's postulate for the magnitude of gravitational force F between two particles in terms of their masses m_1 and m_2 and the distance r between them, Fig. 2.1, may be expressed as

$$F = \frac{G m_1 m_2}{r^2}, \quad (2.3)$$

where G is called the *universal gravitational constant*. Equation (2.3) may be used to approximate the weight of a particle of mass m due to the gravitational attraction of the earth,

$$W = \frac{G m m_E}{r^2}, \quad (2.4)$$

where m_E is the mass of the earth and r is the distance from the center of the earth to the particle. When the weight of the particle is the only force acting on it, the resulting acceleration is called the acceleration due to gravity. In this case, Newton's second law states that $W = ma$, and from Eq. (2.4) the acceleration due to gravity is

$$a = \frac{G m_E}{r^2}. \quad (2.5)$$

The acceleration due to gravity at sea level is denoted by g . From Eq. (2.5) one may write $G m_E = g R_E^2$, where R_E is the radius of the earth. The expression for the acceleration due to gravity at a distance r from the center of the earth in terms of the

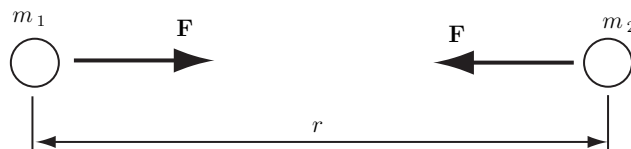

Fig. 2.1 Gravitational force between two particles

acceleration due to gravity at sea level is

$$a = g \frac{R_E^2}{r^2}. \quad (2.6)$$

At sea level, the weight of a particle is given by

$$W = m g. \quad (2.7)$$

The value of g varies on the surface of the earth from a location to another. The values of g used in examples and problems are $g = 9.81 \text{ m/s}^2$ in SI units and $g = 32.2 \text{ ft/s}^2$ in U.S. Customary units.

2.3 Inertial Reference Frames

Newton's laws don't give accurate results if a problem involves velocities that are not small compared to the velocity of light ($3 \cdot 10^8 \text{ m/s}$). Einstein's theory of relativity may be applied to such problems. Newtonian mechanics also fails in problems involving atomic dimensions. Quantum mechanics may be used to describe phenomena on the atomic scale.

The position, velocity, and acceleration of a point are specified, in general, relative to an arbitrary reference frame. The Newton's second law cannot be expressed in terms of just any reference frame. Newton stated that the second law should be expressed in terms of a reference frame at rest with respect to the "fixed stars." Newton's second law, Eq. (2.2), may be expressed in terms of a reference frame that is fixed relative to the earth. Equation (2.2) may be applied using a reference that translates at constant velocity relative to the earth. If a reference frame may be used to apply Eq. (2.2), it is said to be *Newtonian*, or *inertial* reference frame. Newton's second law may be applied with good results using reference frames that accelerate and rotate by properly accounting for the acceleration and rotation.

2.4 Cartesian Coordinates

To apply Newton's second law in a particular situation, one may choose a coordinate system. Newton's second law in a cartesian reference frame, Fig. 2.2, may be expressed as

$$\sum \mathbf{F} = m\mathbf{a}, \quad (2.8)$$

where $\sum \mathbf{F} = \sum F_x \mathbf{i} + \sum F_y \mathbf{j} + \sum F_z \mathbf{k}$ is the sum of the forces acting on a particle P of mass m , and

$$\mathbf{a} = a_x \mathbf{i} + a_y \mathbf{j} + a_z \mathbf{k} = \ddot{x} \mathbf{i} + \ddot{y} \mathbf{j} + \ddot{z} \mathbf{k},$$

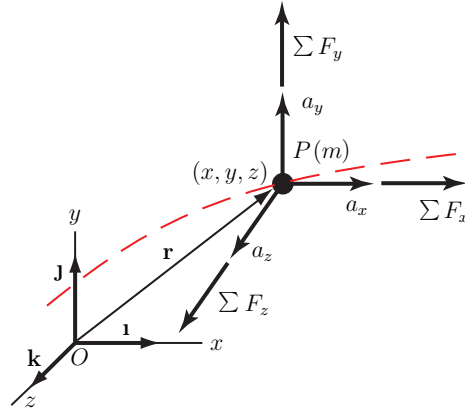

Fig. 2.2 Newton's second law in a cartesian reference frame

is the acceleration of the particle. Equating x , y , and z components, three scalar equations of motion are obtained

$$\sum F_x = ma_x = m\ddot{x}, \quad \sum F_y = ma_y = m\ddot{y}, \quad \sum F_z = ma_z = m\ddot{z}, \quad (2.9)$$

or the total force in each coordinate direction equals the product of the mass and component of the acceleration in that direction.

Projectile problem

An object P , of mass m , is launched through the air, Fig. ??3. The force on the object is just the weight of the object (the aerodynamic forces are neglected). The sum of the forces is $\sum \mathbf{F} = -m g \mathbf{j}$. From Eq. (2.9) one may obtain

$$a_x = \ddot{x} = 0, \quad a_y = \ddot{y} = -g, \quad a_z = \ddot{z} = 0.$$

The projectile accelerates downward with the acceleration due to gravity.

Straight line motion

For straight line motion along the x axis, Eq. (2.9) are

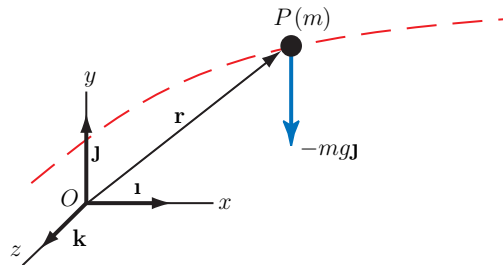

Fig. 2.3 Projectile motion

$$\sum F_x = m\ddot{x}, \sum F_y = 0, \sum F_z = 0.$$

2.5 Normal and Tangential Components

A particle P of mass m moves on a curved path Fig. 2.4. One may resolve the sum of the forces $\sum \mathbf{F}$ acting on the particle into normal F_n and tangential F_t components

$$\sum \mathbf{F} = F_t \mathbf{u}_t + F_n \mathbf{u}_n.$$

The acceleration of the particle in terms of normal and tangential components is

$$\mathbf{a} = a_t \mathbf{u}_t + a_n \mathbf{u}_n.$$

Newton's second law is

$$\begin{aligned} \sum \mathbf{F} &= m\mathbf{a}, \\ F_t \mathbf{u}_t + F_n \mathbf{u}_n &= m(a_t \mathbf{u}_t + a_n \mathbf{u}_n), \end{aligned} \quad (2.10)$$

where

$$a_t = \frac{dv}{dt} = \dot{v}, \quad a_n = \frac{v^2}{\rho}.$$

Equating the normal and tangential components in Eq. (2.10), two scalar equations of motion are obtained

$$F_t = m\dot{v}, \quad F_n = m\frac{v^2}{\rho}. \quad (2.11)$$

The sum of the forces in the tangential direction equals the product of the mass and the rate of change of the magnitude of the velocity, and the sum of the forces in the normal direction equals the product of the mass and the normal component of acceleration. If the path of the particle lies in a plane, the acceleration of the particle

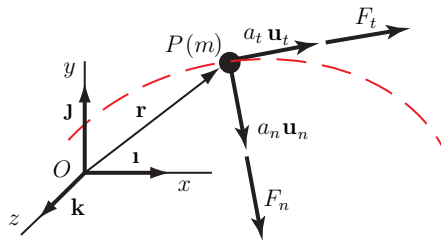

Fig. 2.4 Newton's second law in terms of normal and tangential components

perpendicular to the plane is zero and so the sum of the forces perpendicular to the plane is zero.

2.6 Polar and Cylindrical Coordinates

The particle P with the mass m moves in a plane curved path, Fig. 2.5. The motion of the particle may be described in terms of the polar coordinates. Resolving the sum of the forces parallel to the plane into radial and transverse components

$$\sum \mathbf{F} = F_r \mathbf{u}_r + F_\theta \mathbf{u}_\theta,$$

and expressing the acceleration of the particle in terms of radial and transverse components Newton's second law may be written the form

$$F_r \mathbf{u}_r + F_\theta \mathbf{u}_\theta = m(a_r \mathbf{u}_r + a_\theta \mathbf{u}_\theta), \quad (2.12)$$

where

$$a_r = \frac{d^2 r}{dt^2} - r \left(\frac{d\theta}{dt} \right)^2 = \ddot{r} - r\omega^2,$$

$$a_\theta = r \frac{d^2 \theta}{dt^2} + 2 \frac{dr}{dt} \frac{d\theta}{dt} = r\alpha + 2\dot{r}\omega.$$

Two scalar equations are obtained

$$F_r = m(\ddot{r} - r\omega^2),$$

$$F_\theta = m(r\alpha + 2\dot{r}\omega). \quad (2.13)$$

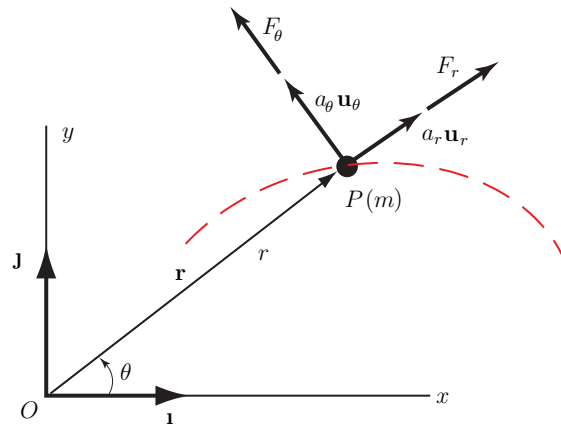

Fig. 2.5 Newton's second law in terms of polar components

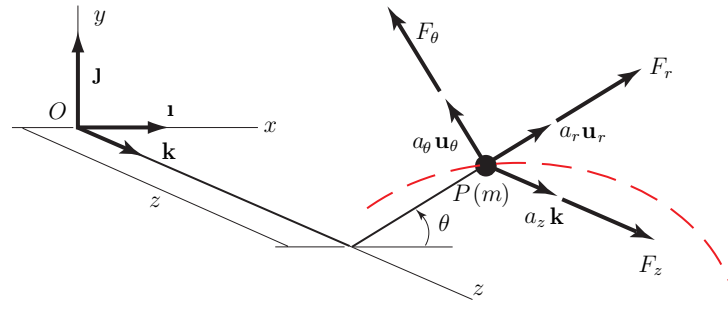

Fig. 2.6 Newton's second law in terms of cylindrical components

The sum of the forces in the radial direction equals the product of the mass and the radial component of the acceleration, and the sum of the forces the transverse direction equals the product of the mass and the transverse component of the acceleration.

The three-dimensional motion of the particle P may be obtained using the cylindrical coordinates, Fig. 2.6. The position of P perpendicular to the $x - y$ plane is measured by the coordinate z and the unit vector \mathbf{k} . The sum of the forces is resolved into radial, transverse, and z components

$$\sum \mathbf{F} = F_r \mathbf{u}_r + F_\theta \mathbf{u}_\theta + F_z \mathbf{k}.$$

The three scalar equations of motion are the radial and transverse relations, Eq. (2.13) and the equation of motion in the z direction,

$$\begin{aligned} F_r &= m(\ddot{r} - r\omega^2), \\ F_\theta &= m(r\alpha + 2\dot{r}\omega), \\ F_z &= m\ddot{z}. \end{aligned} \quad (2.14)$$

2.7 Principle of Work and Energy

The Newton's second law for a particle of mass m can be written in the form

$$\mathbf{F} = m \frac{d\mathbf{v}}{dt} = m\dot{\mathbf{v}}. \quad (2.15)$$

The dot product of both sides of Eq. (2.15) with the velocity $\mathbf{v} = d\mathbf{r}/dt$ gives

$$\mathbf{F} \cdot \mathbf{v} = m\dot{\mathbf{v}} \cdot \mathbf{v}, \quad (2.16)$$

or

$$\mathbf{F} \cdot \frac{d\mathbf{r}}{dt} = m\dot{\mathbf{v}} \cdot \mathbf{v}. \quad (2.17)$$

But

$$\frac{d}{dt}(\mathbf{v} \cdot \mathbf{v}) = \dot{\mathbf{v}} \cdot \mathbf{v} + \mathbf{v} \cdot \dot{\mathbf{v}} = 2\dot{\mathbf{v}} \cdot \mathbf{v},$$

and

$$\dot{\mathbf{v}} \cdot \mathbf{v} = \frac{1}{2} \frac{d}{dt}(\mathbf{v} \cdot \mathbf{v}) = \frac{1}{2} \frac{d}{dt}(v^2), \quad (2.18)$$

where $v^2 = \mathbf{v} \cdot \mathbf{v}$ is the square of the magnitude of \mathbf{v} . Using Eq. (2.18) one may write Eq. (2.17) as

$$\mathbf{F} \cdot d\mathbf{r} = \frac{1}{2} m d(v^2) = \frac{1}{2} m d(v^2), \quad (2.19)$$

The term

$$dU = \mathbf{F} \cdot d\mathbf{r},$$

is the *work* where \mathbf{F} is the total external force acting on the particle of mass m and $d\mathbf{r}$ is the infinitesimal displacement of the particle. Integrating Eq. (2.19) one may obtain

$$\int_{\mathbf{r}_1}^{\mathbf{r}_2} \mathbf{F} \cdot d\mathbf{r} = \int_{v_1^2}^{v_2^2} \frac{1}{2} m d(v^2) = \frac{1}{2} m v_2^2 - \frac{1}{2} m v_1^2, \quad (2.20)$$

where v_1 and v_2 are the magnitudes of the velocity at the positions \mathbf{r}_1 and \mathbf{r}_2 . The *kinetic energy* of a particle of mass m with the velocity \mathbf{v} is the term

$$T = \frac{1}{2} m \mathbf{v} \cdot \mathbf{v} = \frac{1}{2} m v^2, \quad (2.21)$$

where $|\mathbf{v}| = v$. The work done as the particle moves from position \mathbf{r}_1 to position \mathbf{r}_2 is

$$U_{12} = \int_{\mathbf{r}_1}^{\mathbf{r}_2} \mathbf{F} \cdot d\mathbf{r}. \quad (2.22)$$

The *principle of work and energy* may be expressed as

$$U_{12} = \frac{1}{2} m v_2^2 - \frac{1}{2} m v_1^2. \quad (2.23)$$

The work done on a particle as it moves between two positions equals the change in its kinetic energy.

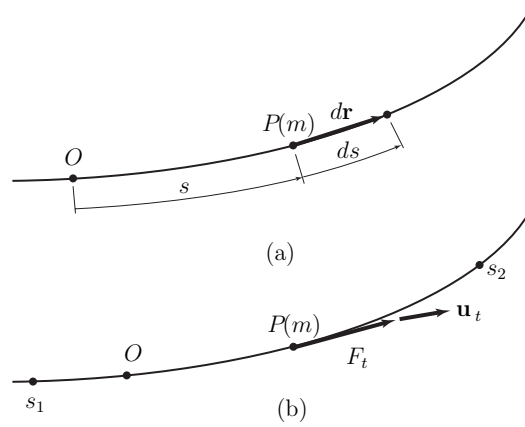

Fig. 2.7 Position of a particle in curvilinear motion

The dimensions of work, and therefore the dimensions of kinetic energy, are (force) \times (length). In U.S. Customary units, work is expressed in ft lb. In SI units, work is expressed in N m, or joules [J].

One may use the principle of work and energy on a system if no net work is done by internal forces. The internal friction forces may do net work on a system.

2.8 Work and Power

The position of a particle P of mass m in curvilinear motion is specified by the coordinate s measured along its path from a reference point O , Fig. 2.7(a). The velocity of the particle is

$$\mathbf{v} = \frac{ds}{dt} \mathbf{u}_t = \dot{s} \mathbf{u}_t,$$

where \mathbf{u}_t is the tangential unit vector.

Using the relation $\mathbf{v} = d\mathbf{r}/dt$ the infinitesimal displacement $d\mathbf{r}$ along the path is

$$d\mathbf{r} = \mathbf{v} dt = \frac{ds}{dt} \mathbf{u}_t dt = ds \mathbf{u}_t.$$

The work done by the external forces acting on the particle as result of the displacement $d\mathbf{r}$ is

$$\mathbf{F} \cdot d\mathbf{r} = \mathbf{F} \cdot ds \mathbf{u}_t = \mathbf{F} \cdot \mathbf{u}_t ds = F_t ds,$$

where $F_t = \mathbf{F} \cdot \mathbf{u}_t$ is the tangential component of the total force.

The work as the particle moves from a position s_1 to a position s_2 is, Fig. 2.7(b)

$$U_{12} = \int_{s_1}^{s_2} F_t ds. \quad (2.24)$$

The work is equal to the integral of the tangential component of the total force with respect to distance along the path. Components of force perpendicular to the path do not do any work.

The work done by the external forces acting on a particle during an infinitesimal displacement $d\mathbf{r}$ is

$$dU = \mathbf{F} \cdot d\mathbf{r}.$$

The *power*, P , is the rate at which work is done. The power P is obtained by dividing the expression of the work by the interval of time dt during which the displacement takes place

$$P = \mathbf{F} \cdot \frac{d\mathbf{r}}{dt} = \mathbf{F} \cdot \mathbf{v}.$$

In SI units, the power is expressed in newton meters per second, which is joules per second [J/s] or watts [W]. In U.S. Customary units, power is expressed in foot pounds per second or in horse-power [hp], which is 746 W or approximately 550 ft lb/s.

The power is also the rate of change of the kinetic energy of the object

$$P = \frac{d}{dt} \left(\frac{1}{2}mv^2 \right).$$

Work done on a particle by a linear spring

A linear spring connects a particle P of mass m to a fixed support, Fig. 2.8. The force exerted on the particle is

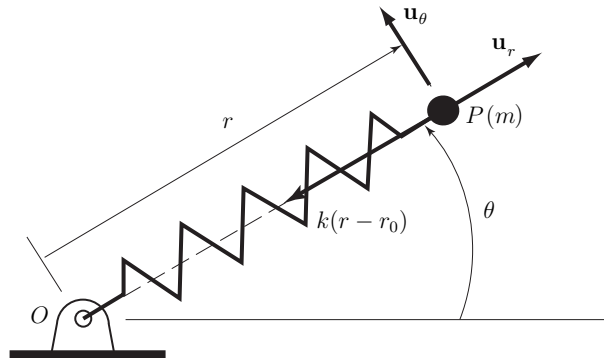

Fig. 2.8 Linear spring

$$\mathbf{F} = -k(r - r_0)\mathbf{u}_r,$$

where k is the spring constant, r_0 is the un-stretched length of the spring, and \mathbf{u}_r is the polar unit vector. Using the expression for the velocity in polar coordinates, the vector $d\mathbf{r} = \mathbf{v}dt$ is

$$d\mathbf{r} = \left(\frac{dr}{dt}\mathbf{u}_r + r\frac{d\theta}{dt}\mathbf{u}_\theta \right) dt = dr\mathbf{u}_r + r d\theta\mathbf{u}_\theta. \quad (2.25)$$

$$\mathbf{F} \cdot d\mathbf{r} = [-k(r - r_0)\mathbf{u}_r] \cdot (dr\mathbf{u}_r + r d\theta\mathbf{u}_\theta) = -k(r - r_0) dr.$$

One may express the work done by a spring in terms of its stretch, defined by $\delta = r - r_0$. In terms of this variable, $\mathbf{F} \cdot d\mathbf{r} = -k\delta d\delta$, and the work is

$$U_{12} = \int_{\mathbf{r}_1}^{\mathbf{r}_2} \mathbf{F} \cdot d\mathbf{r} = \int_{\delta_1}^{\delta_2} -k\delta d\delta = -\frac{1}{2}k(\delta_2^2 - \delta_1^2),$$

where δ_1 and δ_2 are the values of the stretch at the initial and final positions.

Work done on a particle by weight

The particle P of mass m , Fig. 2.9, moves from position 1 with coordinates (x_1, y_1, z_1) to position 2 with coordinates (x_2, y_2, z_2) in a cartesian reference frame with the y axis upward. The force exerted by the weight is

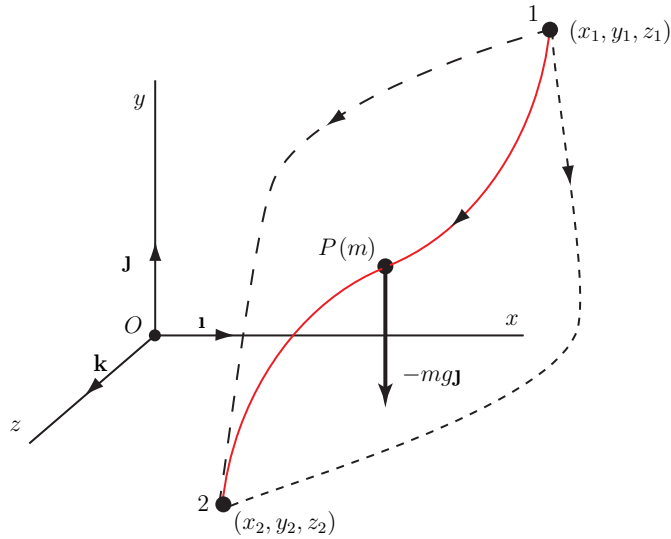

Fig. 2.9 Particle moving from position 1 to position 2

$$\mathbf{F} = -m g \mathbf{j}.$$

Because $\mathbf{v} = d\mathbf{r}/dt$, the expression for the vector $d\mathbf{r}$ is

$$d\mathbf{r} = \left(\frac{dx}{dt} \mathbf{i} + \frac{dy}{dt} \mathbf{j} + \frac{dz}{dt} \mathbf{k} \right) dt = dx \mathbf{i} + dy \mathbf{j} + dz \mathbf{k}.$$

The dot product of \mathbf{F} and $d\mathbf{r}$ is

$$\mathbf{F} \cdot d\mathbf{r} = (-mg \mathbf{j}) \cdot (dx \mathbf{i} + dy \mathbf{j} + dz \mathbf{k}) = -mg dy.$$

The work done as P moves from position 1 to position 2 is

$$U_{12} = \int_{\mathbf{r}_1}^{\mathbf{r}_2} \mathbf{F} \cdot d\mathbf{r} = \int_{y_1}^{y_2} -mg dy = -mg(y_2 - y_1).$$

The work is the product of the weight and the change in the height of the particle. The work done is negative if the height increases and positive if it decreases. The work done is the same no matter what path the particle follows from position 1 to position 2. To determine the work done by the weight of the particle only the relative heights of the initial and final positions must be known.

2.9 Conservation of Energy

The change in the kinetic energy is

$$U_{12} = \int_{r_1}^{r_2} \mathbf{F} \cdot d\mathbf{r} = \frac{1}{2}mv_2^2 - \frac{1}{2}mv_1^2. \quad (2.26)$$

A scalar function of position V called, *potential energy*, may be determined as

$$dV = -\mathbf{F} \cdot d\mathbf{r}. \quad (2.27)$$

Using the function V the integral defining the work is

$$U_{12} = \int_{r_1}^{r_2} \mathbf{F} \cdot d\mathbf{r} = \int_{V_1}^{V_2} -dV = -(V_2 - V_1), \quad (2.28)$$

where V_1 and V_2 are the values of V at the positions r_1 and r_2 . The principle of work and energy would then have the form

$$\frac{1}{2}mv_1^2 + V_1 = \frac{1}{2}mv_2^2 + V_2, \quad (2.29)$$

which means that the sum of the kinetic energy and the potential energy V is constant

$$\frac{1}{2}mv^2 + V = \text{constant}, \quad (2.30)$$

or

$$E = T + V = \text{constant}. \quad (2.31)$$

If a potential energy V exists for a given force \mathbf{F} , i.e., a function of position V exists such that $dV = -\mathbf{F} \cdot d\mathbf{r}$, then \mathbf{F} is said to be *conservative*.

If all the forces that do work on a system are conservative, the total energy - the sum of the kinetic energy and the potential energies of the forces - is constant, or conserved. The system is said to be conservative.

2.10 Conservative Forces

A particle moves from a position 1 to a position 2. Equation (2.28) states that the work depends only on the values of the potential energy at positions 1 and 2. The work done by a conservative force as a particle moves from position 1 to position 2 is independent of the path of the particle.

A particle P of mass m slides with friction along a path of length L . The magnitude of the friction force is μmg , and is opposite to the direction of the motion of the particle. The coefficient of friction is μ . The work done by the friction force is

$$U_{12} = \int_0^L -\mu mg \, ds = -\mu mgL.$$

The work is proportional to the length L of the path and therefore is not independent of the path of the particle. Friction forces are not conservative.

Potential energy of a force exerted by a spring

The force exerted by a linear spring attached to a fixed support is a conservative force.

In terms of polar coordinates, the force exerted on a particle, Fig. 2.8, by a linear spring is $\mathbf{F} = -k(r - r_0)\mathbf{u}_r$. The potential energy must satisfy

$$dV = -\mathbf{F} \cdot d\mathbf{r} = k(r - r_0) \, dr,$$

or

$$dV = k\delta \, d\delta,$$

where $\delta = r - r_0$ is the stretch of the spring. Integrating this equation, the potential energy of a linear spring is

$$V = \frac{1}{2}k\delta^2. \quad (2.32)$$

Potential energy of weight

The weight of a particle is a conservative force. The weight of the particle P of mass m , Fig. 2.9, is $F = -mg\mathbf{j}$. The potential energy V must satisfy the relation

$$dV = -\mathbf{F} \cdot d\mathbf{r} = (mg\mathbf{j}) \cdot (dx\mathbf{i} + dy\mathbf{j} + dz\mathbf{k}) = mg \, dy, \quad (2.33)$$

or

$$\frac{dV}{dy} = mg.$$

Integrating this equation, the potential energy is

$$V = mgy + C,$$

where C is an integration constant. The constant C is arbitrary, because this expression satisfies Eq. (2.33) for any value of C . For $C = 0$ the potential energy of the weight of a particle is

$$V = mgy. \quad (2.34)$$

The potential energy V is a function of position and may be expressed in terms of a cartesian reference frame as $V = V(x, y, z)$. The differential of dV is

$$dV = \frac{\partial V}{\partial x} dx + \frac{\partial V}{\partial y} dy + \frac{\partial V}{\partial z} dz. \quad (2.35)$$

The potential energy V satisfies the relation

$$\begin{aligned} dV &= -\mathbf{F} \cdot d\mathbf{r} = -(F_x\mathbf{i} + F_y\mathbf{j} + F_z\mathbf{k}) \cdot (dx\mathbf{i} + dy\mathbf{j} + dz\mathbf{k}) \\ &= -(F_x dx + F_y dy + F_z dz), \end{aligned} \quad (2.36)$$

where $\mathbf{F} = F_x\mathbf{i} + F_y\mathbf{j} + F_z\mathbf{k}$. Using Eq. (2.35) and Eq. (2.36), one may obtain

$$\frac{\partial V}{\partial x} dx + \frac{\partial V}{\partial y} dy + \frac{\partial V}{\partial z} dz = -(F_x dx + F_y dy + F_z dz),$$

which implies that

$$F_x = -\frac{\partial V}{\partial x}, F_y = -\frac{\partial V}{\partial y}, F_z = -\frac{\partial V}{\partial z}. \quad (2.37)$$

Given the potential energy $V = V(x, y, z)$ expressed in cartesian coordinates, the force \mathbf{F} is

$$\mathbf{F} = -\left(\frac{\partial V}{\partial x}\mathbf{i} + \frac{\partial V}{\partial y}\mathbf{j} + \frac{\partial V}{\partial z}\mathbf{k}\right) = -\nabla V, \quad (2.38)$$

where ∇V is the *gradient* of V . The gradient expressed in cartesian coordinates is

$$\nabla = \frac{\partial}{\partial x}\mathbf{i} + \frac{\partial}{\partial y}\mathbf{j} + \frac{\partial}{\partial z}\mathbf{k}. \quad (2.39)$$

The *curl* of a vector force \mathbf{F} in cartesian coordinates is

$$\nabla \times \mathbf{F} = \begin{vmatrix} \mathbf{i} & \mathbf{j} & \mathbf{k} \\ \frac{\partial}{\partial x} & \frac{\partial}{\partial y} & \frac{\partial}{\partial z} \\ F_x & F_y & F_z \end{vmatrix}. \quad (2.40)$$

If a force F is conservative, its curl $\nabla \times \mathbf{F}$ is zero. The converse is also true: A force \mathbf{F} is conservative if its curl is zero.

In terms of cylindrical coordinates the force \mathbf{F} is

$$\mathbf{F} = -\nabla V = -\left(\frac{\partial V}{\partial r}\mathbf{u}_r + \frac{1}{r}\frac{\partial V}{\partial \theta}\mathbf{u}_\theta + \frac{\partial V}{\partial z}\mathbf{k}\right). \quad (2.41)$$

In terms of cylindrical coordinates, the curl of the force \mathbf{F} is

$$\nabla \times \mathbf{F} = \frac{1}{r} \begin{vmatrix} \mathbf{u}_r & r\mathbf{u}_\theta & \mathbf{k} \\ \frac{\partial}{\partial r} & \frac{\partial}{\partial \theta} & \frac{\partial}{\partial z} \\ F_r & rF_\theta & F_z \end{vmatrix}. \quad (2.42)$$

2.11 Principle of Impulse and Momentum

Newton's second law

$$\mathbf{F} = m \frac{d\mathbf{v}}{dt},$$

is integrated with respect to time to obtain

$$\int_{t_1}^{t_2} \mathbf{F} dt = m\mathbf{v}_2 - m\mathbf{v}_1, \quad (2.43)$$

where \mathbf{v}_1 and \mathbf{v}_2 are the velocities of the particle P at the times t_1 and t_2 .

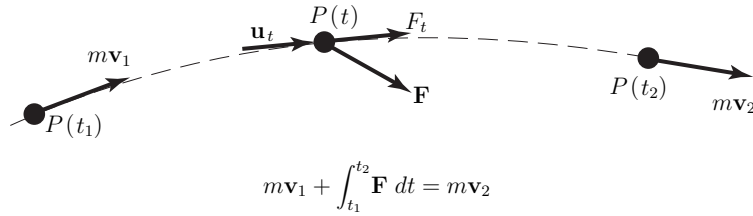

Fig. 2.10 Principle of impulse and momentum

The term $\int_{t_1}^{t_2} \mathbf{F} dt$ is called the *linear impulse*, and the term $m\mathbf{v}$ is called the *linear momentum*.

The principle of impulse and momentum: The impulse applied to a particle during an interval of time is equal to the change in its linear momentum, Fig. 2.10. The dimensions of the linear impulse and linear momentum are (mass) *times* (length)/(time).

The average with respect to time of the total force acting on a particle from t_1 to t_2 is

$$\mathbf{F}_{av} = \frac{1}{t_2 - t_1} \int_{t_1}^{t_2} \mathbf{F} dt,$$

so one may write Eq. (2.43) as

$$\mathbf{F}_{av}(t_2 - t_1) = m\mathbf{v}_2 - m\mathbf{v}_1. \quad (2.44)$$

An *impulsive force* is a force of relatively large magnitude that acts over a small interval of time, Fig. 2.11. Equations (2.43) and (2.44) may be expressed in scalar

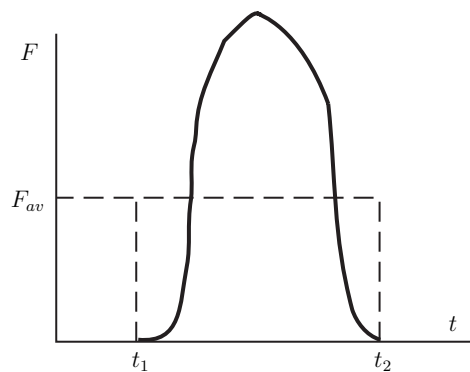

Fig. 2.11 Impulsive force

forms. The sum of the forces in the tangent direction τ to the path of the particle equals the product of its mass m and the rate of change of its velocity along the path

$$F_t = ma_t = m \frac{dv}{dt}.$$

Integrating this equation with respect to time, one may obtain

$$\int_{t_1}^{t_2} F_t dt = mv_2 - mv_1, \quad (2.45)$$

where v_1 and v_2 are the velocities along the path at the times t_1 and t_2 . The impulse applied to an object by the sum of the forces tangent to its path during an interval of time is equal to the change in its linear momentum along the path.

2.12 Conservation of Linear Momentum

Consider two particles P_1 of mass m_1 and P_2 of mass m_2 in Fig. 2.12. The vector \mathbf{F}_{12} is the force exerted by P_1 on P_2 , and \mathbf{F}_{21} is the force exerted by P_2 on P_1 . These forces could be contact forces or could be exerted by a spring connecting the particles. As a consequence of Newton's third law, these forces are equal and opposite

$$\mathbf{F}_{12} + \mathbf{F}_{21} = \mathbf{0}. \quad (2.46)$$

Consider that no external forces act on P_1 and P_2 , or the external forces are negligible. The principle of impulse and momentum to each particle for arbitrary times t_1 and t_2 gives

$$\int_{t_1}^{t_2} \mathbf{F}_{21} dt = m_1 \mathbf{v}_{P_1}(t_2) - m_1 \mathbf{v}_{P_1}(t_1),$$

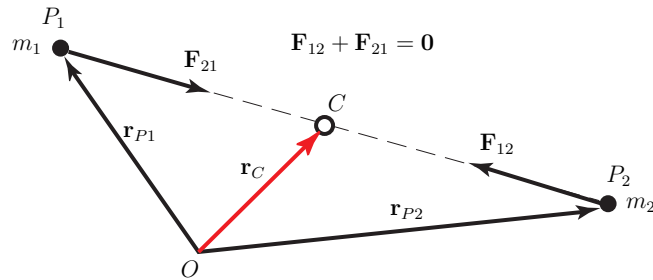

Fig. 2.12 Position of the center of mass of P_1 and P_2

$$\int_{t_1}^{t_2} \mathbf{F}_{12} dt = m_2 \mathbf{v}_{P_2}(t_2) - m_1 \mathbf{v}_{P_2}(t_1),$$

where $\mathbf{v}_{P_1}(t_1)$, $\mathbf{v}_{P_1}(t_2)$ are the velocities of P_1 at the times t_1 , t_2 , and $\mathbf{v}_{P_2}(t_1)$, $\mathbf{v}_{P_2}(t_2)$ are the velocities of P_2 at the times t_1 , t_2 . The sum of these equations is

$$m_1 \mathbf{v}_{P_1}(t_1) + m_2 \mathbf{v}_{P_2}(t_1) = m_1 \mathbf{v}_{P_1}(t_2) + m_2 \mathbf{v}_{P_2}(t_2),$$

or the total linear momentum of P_1 and P_2 is conserved

$$m_1 \mathbf{v}_{P_1} + m_2 \mathbf{v}_{P_2} = \text{constant.} \quad (2.47)$$

The position of the center of mass of P_1 and P_2 is, Fig. 2.12

$$\mathbf{r}_C = \frac{m_1 \mathbf{r}_{P_1} + m_2 \mathbf{r}_{P_2}}{m_1 + m_2},$$

where \mathbf{r}_{P_1} and \mathbf{r}_{P_2} are the position vectors of P_1 and P_2 . Taking the time derivative of this equation and using Eq. (2.47) one may obtain

$$(m_1 + m_2) \mathbf{v}_C = m_1 \mathbf{v}_{P_1} + m_2 \mathbf{v}_{P_2} = \text{constant}, \quad (2.48)$$

where $\mathbf{v}_C = d\mathbf{r}_C/dt$ is the velocity of the combined center of mass. The total linear momentum of the particles is conserved and the velocity of the combined center of mass of the particles P_1 and P_2 is constant.

2.13 Principle of Angular Impulse and Momentum

The position of a particle P of mass m relative to an inertial reference frame with origin O is given by the position vector $\mathbf{r} = \mathbf{r}_{OP}$, Fig. 2.13. The cross product of

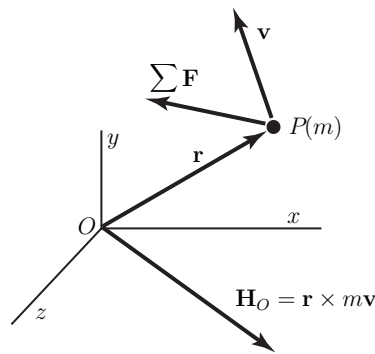

Fig. 2.13 Angular momentum

Newton's second law with the position vector \mathbf{r} is

$$\mathbf{r} \times \mathbf{F} = \mathbf{r} \times m\mathbf{a} = \mathbf{r} \times m \frac{d\mathbf{v}}{dt}. \quad (2.49)$$

The time derivative of the quantity $\mathbf{r} \times m\mathbf{v}$ is

$$\frac{d}{dt}(\mathbf{r} \times m\mathbf{v}) = \left(\frac{d\mathbf{r}}{dt} \times m\mathbf{v} \right) + \left(\mathbf{r} \times m \frac{d\mathbf{v}}{dt} \right) = \mathbf{r} \times m \frac{d\mathbf{v}}{dt},$$

because $\frac{d\mathbf{r}}{dt} = \mathbf{v}$, and the cross product of parallel vectors is zero. Equation (2.49) may be written as

$$\mathbf{r} \times \mathbf{F} = \frac{d\mathbf{H}_O}{dt}, \quad (2.50)$$

where the vector

$$\mathbf{H}_O = \mathbf{r} \times m\mathbf{v} \quad (2.51)$$

is called the *angular momentum* about O Fig. 2.13. The angular momentum may be interpreted as the moment of the linear momentum of the particle about point O . The moment $\mathbf{r} \times \mathbf{F}$ equals the rate of change of the moment of momentum about point O .

Integrating Eq. (2.50) with respect to time, one may obtain

$$\int_{t_1}^{t_2} (\mathbf{r} \times \mathbf{F}) dt = (\mathbf{H}_O)_2 - (\mathbf{H}_O)_1. \quad (2.52)$$

The integral on the left hand side is called the *angular impulse*.

The principle of angular impulse and momentum: The angular impulse applied to a particle during an interval of time is equal to the change in its angular momentum.

The dimensions of the angular impulse and angular momentum are $(\text{mass}) \times (\text{length})^2 / (\text{time})$.

2.14 Examples

Example 2.1

A particle M of mass m starts moving from the origin O on the inclined plane A . The angle of the inclined plane A with the horizontal line BD is α , $\alpha = \angle(AB, CB)$.

The reference frame at O has the axis Ox parallel to CB ($Ox \parallel CB$) and the vertical axis Oz perpendicular to the inclined plane. The axis Oy is and perpendicular to Ox and it is situated in the plane A . The initial velocity of the particle is $\mathbf{v}_0 = v_0 \mathbf{J}$ where \mathbf{J} is the unit vector of the Oy axis. The incline plane A , the associated reference frame $Oxyz$ and the motion of the sphere are shown in Fig. E???.1.

Find the equations of motion of the particle.

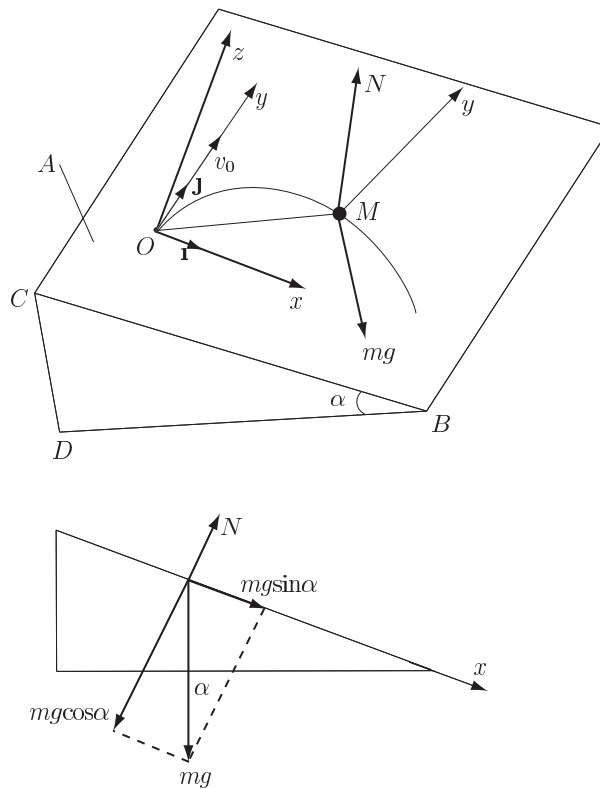

Fig. E2.1 Example 2.1

Solution

The equations of the motion with respect to the reference frame $Oxyz$ is

$$m\ddot{x} = mg \sin \alpha, \quad (2.53)$$

$$m\dot{y} = 0, \quad (2.54)$$

$$m\ddot{z} = N - mg \cos \alpha. \quad (2.55)$$

Because the motion of the particle is planar and Oz is perpendicular to the plane of the motion it results

$$z = 0 \text{ and } \ddot{z} = 0,$$

From Eq. (2.55) the reaction is

$$N = mg \cos \alpha.$$

Integrating the Eqs.(2.53) and (2.54) one can write

$$\begin{aligned} x &= C_1 + C_2 t + \frac{t^2}{2} g \sin \alpha, \\ y &= C_3 + C_4 t. \end{aligned} \quad (2.56)$$

Using the initial conditions at $t = 0$

$$x = 0, \quad y = 0, \quad \dot{x} = 0, \quad \dot{y} = v_0,$$

the constants are

$$C_1 = C_2 = C_3 = 0 \text{ and } C_4 = v_0. \quad (2.57)$$

Thus, from Eqs.(2.56) and (2.57) it results

$$\begin{aligned} x &= \frac{t^2}{2} g \sin \alpha, \\ y &= v_0 t. \end{aligned} \quad (2.58)$$

Using Eq.(2.58), the trajectory of the particle can be written as

$$x = \frac{1}{2} \frac{g \sin \alpha}{v_0^2} y^2.$$

For $\alpha = 0$ one can write

$$N = mg, \quad x = 0, \quad y = v_0 t. \quad (2.59)$$

Example 2.2

The spring shown in Fig. E???.2, has the initial length OO_1 . The spring can be stretched with the distance $OM = x$, and the spring force will be $F = kOM$, where k is the elastic spring constant.

Find the potential energy and the total work done when the particle M moves from point A ($OA = x_A$) to point B ($OB = x_B$).

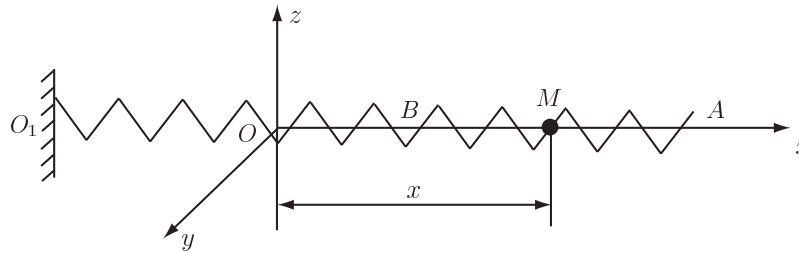

Fig. E2.2 Example 2.2

Solution

For the reference frame shown in Fig. E???.2 the force acting on the particle M is

$$\mathbf{F} = F_x \mathbf{i} + F_y \mathbf{j} + F_z \mathbf{k}$$

where $F_x = F$.

It results

$$F_x = -kx, \quad F_y = 0, \quad F_z = 0.$$

Using Eq. (2.36) one can calculate the potential energy

$$V = \frac{1}{2} kx^2 + C,$$

and the work is

$$U_{AB} = -(V_B - V_A) = \frac{1}{2} k(x_A^2 - x_B^2).$$

Example 2.3

A particle P of mass m is located at the distance $\mathbf{r} = \mathbf{r}_{OP} = x\mathbf{i} + y\mathbf{j} + z\mathbf{k}$, from the origin of a fixed reference frame $Oxyz$ as shown in Fig. E2.3. The mass of the origin O is M . The force between P and O is $F = G\frac{mM}{r^2}$, where G is called the universal gravitational constant.

Find the potential energy and the total work done when the particle M moves from point A ($OA = x_A$) to point B ($OB = x_B$).

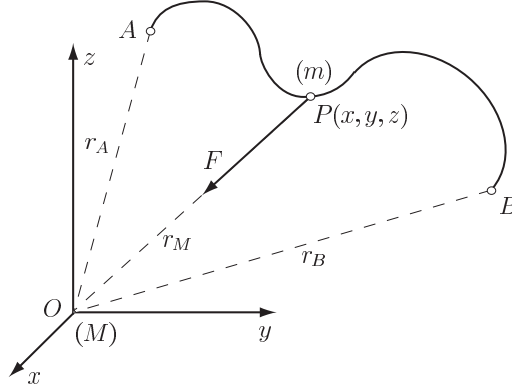

Fig. E2.3 Example 2.3

Solution

With respect to the reference frame $Oxyz$ the force \mathbf{F} is

$$\mathbf{F} = F_x\mathbf{i} + F_y\mathbf{j} + F_z\mathbf{k}$$

where

$$F_x = -k\frac{mM}{r^2}\frac{x}{r}, \quad F_y = -k\frac{mM}{r^2}\frac{y}{r}, \quad F_z = -k\frac{mM}{r^2}\frac{z}{r}.$$

The distance $r = |\mathbf{r}|$ is computed as

$$r = \sqrt{x^2 + y^2 + z^2}.$$

Using Eq. (2.36) the potential energy U is calculated as

$$U = G\frac{mM}{r} = G\frac{mM}{\sqrt{x^2 + y^2 + z^2}}.$$

The total work done when the particle M moves from point A ($OA = x_A$) to point B ($OB = x_B$) is given by

$$L_{A-B} = U_B - U_A = GmM \left(\frac{1}{r_B} - \frac{1}{r_A} \right).$$

Example 2.4

A heavy body falls on the ground without initial velocity. The reference frame Oxy and the initial and final position of the body are shown in Fig. E???.4. The coordinates of the body are $A(h, 0)$, where $AB = h$ represents the distance between the body and the ground. The coordinates of the final position B of the body are $B(0, 0)$.

Find the velocity of the body, when the body hits the ground (the body hits the ground at point B).

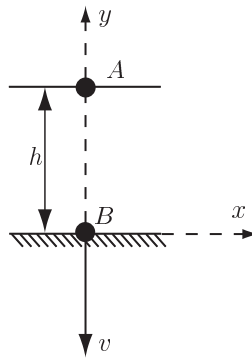

Fig. E2.4 Example 2.4

Solution

The kinetic energy at A ($v = 0$) is

$$T_A = 0, \quad (2.60)$$

and the kinetic energy at B is

$$T_B = \frac{1}{2}mv^2, \quad (2.61)$$

where v is the velocity of the body at the point B .

The work between A and B is

$$L_{A-B} = mgh. \quad (2.62)$$

From Eqs.(2.60), (2.61) and (2.62) it results

$$\frac{1}{2}mv^2 = mgh,$$

or

$$v = \sqrt{2gh}.$$

Example 2.5

The system shown in the Fig. E???.5 is initially at rest. The system consists of two pulley wheels, one with the radius r and the other with radius R ($r < R$), and two bodies 1 and 2. The weight of body 1 is P and the weight of body 2 is Q .

Determine the motion of the system when it is released from rest.

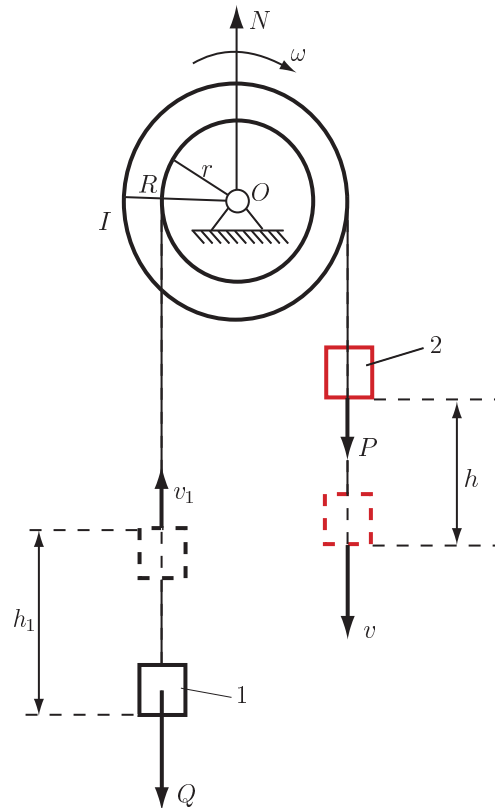

Fig. E2.5 Example 2.5

Solution

Suppose that after a period of time t , the body 1 moves downward with a distance h . The pulley wheels will rotate with an angle $\theta = \frac{h}{R}$. The body 2 moves upward with a distance $h_1 = \theta r = h \frac{r}{R}$.

If the velocity of the body 1 is v , the angular velocity of the pulley wheels is $\omega = \frac{v}{R}$, and the velocity of the body 2 is $v_1 = v \frac{r}{R}$.

The kinetic energy of the system is the sum of the kinetic energies of the bodies. One can write kinetic energy at t as

$$T = T(t) = \frac{1}{2} \frac{P}{g} v^2 + \frac{1}{2} I \omega^2 + \frac{1}{2} \frac{Q}{g} v_1^2,$$

or

$$T = \frac{1}{2} \frac{P}{g} v^2 + \frac{1}{2} I \frac{v^2}{R^2} + \frac{1}{2} \frac{Q}{g} v^2 \frac{r^2}{R^2} = \frac{v^2}{2} \left(\frac{P}{g} + \frac{I}{R^2} + \frac{Qr^2}{gR^2} \right).$$

where g is the gravitational acceleration, and I is the mass moment of inertia of the system of the two pulley wheels with respect to the rotational axis.

The total work is

$$L_{A-B} = Ph - Qh_1 = h \left(P - Q \frac{r}{R} \right).$$

where A is the initial position of the system and B is the position at the time t .

Using the relation $L_{A-B} = T_B - T_A$ one can write

$$\frac{v^2}{2} \left(\frac{P}{g} + \frac{I}{R^2} + \frac{Qr^2}{gR^2} \right) = h \left(P - Q \frac{r}{R} \right),$$

or

$$v^2 = \frac{2h \left(P - Q \frac{r}{R} \right)}{\frac{P}{g} + \frac{I}{R^2} + \frac{Qr^2}{gR^2}}.$$

The derivative with respect to time is

$$2v\dot{v} = \frac{2\dot{h} \left(P - Q \frac{r}{R} \right)}{\frac{P}{g} + \frac{I}{R^2} + \frac{Qr^2}{gR^2}}.$$

Using the relations

$$\dot{h} = v \text{ and } \dot{v} = a,$$

where a is the acceleration of the body 1, one can determine

$$a = \frac{P - Q \frac{r}{R}}{\frac{P}{g} + \frac{I}{R^2} + \frac{Qr^2}{gR^2}} = \text{const.}$$

Thus

$$h = \frac{1}{2} at^2, \quad \theta = \frac{a}{2R} t^2, \quad h_1 = \frac{ar}{2R} t^2,$$

and

$$v = at, \quad \omega = \frac{at}{R}, \quad v_1 = \frac{ar}{R} t.$$

Example 2.6

An horizontal disk is rotating without friction about its vertical axis as shown in Fig. E???.6 . The vertical axis is perpendicular to the disk and intersects the disk at the center O . The angular velocity of the disk is ω . At the distance r from the center of the disk is placed a particle M ($OM = r$). The mass of the particle M is m . The absolute velocity of the particle M is v , and the trajectory of the particle is a circle.

Find the relative velocity between the particle and the disk.

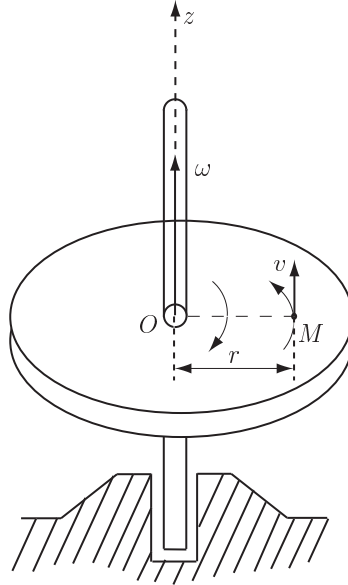

Fig. E2.6 Example 2.6

Solution

The moment of the external forces on the system disk-particle (weight of the particle and the reaction at rotational axis) is zero

$$\mathbf{M}_0 = \mathbf{0}.$$

The angular momentum of the particle and the disk about O is

$$\mathbf{H}_0 = \mathbf{r} \times m\mathbf{v} + I_z\boldsymbol{\omega},$$

or

$$H_0 = mrv + I_z\omega,$$

where ω is the angular velocity of the disk and I_z is the mass moment of inertia. The derivative of the angular momentum is

$$\dot{H}_0 = \dot{M}_0 = 0,$$

or

$$H_0 = mrv + I_z \omega = c = \text{const.} \quad (2.63)$$

Because the body is initially at rest $c = 0$. Thus, from Eq.(2.63) it results

$$\omega = -\frac{mr}{I_z}v.$$

The relative velocity of the body with respect to the disk is given by

$$v_r = v - \omega r = v + \frac{mr}{I_z}vr = \frac{mr^2 + I_z}{I_z}v.$$

Example 2.7

A person of mass m_p stands at the center of a stationary wagon of mass m_w . The length of the wagon is L , as shown in Fig. E???.7(a).

1. The person starts moving with the velocity v_p relative to the ground. Determine the velocity of the wagon relative to the ground.

2. The person stops when he reaches the end of the wagon. Determine the positions of the person and wagon relative to their original position.

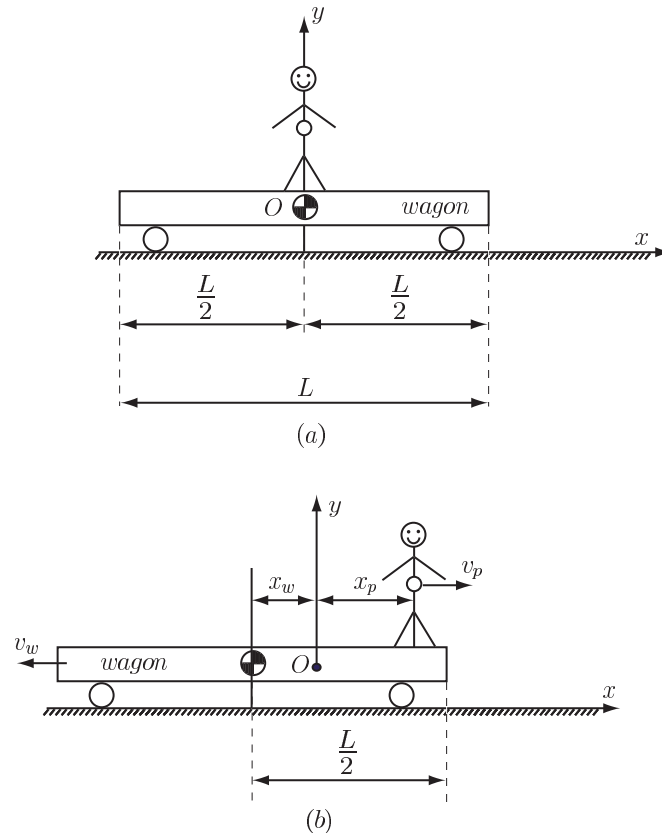

Fig. E2.7 Example 2.7

Solution

1. Let v_w be the velocity of the wagon. If the person moves to the right then $v_p > 0$ and $v_w < 0$ [Fig. E???.7(b)]. The origin of the coordinate system is at the center of the stationary wagon [Fig. E???.7(a)].

Before the person starts moving, the total linear momentum of the person and the wagon is zero because the person and wagon are stationary. When the person is moving, the total linear momentum of the person and the wagon in the horizontal direction is $m_p v_p - m_w v_w$. The total linear momentum in the horizontal direction is

conserved and one can obtain

$$m_p v_p - m_w v_w = 0. \quad (2.64)$$

The velocity of the wagon is

$$v_w = \frac{m_p v_p}{m_w}. \quad (2.65)$$

2. Let x_p be the position of the person relative to the origin O [Fig. E???.7(b)]. The position of the mass center of the wagon with respect to the origin is x_w . The position of the combined center of mass of the person and the wagon is

$$x_c = \frac{m_p x_p - m_w x_w}{m_p + m_w}.$$

The combined center of mass is initially stationary, and it must remain stationary. When the person has stopped at the end of the wagon the combined center of mass must still be at $x = 0$ (the original stationary position).

Thus

$$\frac{m_p x_p - m_w x_w}{m_p + m_w} = 0. \quad (2.66)$$

Another equation is the relation

$$x_p + x_w = \frac{L}{2}. \quad (2.67)$$

Solving together Eqs.(2.66) and (2.67) one can obtain

$$x_p = \frac{m_w L}{2(m_p + m_w)}, \quad x_w = \frac{m_p L}{2(m_p + m_w)}.$$

Example 2.8

A particle of mass m attached by a string of length r to a fixed point O , is rotating in a horizontal circle about a vertical axis Oz . This pendulum (conical pendulum) describes a cone of constant angle 2α as shown in Fig. E2.8. Determine the tangential velocity $\dot{\theta}$.

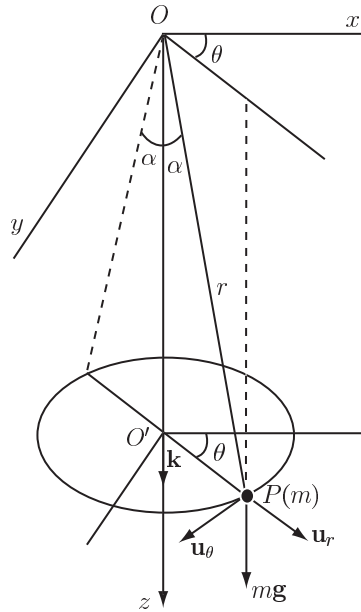

Fig. E2.8 Example 2.8

Solution

The position vector of the particle is

$$\mathbf{r}_{OP} = \mathbf{r} = r \sin \alpha \mathbf{u}_r + r \cos \alpha \mathbf{k},$$

where $\alpha = \text{constant}$ and $r = \text{constant}$.

The velocity of the particle P is

$$\mathbf{v} = \dot{\mathbf{r}} = r \sin \alpha \dot{\mathbf{u}}_r + r \cos \alpha \dot{\mathbf{k}}.$$

The derivative of the polar unit vector is $\dot{\mathbf{u}}_r = \dot{\theta} \mathbf{u}_\theta$ and $\dot{\mathbf{k}} = 0$.

Thus

$$\mathbf{v} = r \dot{\theta} \sin \alpha \mathbf{u}_\theta.$$

The moment of external forces about the origin O is

$$\begin{aligned} \mathbf{M}_O &= \mathbf{r} \times m \mathbf{g} = \mathbf{r} \times m g \mathbf{k} = (r \sin \alpha \mathbf{u}_r + r \cos \alpha \mathbf{k}) \times m g \mathbf{k} \\ &= r m g \sin \alpha (\mathbf{u}_r \times \mathbf{k}) = -r m g \sin \alpha \mathbf{u}_\theta. \end{aligned}$$

The angular momentum of the particle about O is the momentum of the linear momentum

$$\begin{aligned}\mathbf{H}_O &= \mathbf{r} \times m\mathbf{v} = (r \sin \alpha \mathbf{u}_r + r \cos \alpha \mathbf{k}) \times mr\dot{\theta} \sin \alpha \mathbf{u}_\theta \\ &= -mr^2 \dot{\theta} \sin \alpha \cos \alpha \mathbf{u}_r + mr^2 \dot{\theta} \sin^2 \alpha \mathbf{k}.\end{aligned}$$

The derivative of the angular momentum is

$$\dot{\mathbf{H}}_O = \frac{d\mathbf{H}_O}{dt} = -mr^2 \ddot{\theta} \sin \alpha \cos \alpha \mathbf{u}_r - mr^2 \dot{\theta}^2 \sin \alpha \cos \alpha \mathbf{u}_\theta + mr^2 \ddot{\theta} \sin^2 \alpha \mathbf{k}.$$

The moment of all the external forces acting on a particle about the fixed origin O is equal to the time rate of change of the angular momentum of the particle

$$\mathbf{M}_O = \dot{\mathbf{H}}_O,$$

or

$$\begin{cases} mr^2 \ddot{\theta} \sin \alpha \cos \alpha = 0 \\ mr^2 \dot{\theta}^2 \sin \alpha \cos \alpha = mgr \sin \alpha \\ mr^2 \ddot{\theta} \sin^2 \alpha = 0. \end{cases}$$

The first equation of the previous system gives $\ddot{\theta} = 0$ and $\dot{\theta} = \text{constant}$. The tangential angular velocity $\dot{\theta}$ has a constant magnitude. Consider now $\dot{\theta} = \omega = \text{constant}$. With $\dot{\theta} = \omega$ the second equation of the system gives $mr^2 \omega^2 \sin \alpha \cos \alpha = mgr \sin \alpha$

or $\omega = \sqrt{\frac{g}{r \cos \alpha}}$.

Example 2.9

A particle P of mass m is travelling down an inclined surface as shown in Fig. E2.9(a). The particle P is released from rest of the point A .

The angle between the inclined surface and the horizontal is α , and the point A is located at the vertical distance h . The coefficient of friction between the particle and the surface is μ .

1. Find the velocity of the particle at the point B where the inclined surface intersects the horizontal.

2. The particle will stop, because of the friction, at the point C located at the distance d from the point B . Find the distance d .

Numerical application: $\alpha = 30^\circ$, $h = 2$ m, $\mu = 0.02$, $g = 9.8$ m/s².

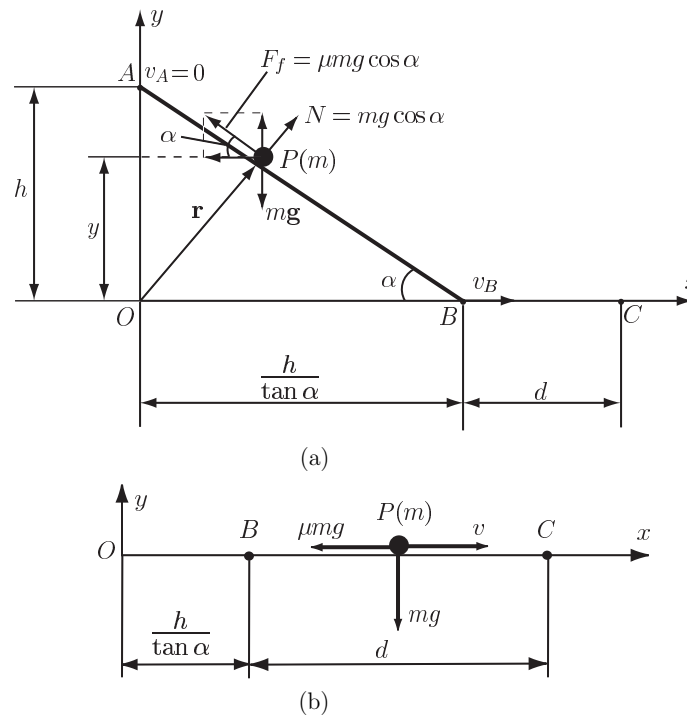

Fig. E2.9 Example 2.9

Solution

1. A system of coordinates axes is chosen as shown in Fig. E2.9(a). The gravity force acts on the particle and is given by

$$\mathbf{G} = m\mathbf{g} = -mg\mathbf{j}.$$

The friction force on the particle is

$$\mathbf{F}_f = -\mu m g \cos^2 \alpha \mathbf{i} + \mu m g \sin \alpha \cos \alpha \mathbf{j}.$$

The position vector of the particle P is

$$\mathbf{r} = \mathbf{r}_{OP} = x\mathbf{i} + y\mathbf{j}.$$

The work done on the particle as it moves between the points A and B is

$$\begin{aligned} U_{AB} &= \int_{\mathbf{r}_A}^{\mathbf{r}_B} \mathbf{F} \cdot d\mathbf{r} = \int_{\mathbf{r}_A}^{\mathbf{r}_B} (\mathbf{G} + \mathbf{F}_f) \cdot (dx\mathbf{i} + dy\mathbf{j}) \\ &= \int_{\mathbf{r}_A}^{\mathbf{r}_B} [-\mu m g \cos^2 \alpha \mathbf{i} + m g (\mu \sin \alpha \cos \alpha - 1) \mathbf{j}] \cdot (dx\mathbf{i} + dy\mathbf{j}) \\ &= \int_{\mathbf{r}_A}^{\mathbf{r}_B} -\mu m g \cos^2 \alpha dx + m g (\mu \sin \alpha \cos \alpha - 1) dy \\ &= \int_O^{OB=h/\tan \alpha} [-\mu m g \cos^2 \alpha] dx + \int_h^O m g (\mu \sin \alpha \cos \alpha - 1) dy \\ &= -\mu m g \cos^2 \alpha \left(\frac{h}{\tan \alpha} \right) - m g (\mu \sin \alpha \cos \alpha - 1) h \\ &= -\mu m g h \frac{\cos^3 \alpha}{\sin \alpha} - m g \mu h \sin \alpha \cos \alpha + m g h \\ &= m g h \left(1 - \frac{\mu \cos \alpha}{\sin \alpha} \right). \end{aligned}$$

The change in kinetic energy between the two positions A and B is

$$\Delta T_{AB} = T_B - T_A = \frac{1}{2} m v_B^2 - \frac{1}{2} m v_A^2 = \frac{1}{2} m v_B^2.$$

The particle starts from rest, i.e., $v_A = 0$. The principle of work and energy may be expressed as

$$U_{AB} = T_B - T_A,$$

or

$$m g h \left(1 - \frac{\mu \cos \alpha}{\sin \alpha} \right) = \frac{1}{2} m v_B^2.$$

The velocity of the particle at B is

$$v_B = \sqrt{2 g h \left(1 - \frac{\mu}{\tan \alpha} \right)}.$$

2. The work done on the particle as it moves between B and C is shown in Fig. E???.9(b) and can be expressed as

$$U_{BC} = \int_{\mathbf{r}_B}^{\mathbf{r}_C} \mathbf{F} \cdot d\mathbf{r} = \int_{\mathbf{r}_B}^{\mathbf{r}_C} (\mathbf{G} + \mathbf{F}_f) \cdot (dx\mathbf{i} + dy\mathbf{j})$$

$$= \int_{x_B}^{y_B} (-\mu m g \mathbf{i} - m g \mathbf{j}) \cdot d\mathbf{x} = \int_{\frac{h}{\tan \alpha}}^{\frac{h}{\tan \alpha} + d} (-\mu m g) dx = -\mu m g d.$$

The change in the kinetic energy of the particle as it moves from B to C is

$$\Delta T_{BC} = T_C - T_B = \frac{1}{2} m v_C^2 - \frac{1}{2} m v_B^2 = \frac{1}{2} m v_C^2 = -m g h \left(1 - \frac{\mu}{\sin \alpha}\right).$$

The principle of work and energy may be expressed as

$$U_{BC} = T_C - T_B,$$

or

$$-\mu m g d = -m g h \left(1 - \frac{\mu}{\sin \alpha}\right).$$

The distance d until the particle will stop is

$$d = \frac{h}{\mu} \left(1 - \frac{\mu}{\sin \alpha}\right).$$

Numerical application:

$$d = \frac{h}{\mu} \left(1 - \frac{\mu}{\sin \alpha}\right) = \frac{2}{0.02} \left(1 - \frac{0.02}{\sin 30^\circ}\right) = 96.54 \text{ m},$$

$$v_B = \sqrt{2 g h \left(1 - \frac{\mu}{\sin \alpha}\right)} = \sqrt{2 g \mu d} = \sqrt{2 (9.8) (0.02) (96.54)} = 6.152 \text{ m/s}.$$

Example 2.10

The ball of mass m is fired up the smooth vertical and circular track using the spring plunger (Fig. E2.10). The ball is of negligible size. The uncompressed position of the spring is at A_0 . The compression in the spring is $x_0 = A_0A$. The ball will begin to leave the track when $\theta = 90^\circ$ at the highest point B . The radius of the circular track is r and the height of the vertical track is h .

Determine the spring constant k .

Numerical application: $h = 0.4$ m, $r = 0.2$ m, $x_0 = 0.08$ m.

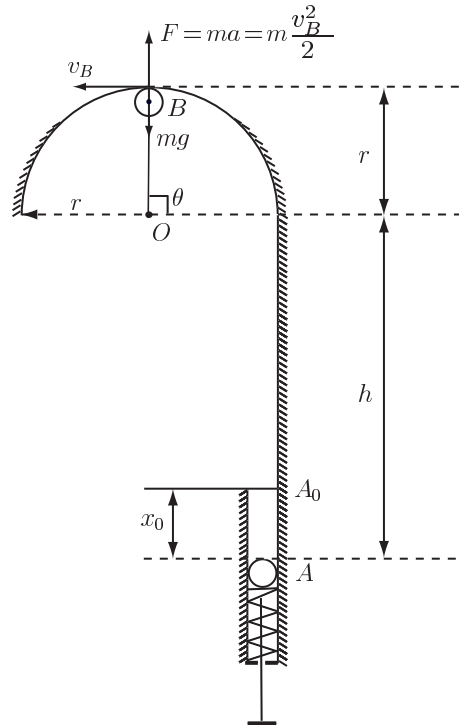

Fig. E2.10 Example 2.10

Solution

The total energy (the sum of the kinetic energy T , and the potential energy V) is constant or conserved at the positions A and B

$$T_A + V_A = T_B + V_B. \quad (2.68)$$

At the position A the kinetic energy is zero $T_A = 0$ ($v_A = 0$) and the potential energy is $V_A = \frac{1}{2} k x_0^2$. At the position B the kinetic energy is zero $T_B = \frac{1}{2} m v_B^2$ and the potential energy is $V_B = \frac{1}{2} k x_0^2$.

At B the free-body diagram of the ball is shown in Fig. E???.10. The equation of motion in the normal direction gives

$$m g = m \frac{v_B^2}{r},$$

or

$$v_B^2 = r g.$$

Equation (2.68) becomes

$$\frac{1}{2} k x_0^2 = \frac{1}{2} m r g + m g (h + r).$$

Solving one can have

$$k = \frac{m g}{x_0^2} (2h + 3r).$$

For the numerical application the spring constant is $k \simeq 5.5 \text{ N/cm}$.

2.15 Problems

Problem 2.1

A bullet with the mass m was fired horizontally into a spherical object with the mass M suspended on a wire with the length l as shown in Fig. P???.1. The spherical object with the bullet embedded in it moves to a height equal to h . Find the speed of the bullet as it entered the spherical object.

Numerical application: $m=50$ g, $M=40$ kg, $l=800$ mm, $h=25$ mm.

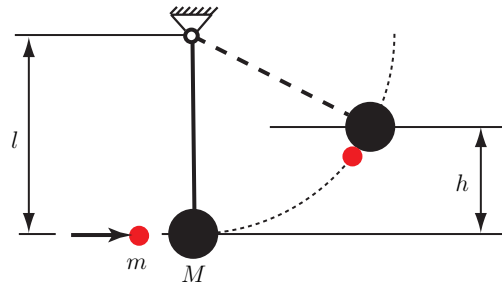

Fig. P2.1 Problem 2.1

Problem 2.2

Figure P???.2 shows two masses m_1 and m_2 , on a smooth horizontal plane, connected by a spring with the normal length l_0 . The spring constant is k . The spring is compressed to a length l ($l < l_0$) and the system is released. Find the speed of each mass when the spring is again its normal length l_0 .

Numerical application: $m_1=1$ kg, $m_2=2$ kg, $k=10$ lb/in., $l_0=12$ cm, $l=8$ cm.

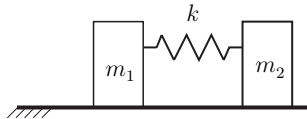

Fig. P2.2 Problem 2.2

Problem 2.3

A particle of mass m moves in a circular path of radius r on a smooth horizontal plane as shown in Fig. P???.3. The particle is connected to a string which passes through a the center O of the pane. The angular velocity of the string and the particle is ω when the radius is r . The string is pulled from underneath until the radius of the path is $r/3$. Find the final angular velocity and the final tension in the string.

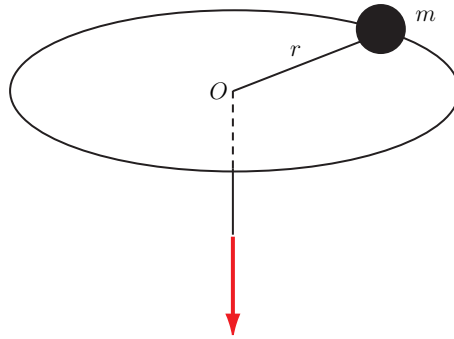

Fig. P2.3 Problem 2.3

Problem 2.4

Two particles, each weighing W , are connected by a string with negligible mass as shown in Fig. P2.4. The platform disk has the moment of inertia I_O and is rotating with the angular velocity ω when the string breaks. There is no friction between the particles, and the groove in which they ride. Find the angular speed of the system when the particles hit the outer stops.

Numerical application: $W=3$ lb, $\omega=30$ rad/s, $I_O=0.5$ slug-fe., $r=3$ in., $a=9$ in.

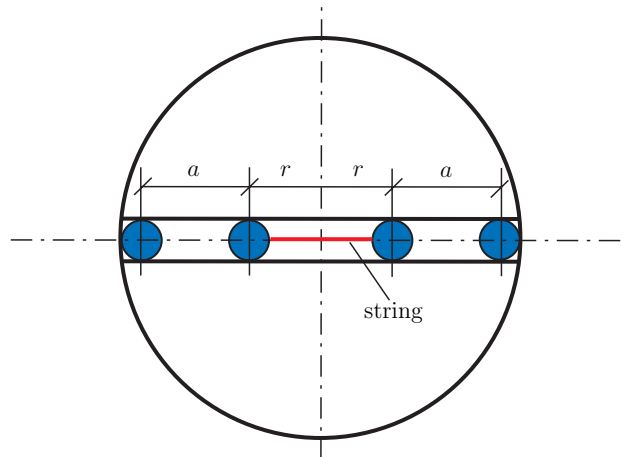

Fig. P2.4 Problem 2.4

Problem 2.5

The mass of a gun is m_g and the mass of the projectile is m_p . The speed of the projectile immediately after the explosion is v_g . Find the speed of recoil (the speed

of the gun immediately after the explosion).

Problem 2.6

A person with the mass m sitting in a boat with the mass M fires horizontally a shotgun releasing a bullet with the mass m_b . The muzzle speed is v_b and the friction is neglected. Find the speed of the boat after the shot is fired.

Problem 2.7

A bullet with the mass m_b is moving with a speed of v_b strikes an object of mass M moving in the same direction with a speed of V . After the impact the bullet is embedded in the block. Find the resultant speed of the bullet and the block immediately after the impact.

Numerical application: $m_b=40$ g, $v_b=450$ m/s, $M=10$ kg, $V=50$ m/s.

Problem 2.8

A sphere of mass m falls from a height h on a vertical spring makes contact with the spring as shown in Fig. P???.8. The spring with the elastic constant k compresses under the weight of the sphere. Find: 1) the total time of contact of the sphere with the spring; 2) the relative displacement of the spring; 3) the velocity jump of the sphere (before the contact and after the contact with the spring); 4) the maximum elastic force. Verify your results with the results obtained from a computer program.

Numerical application: $m=10$ kg, $h=1$ m, $k=294 \times 10^3$ N/m.

Results

$t_2=0.0184728$ s, $|\lambda|=0.0261689$ m, $\Delta v=8.85889$ m/s, $P_{max}=7693.65$ N.

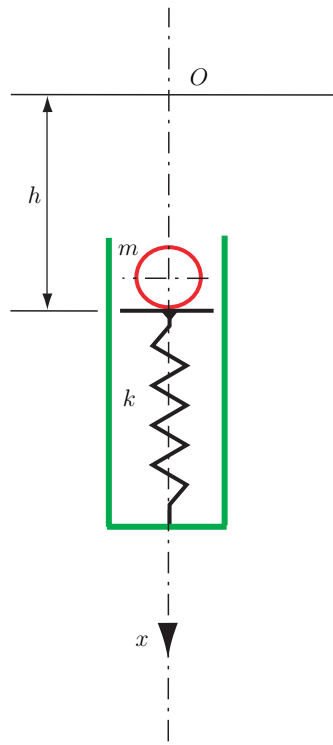
**Fig. P2.8** Problem 2.8