

MECH 3140
Homework #8

From Palm (Chapter 10)

Problems 1, 5, 12-13, 20-25

1 A control law has the following TF:

$$\frac{V(s)}{e(s)} = K_p + K_d s$$

The control input (u (volts)) is sent to a hydraulic actuator with a DC gain of K_1 (N/vole) and a time constant of τ . The hydraulic actuator is then applied to the following system:

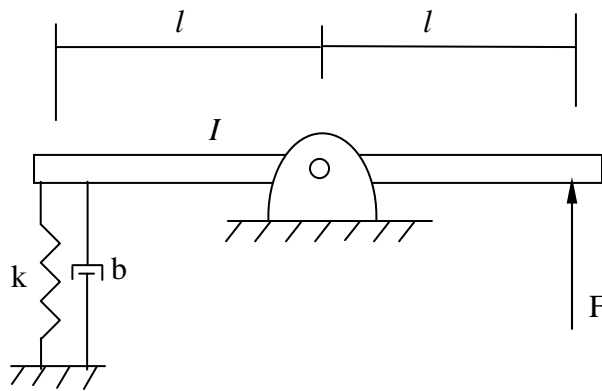

- What is $v(t)$ as a function of $e(t)$
- TF for the hydraulic actuator
- TF for the mechanical system (assuming small angles)
- Block diagram schematic of the system
- Sketch the Bode Diagram for each TF
- Determine the combined TF (from e to ω) and sketch its bode diagram
- Calculate the gain and phase at ω_0 for part f

2 Given a cart with mass m , size a spring and damper such that the system oscillates at 1 Hz and if started from rest at $x_0=10$ inches the maximum overshoot would be 1 inch

3. Given a cart with mass m , design a controller such that the closed-loop system oscillates at 1 Hz and if started from rest at $x_0=10$ inches the maximum overshoot would be 1 inch. A force is applied to the system through a hydraulic actuator.

4. Given the following block diagram, derive the transfer function from disturbance input (d) to output v.

a) TF?

b) Determine K such that the maximum error is 1 % of the disturbance input.

c) What is the close loop TF

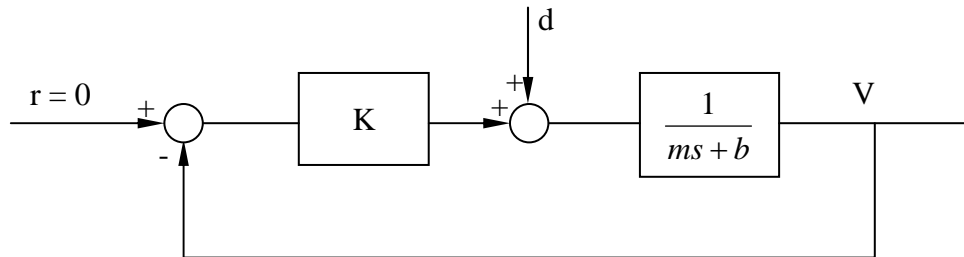

5. Develop the transfer function for the “High-Pass” Filter

a) TF from input voltage to output voltage (across the resistor)

b) Sketch the Bode Diagram (why is it called a “High Pass”)

c) What is the DC gain

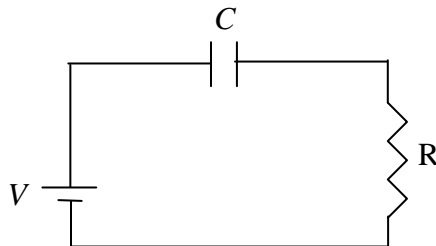

Matlab Assignment (Due 11/28/11).

1. Develop a controller for the *inverted* pendulum in HW #6 of length 1 meter and moment of inertia about its pivot of 1.25 kgm^2 (with no damping) controlled by a motor that provides a torque input to the system. Design the controller so that the controlled (closed-loop) system has a damping ratio of 0.707 and a bandwidth of 5 Hz.
 - a. What are the controller Gains?
 - b. Where are the closed-loop eigenvalues of the system?
 - c. Sketch the open loop roots of your system (poles and zeros)
 - d. Sketch the closed loop roots of your system (poles and zeros)
 - e. Simulate your controlled pendulum starting from rest at 20 degrees.

BONUS:

- f. Hit your pendulum with an impulse (after it is inverted) to test your controller. Provide a plot of the pendulum position and motor torque.
 - g. Add a unit force disturbance at the top of the pendulum. Calculate the steady state error. Plot the angle of the pendulum (starting from 20 degrees) and the control input with the disturbance force added. Does the steady state error match the predicted value?
 - h. Add integral control to remove the disturbance. Plot the angle of the pendulum (starting from 20 degrees) and the control input with the disturbance. Does the steady state error go to zero? Plot the control input – what is the steady state value of the control input?

2. Develop the linear model for a car traveling at 30 m/s (~65 mph) on FLAT terrain (assume a force input). The car has mass of 1500 kg and Coefficient of Drag of $25 \text{ Ns}^2/\text{m}^2$
 - a. Where is the eigenvalue of your system?
 - b. Design the *simplest* controller such that the Bandwidth of the closed-loop system is 1 Hz. Calculate the expected steady state error and controller force.
 - c. Now design a “Pre-reference” gain such that you have perfect tracking.
 - d. What is the steady state error of the controller when the car travels up a 10 degree hill? What is the controller force?
 - e. Simulate your controller (use the non-linear vehicle model). Provide a plot of vehicle speed and controller force (on one page) for *part b*, *part c* and *part d*
 - f. Design a controller so there is zero steady state error (without knowing the incline angle), a 1 Hz Bandwidth and less than 5% overshoot. What kind of controller did you use? Do you need the “Pre-Reference” gain? What is the controller force if the car is traveling up a 10 degree hill.
 - g. Provide a plot of vehicle speed and controller force (on one page) for traveling up the 10 degree incline for *part d* and *part e*