

Other Spring (Suspension System) Considerations, Continued

For statically indeterminate suspension systems (2 or more beams that deform by both bending and in tension/compression) use this approximation for the system spring constant:

$$k \approx \frac{N_{Leg}}{N_{Zig}} \frac{Ewt^3}{L^3}$$

Where N_{Leg} = # legs or spring elements

and N_{Zig} = # cutbacks (straight beam = 1, folded beam = 2, etc.)

Note: this CANNOT be used with the simple cantilever:

For the simple cantilever: $k = \frac{Ewt^3}{4L^3} \rightarrow$ the multi-beam suspension system is stiffer.

Example multi-beam suspension systems:

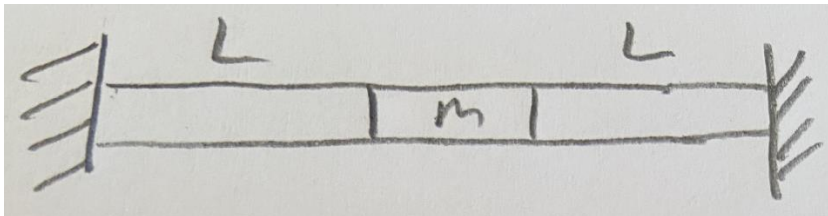

2 beams: $N_{Leg} = 2$, $N_{Zig} = 1$

Therefore $k \approx \frac{2Ewt^3}{L^3}$

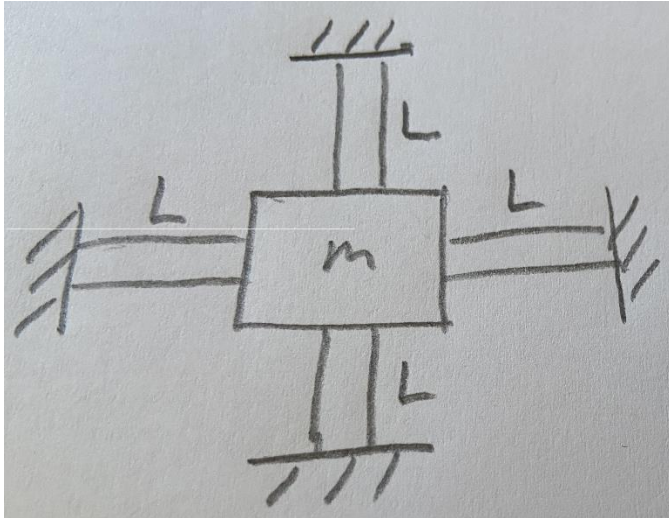

4 beams: $N_{\text{Leg}} = 4$, $N_{\text{Zig}} = 1$

Therefore $k \approx \frac{4Ewt^3}{L^3}$

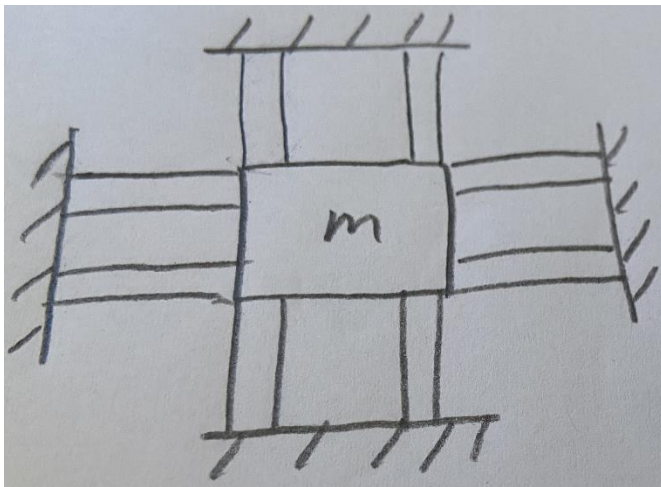

8 beams: $N_{\text{Leg}} = 8$, $N_{\text{Zig}} = 1$

Therefore $k \approx \frac{8Ewt^3}{L^3}$

Other Common MEMS Suspension Systems

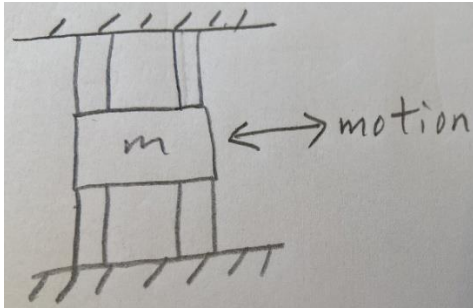

Called the Hammock Flexure

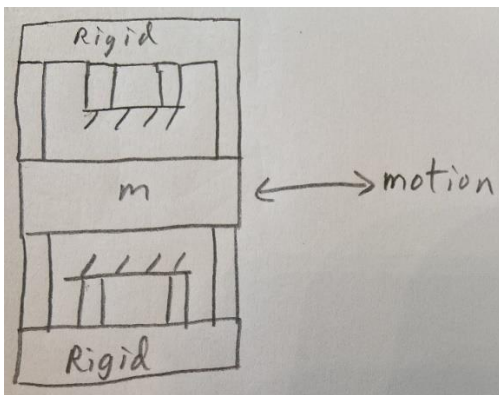

Called the Folded Flexure (has two additional rigid sections)

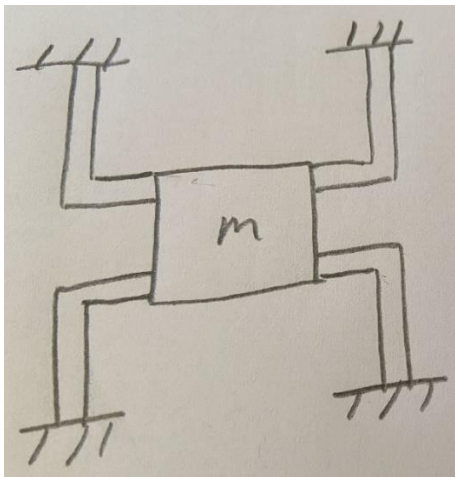

Called the Crab Leg Flexure

4 spring elements with two foldbacks

$$N_{\text{Leg}} = 4 \text{ and } N_{\text{Zig}} = 2$$

$$\text{Therefore } k \approx \frac{4Ewt^3}{2L^3} = \frac{2Ewt^3}{L^3}$$

Note: this design could move in-plane, out-of-plane, or torsionally. Each of these “modes” would have a different spring constant and therefore a different natural frequency.

Optimizing MEMS Suspension System Layout and Fabrication

Consider this MEMS suspension system design:

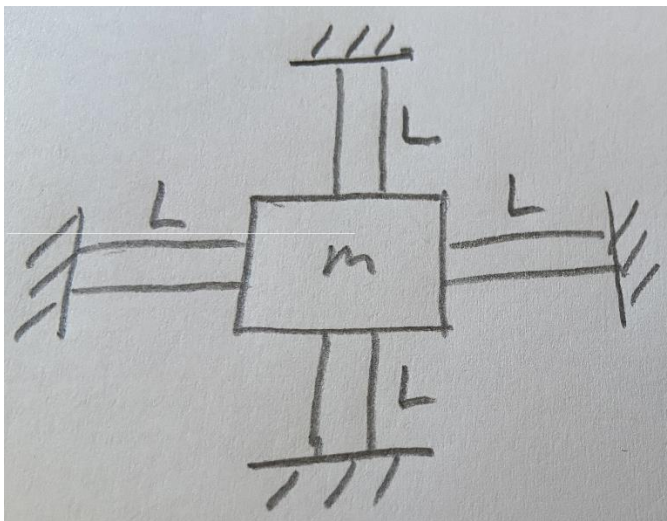

There is a lot of space (or rather, volume of Si) that is wasted between the spring elements. As shown, it was removed by etching, which is an expensive process. It is desirable to minimize that amount of bulk Si that must be etched. Etching is expensive. So, consider this design:

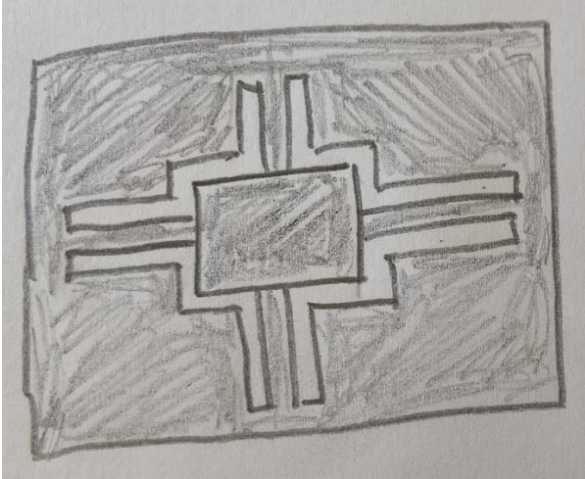

Here, only a small amount of Si around the spring elements and the proof mass have been etched, which reduces fabrication costs. However, there is a lot of unused chip “real estate.” We want to minimize unused chip real estate to minimize chip size and to therefore maximize the number of chips we can manufacture on a Si wafer, which minimizes chip cost. So consider this design:

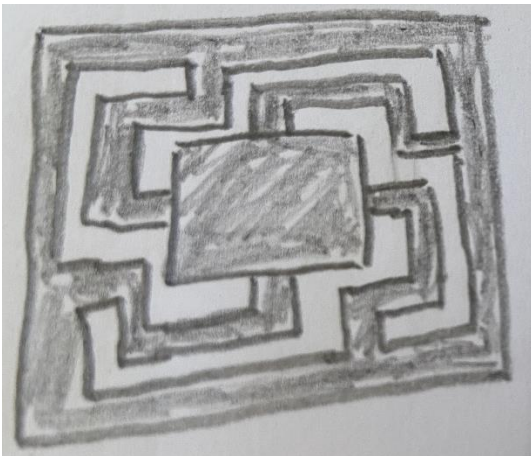

By wrapping the spring elements around the proof mass, we have minimized unused chip real estate and therefore chip size. However, there is always the Law of Unintended Consequences: the proof mass now rotates when it moves in and out of plane. Depending on the application, that might be a problem.

The Law of Unintended Consequences → job security for the engineer...

Vibration modes

Consider the MEMS cantilever spring with attached proof mass:

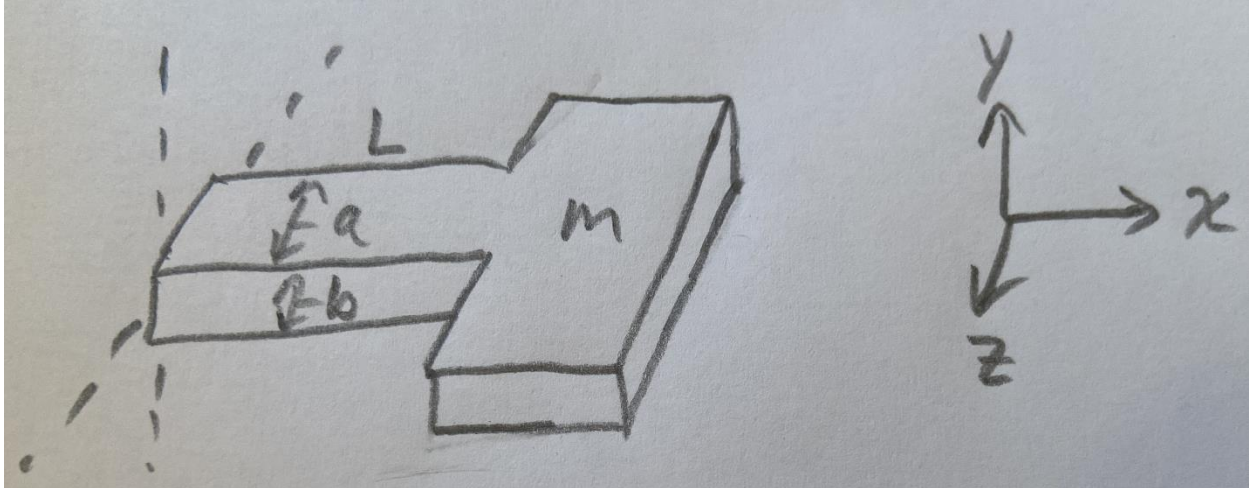

In the y -direction: $L, w = a, t = b \rightarrow k_y = \frac{Eab^3}{4L^3}$, and $\omega_{ny} = \sqrt{\frac{k_y}{m}}$

In the z -direction: $L, w = b, t = a \rightarrow k_z = \frac{Eba^3}{4L^3}$, and $\omega_{nz} = \sqrt{\frac{k_z}{m}}$

If $a = b \rightarrow \omega_{ny} = \omega_{nz}$

If $a = 2b \rightarrow k_y = \frac{E2b^4}{4L^3}$ and $k_z = \frac{E8b^4}{4L^3} \rightarrow \omega_{nz} = 2\omega_{ny}$

Therefore, it is stiffer in z than in y : motion in the z -direction (i.e. ω_{nz}) is a higher mode.

Higher modes of structures can be useful or problematic, depending on the application. Hand calculating higher modes is time consuming.

Finite Element Analysis (FEA) CAD tools can be used to model the structure and estimate the various vibration modes.

FEA CAD tool example:

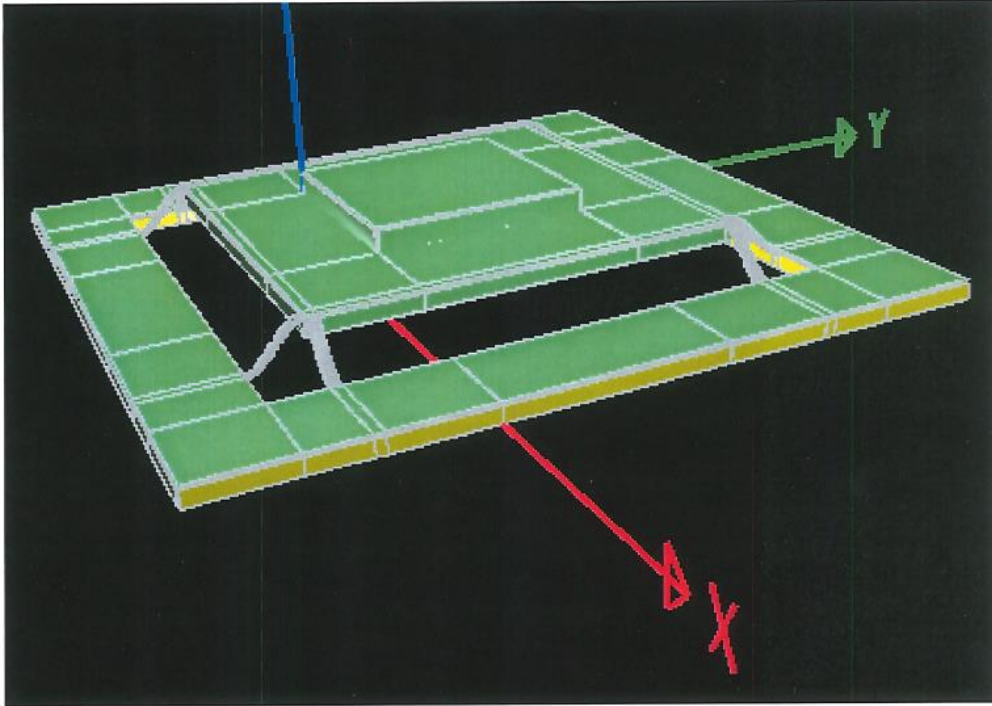

Mode 1: $f_0 = 901.992\text{Hz}$

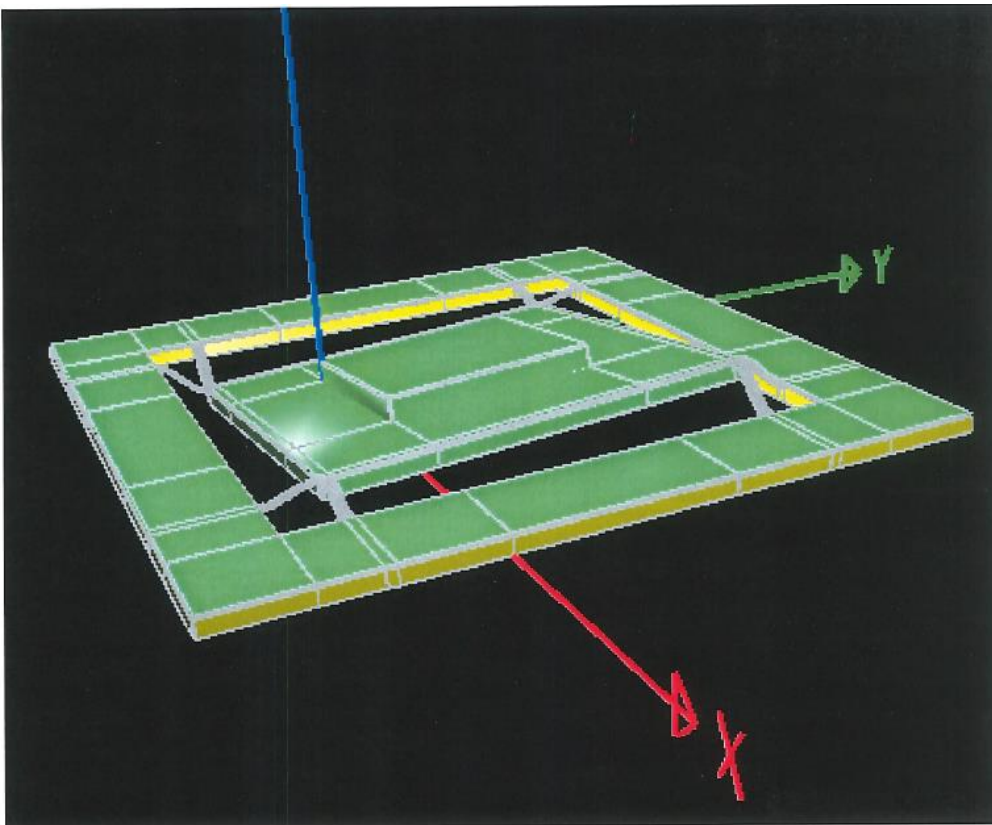

Mode 2: $f_0 = 1832.66\text{Hz}$

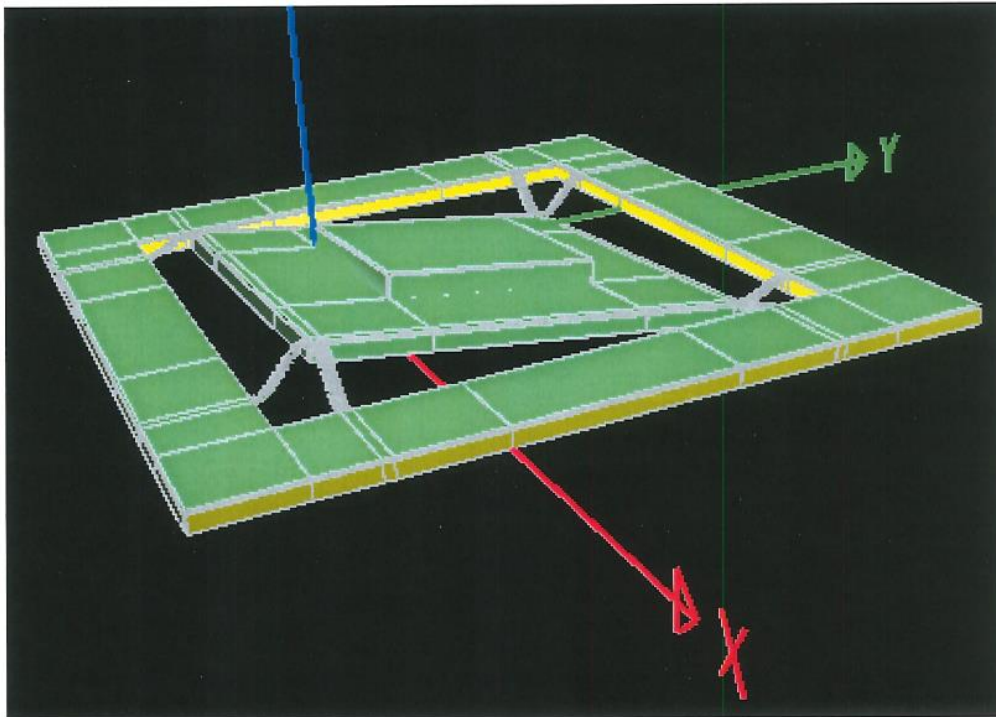

Mode 3: $f_0 = 1832.66\text{Hz}$

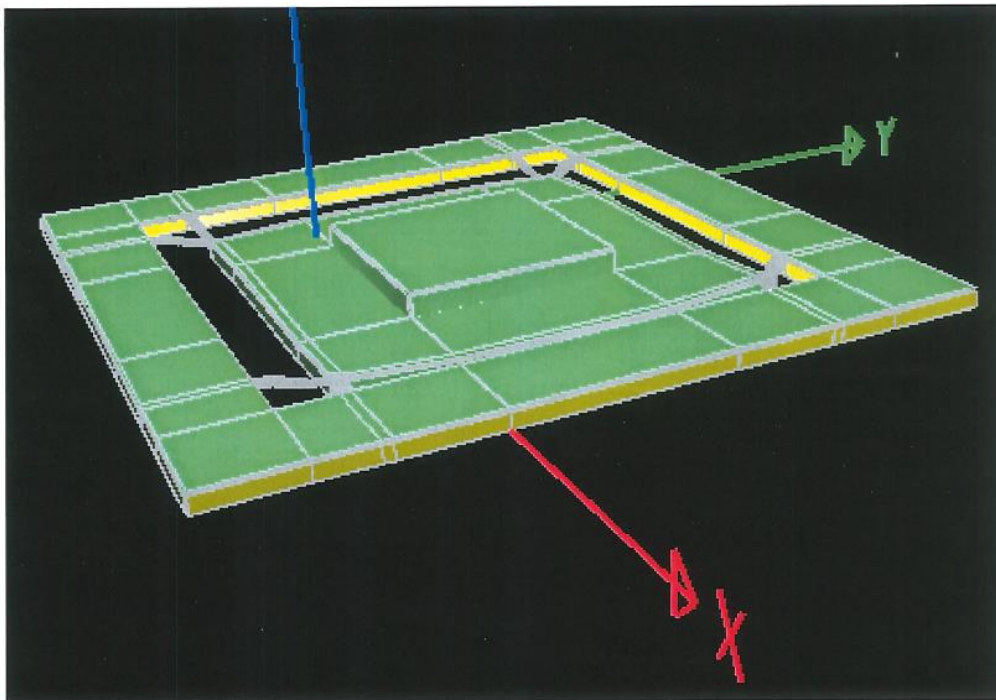

Mode 4: $f_0 = 25528.7\text{Hz}$

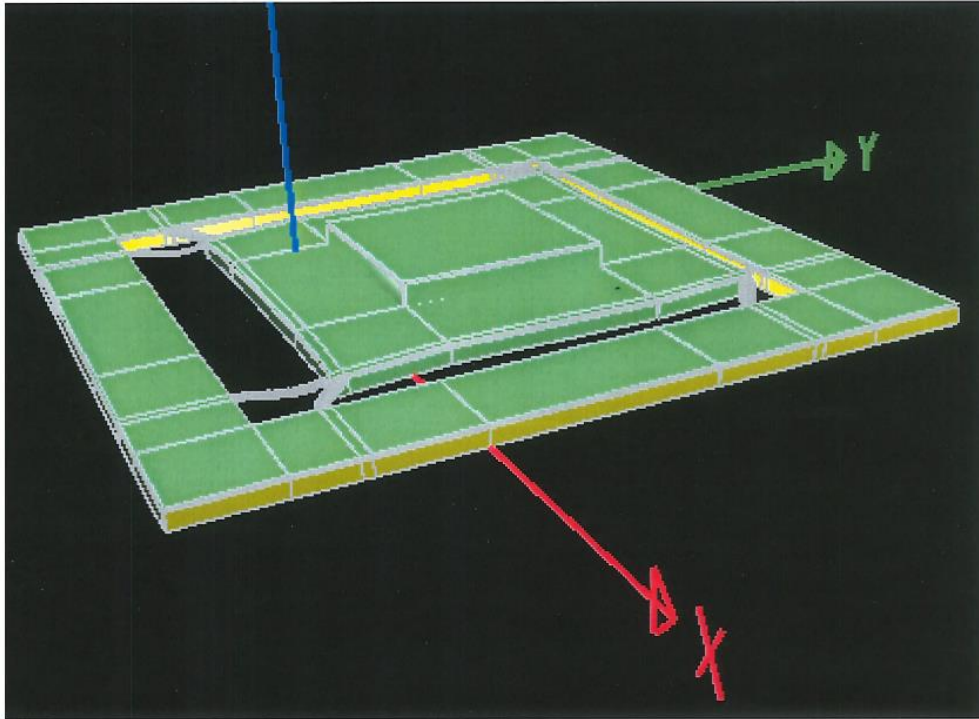

Mode 5: $f_0 = 25528.7\text{Hz}$

The natural frequency stays the same or goes up with each higher vibration mode.

Since, in reality, no elements are actually rigid, FEA CAD tools will find vibration modes that the simple spring-mass model does not predict.

Since spring-mass systems operate in the “real world”, where there is often little or no environmental mechanical energy above the audio frequency range ($\sim 20\text{ kHz}$) in *most* applications, vibration modes above about 20 kHz, can *usually* be ignored.

More MEMS suspension system notes

1. Consider the crab leg suspension system below:

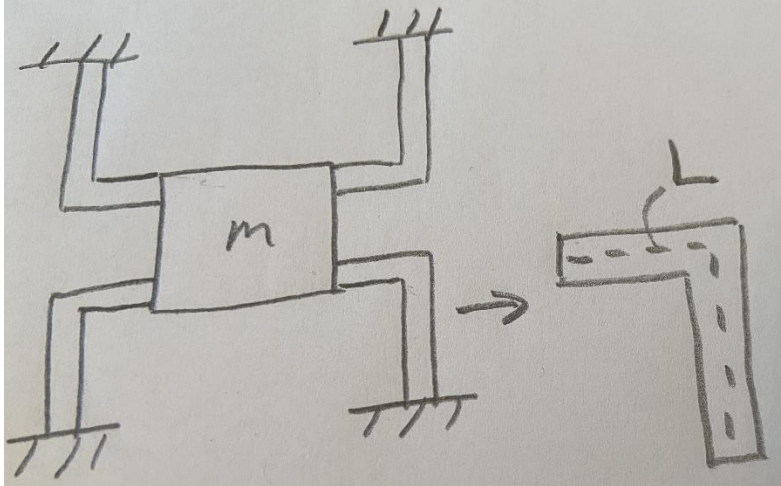

L for each spring member is the length along its center line.

2. Typically, a lumped model approach is used to model the system:

- Proof mass \rightarrow completely rigid, with a uniform density
- Springs \rightarrow no mass

However, if the springs are large compared to the proof mass, their mass cannot be ignored. To account for the springs' mass when the springs are large, 1/3 of the springs' mass may be used with the proof mass:

$$m_t = m_{pm} + m_s/3$$

This yields a better approximation for total mass than just the mass of the proof mass alone.

Note: for class assignments, ignore the mass of the springs unless explicitly told to include it.