

Tuesday, 1/31/23

### Constraints on $A(j\omega)$

The simplest electronic oscillators are op amp based, and  $A(j\omega)$  is typically a simple op amp fixed gain amplifier. Electromechanical oscillators often employ op amps in the electronic feedback networks. Consider the negative gain and positive gain op amp amplifier circuits shown below.

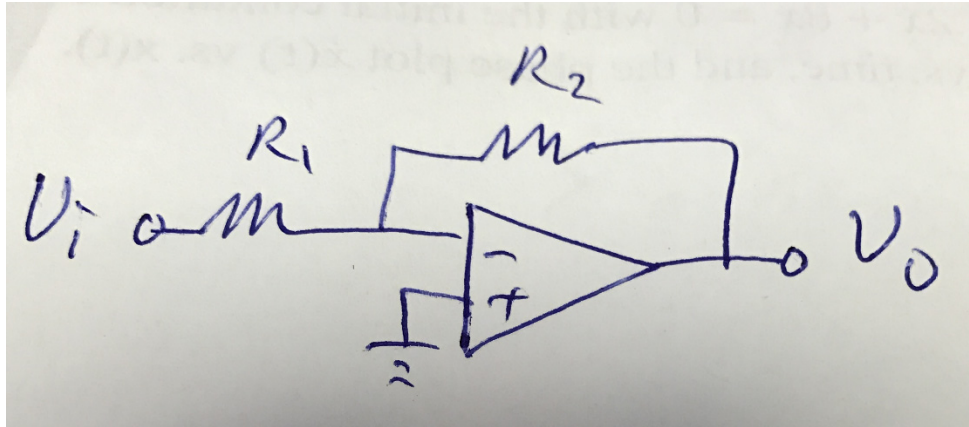

Negative Gain Configuration

$$V_o = -V_i \frac{R_2}{R_1}$$

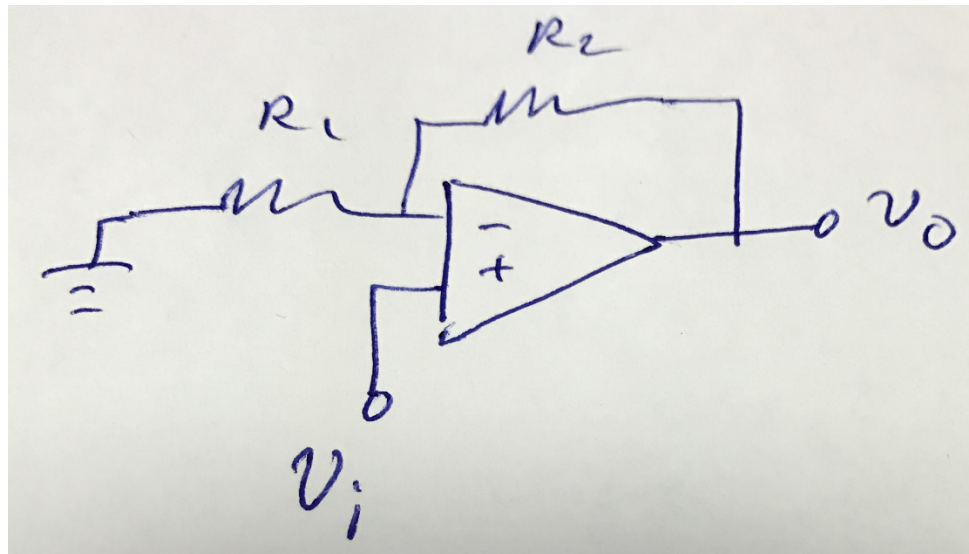

Positive Gain Configuration

$$V_o = V_i \left( 1 + \frac{R_2}{R_1} \right)$$

The gain equations above are for ideal op amp performance. However, op amps are non-ideal, and these non-idealities limit their performance in oscillator and other applications:

(1) Op amp frequency response

The op amp is a complex circuit comprised of nonlinear active elements (primarily transistors), as well as passive elements (primarily capacitors). Op amps possess many poles. However, quality op amps are compensated and can be modelled by:

$$A(j\omega) = \frac{A_{OL}}{1 + j\frac{\omega}{\omega_a}},$$

where  $A_{OL}$  is the maximum open loop gain of the op amp, and  $\omega_a$  is due to the dominant pole of the compensated op amp and is the 3 dB frequency. At  $\omega_a$ , the op amp open loop gain has dropped by 3 dB and has a  $-45^\circ$  phase shift. At  $\omega_a$  and higher, the open loop gain decrease by approximately 20 dB per decade. The unity gain bandwidth,  $\omega_t = A_{OL} \times \omega_a$ . Consider an op amp modelled with  $A_{OL} = 1 \times 10^8$  V/V and  $\omega_a = 2\pi(10 \times 10^6)$  rad/s:

Shown on Next Page

As such, the gain bandwidth (GBW) product is necessary in selecting an appropriate op amp for a given oscillator circuit. Although varying somewhat with the actual amplifier configuration, the 3 dB bandwidth (and the  $-45^\circ$  phase shift) for a particular amplifier design is approximately proportional to the open loop 3 dB bandwidth divided by the closed loop gain. The higher the required gain to achieve oscillation for a particular oscillator circuit, the lower the achievable oscillation frequency with that circuit. Since op amps will have at least a  $45^\circ$  phase shift at the BW limit for a particular gain, and probably a greater phase shift due to higher frequency poles, the useful frequency range for a particular gain is usually no more than 1/10 of the BW at that gain.

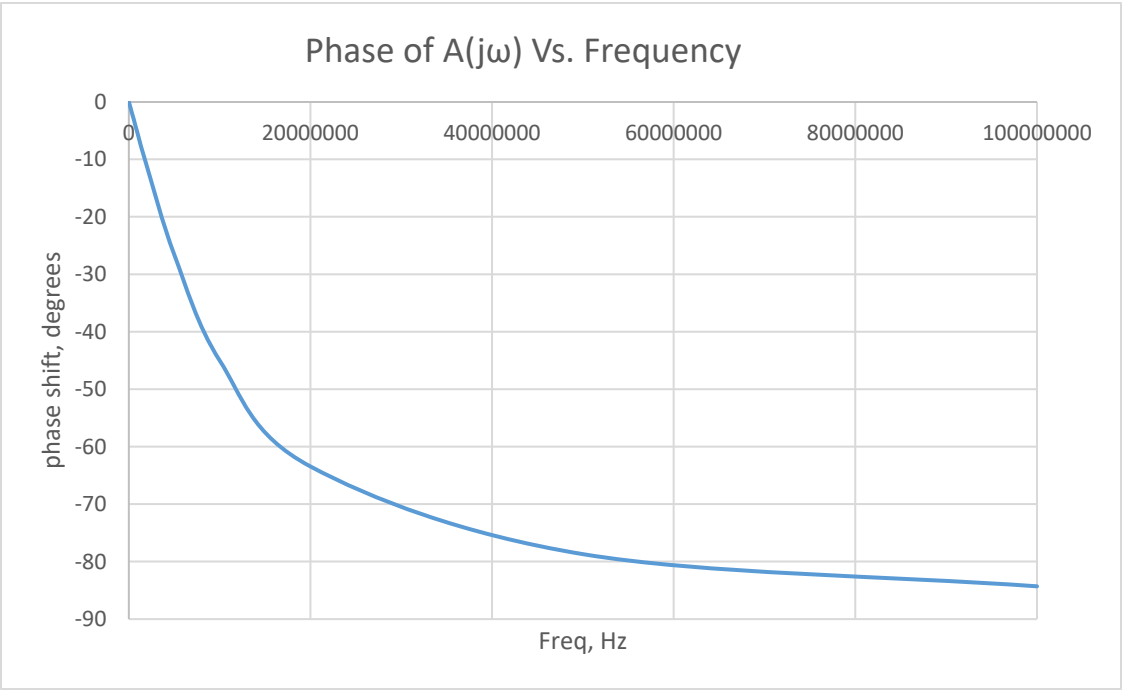
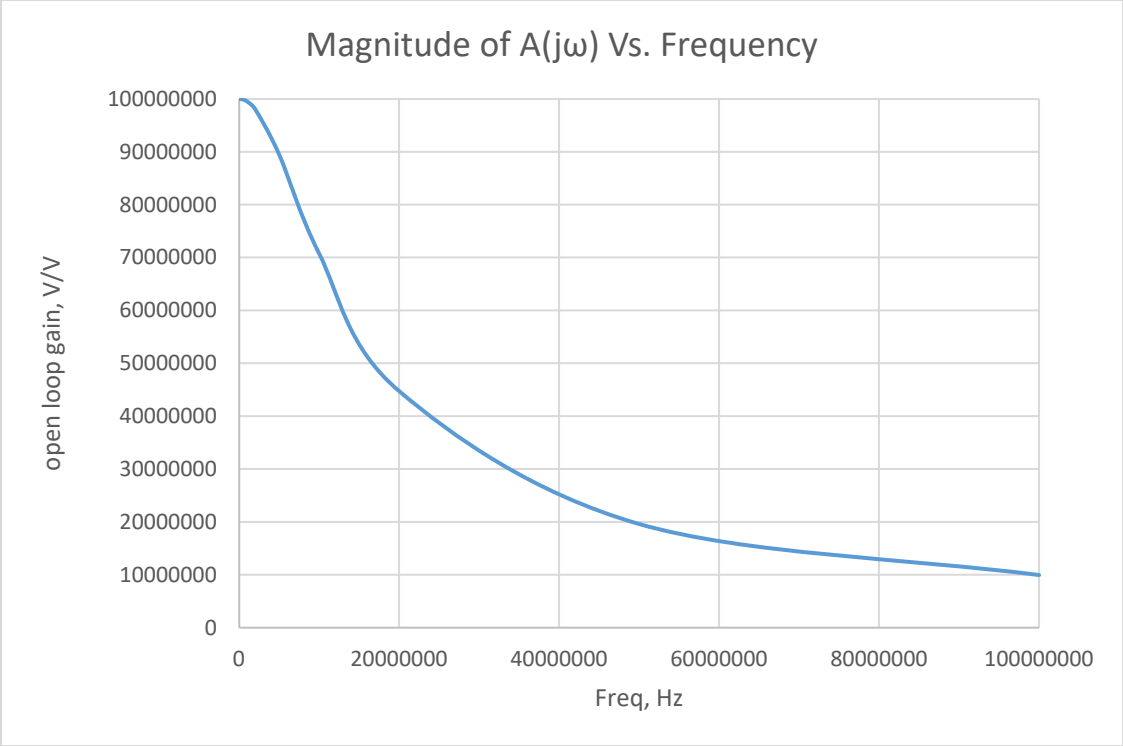

## (2) Slew rate limit

Most op amps have optimal performance with small signals. Large amplitude signals can be affected by the slew rate limitation of the op amp at lower frequencies than small amplitude signals. Consider a sinusoid of the form:

$$V(t) = V_p \sin(\omega t).$$

The maximum value of the derivative of  $V(t)$  will give us the minimum slew rate needed for the op amp. Therefore

$$\dot{V}(t) = \omega V_p \cos(\omega t)$$

Which is maximum at  $\omega t = 0$ .

Therefore, the op amp slew rate should be greater than  $2\pi V_p f$ , where  $f$  is the oscillation frequency.

## (3) Circuit considerations

Good circuit design techniques should be employed in all op amp circuits, including the use of decoupling capacitors, balancing the impedances between the two inputs, and restricting the size of feedback resistors to reasonable values. If resistances are too small, currents may be too large for the op amp to sufficiently source or sink. If resistances are too large, noise issues can result and/or the frequency response of the op amp circuit can be adversely affected. Use good grounding techniques: ground planes or star configurations for power and ground signals.

## (4) Op amp phase response

The phase response of an op amp will certainly affect the oscillator circuit design. A nonlinear phase response is particularly problematic for chaotic oscillator circuits, which operate over a wide bandwidth compared to sinusoidal oscillator circuits.

These constraints limit the use of op amp based oscillators to low frequency operation, often below 1 MHz, although operation up to a few MHz may be

possible with high frequency op amps in low gain oscillator circuits. As a result, op amp based oscillator circuits requiring the lowest possible gain are desirable for the highest frequency operation. Also, in oscillator circuits that employ multiple op amps, it may be possible to distribute the required gain among several op amp stages, thereby reducing the gain that any one op amp subcircuit has to provide.

### Constraints on $\beta(j\omega)$

The  $\beta(j\omega)$  subcircuit often consists of some passive elements (R, C and L) and occasionally op amps. The primary purpose of the  $\beta(j\omega)$  subcircuit is to provide a closed loop phase delay at a desired frequency to satisfy the Barkhausen stability criterion for oscillation. Therefore, both the magnitude response and the phase response for  $\beta(j\omega)$  subcircuits are important. Let's consider some simple circuits that are sometimes used in  $\beta(j\omega)$  subcircuits:

#### (1) Passive one-pole RC lowpass filter

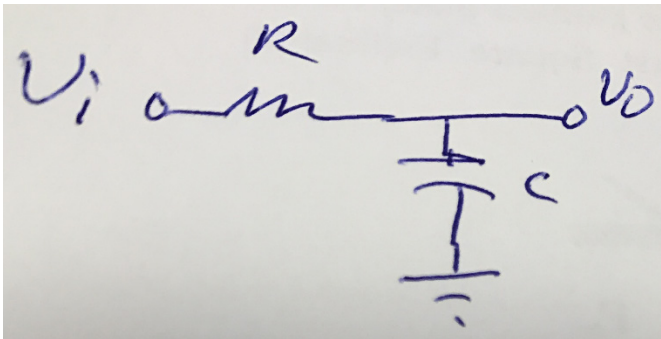

$$G(j\omega) = \frac{V_o}{V_i}(j\omega) = \frac{1}{1 + j\omega RC}$$

$$|G(j\omega)| = \frac{1}{\sqrt{1 + (\omega RC)^2}}$$

$$\angle G(j\omega) = -\tan^{-1}(\omega RC)$$

$$\text{Filter resonant frequency} = \omega_r = \frac{1}{RC}$$

At  $\omega = \omega_r$ :

$$|G(j\omega_r)| = \frac{1}{\sqrt{2}}$$

And

$$\underline{|G(j\omega_r)|} = -45^\circ$$

(2) Passive one-pole RC highpass filter

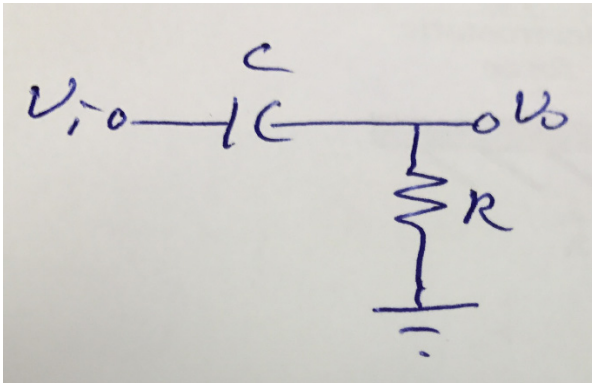

$$G(j\omega) = \frac{V_o}{V_i}(j\omega) = \frac{j\omega}{j\omega + \frac{1}{RC}}$$

$$|G(j\omega)| = \frac{\omega}{\sqrt{\left(\frac{1}{RC}\right)^2 + (\omega)^2}}$$

$$\underline{|G(j\omega)|} = 90^\circ - \tan^{-1}(\omega RC)$$

$$\text{Filter resonant frequency} = \omega_r = \frac{1}{RC}$$

At  $\omega = \omega_r$ :

$$|G(j\omega_r)| = \frac{1}{\sqrt{2}}$$

And

$$\underline{|G(j\omega_r)|} = 45^\circ$$

### (3) Simple RC BPF

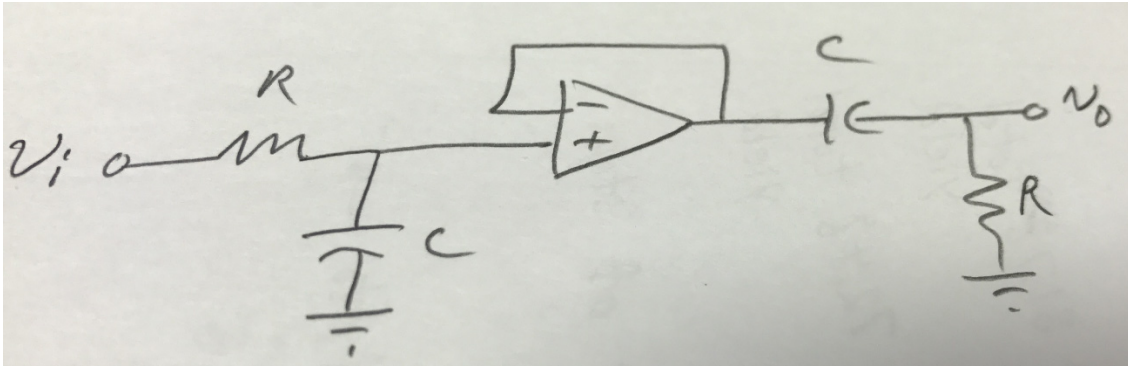

$$G(j\omega) = \frac{V_o}{V_i}(j\omega) = \frac{j\omega CR}{1 - (\omega CR)^2 + 2j\omega CR}$$

$$|G(j\omega)| = \frac{\omega CR}{\sqrt{(1 - (\omega CR)^2)^2 + (2\omega CR)^2}}$$

$$\underline{|G(j\omega)|} = 90^\circ - \tan^{-1}\left(\frac{2\omega CR}{1 - (\omega CR)^2}\right)$$

$$\text{Filter resonant frequency} = \omega_r = \frac{1}{RC}$$

At  $\omega = \omega_r$ :

$$|G(j\omega_r)| = \frac{1}{2}$$

And

$$\underline{|G(j\omega_r)|} = 0^\circ$$

## Simple Op Amp Oscillators

### 1) The Wein Bridge Oscillator

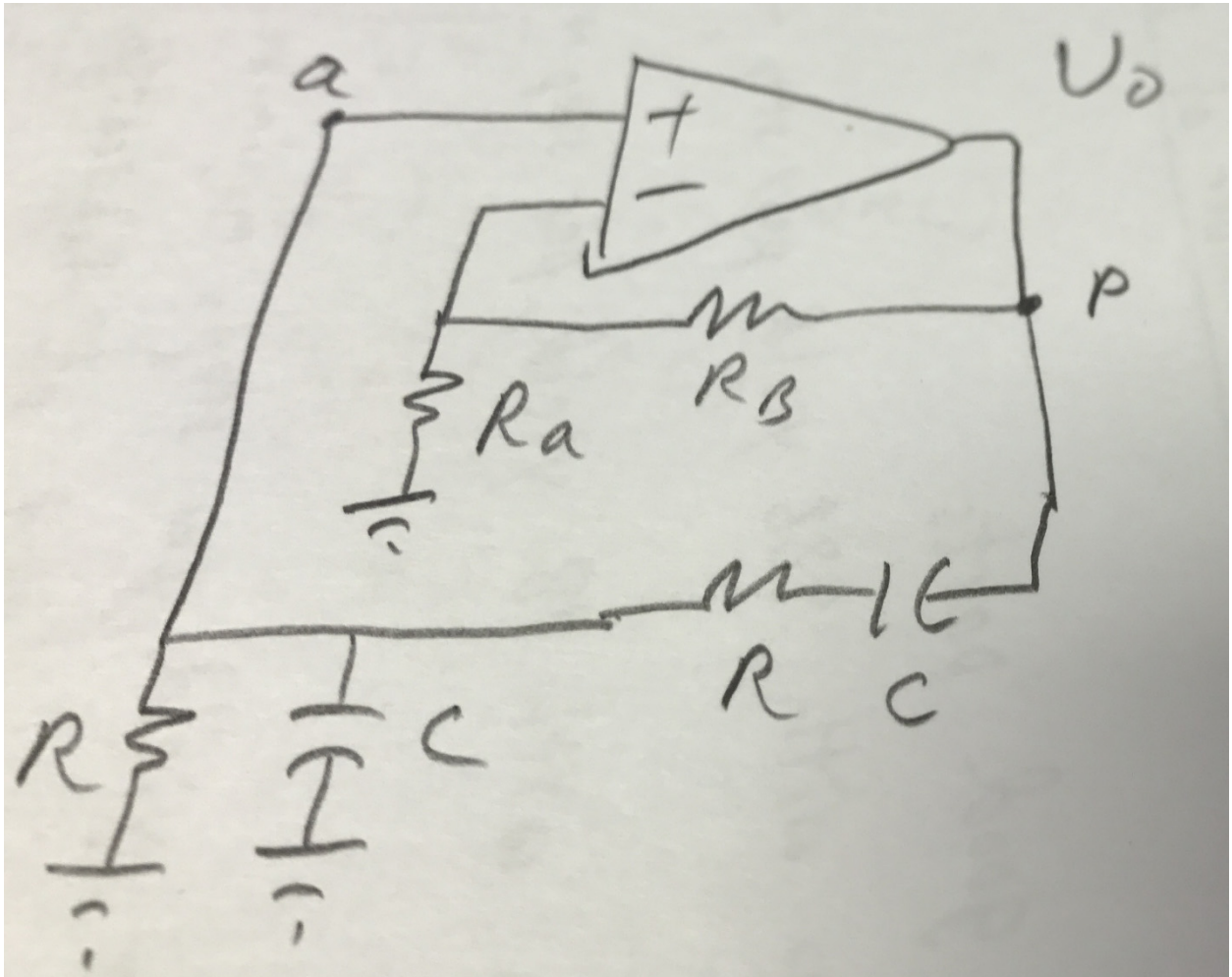

It consists of a positive gain op amp circuit,  $A(j\omega)$  and a RC filter,  $\beta(j\omega)$ .

$$\text{Therefore } A(j\omega) = \frac{V_P}{V_a} = 1 + \frac{R_B}{R_a}$$

$$\text{And } \beta(j\omega) = \frac{j\omega RC}{1 - (\omega RC)^2 + 3j\omega RC}$$

Breaking the circuit at point a (looking into the high impedance op amp input terminal):

$$A(j\omega)\beta(j\omega) = \frac{j\omega RC \left(1 + \frac{R_B}{R_a}\right)}{1 - (\omega RC)^2 + 3j\omega RC}$$

So:



$$|A(j\omega)\beta(j\omega)| = \frac{\omega RC \left(1 + \frac{R_B}{R_a}\right)}{\sqrt{(1 - (\omega RC)^2)^2 + (3\omega RC)^2}} = 1$$

to satisfy the Barkhausen stability criterion (BSC) for a positive feedback configuration.

$$\text{Let } \omega = \frac{1}{RC}$$

Therefore

$$|A(j\omega)\beta(j\omega)| = \frac{\left(1 + \frac{R_B}{R_a}\right)}{3} = 1$$

Now select  $R_B = 10 \text{ k}\Omega$  and  $R_a = 5 \text{ k}\Omega$

The phase response:

$$\underline{|A(j\omega)\beta(j\omega)|} = \tan^{-1}(\infty) - \tan^{-1}\left(\frac{3\omega RC}{1 - (\omega RC)^2}\right)$$

$$\text{At } \omega = \frac{1}{RC}:$$

$$\underline{|A(j\omega)\beta(j\omega)|} = \tan^{-1}(\infty) - \tan^{-1}\left(\frac{3\omega RC}{0}\right) = 0^\circ \text{ which also satisfies the BSC}$$

The circuit above “should” oscillate due to nonlinearities in the circuit above (op amp) not accounted for in the circuit model. But the oscillation amplitude is not controlled. An AGC circuit would be needed to control the amplitude.

# PSpice Simulated Wien Bridge Oscillator

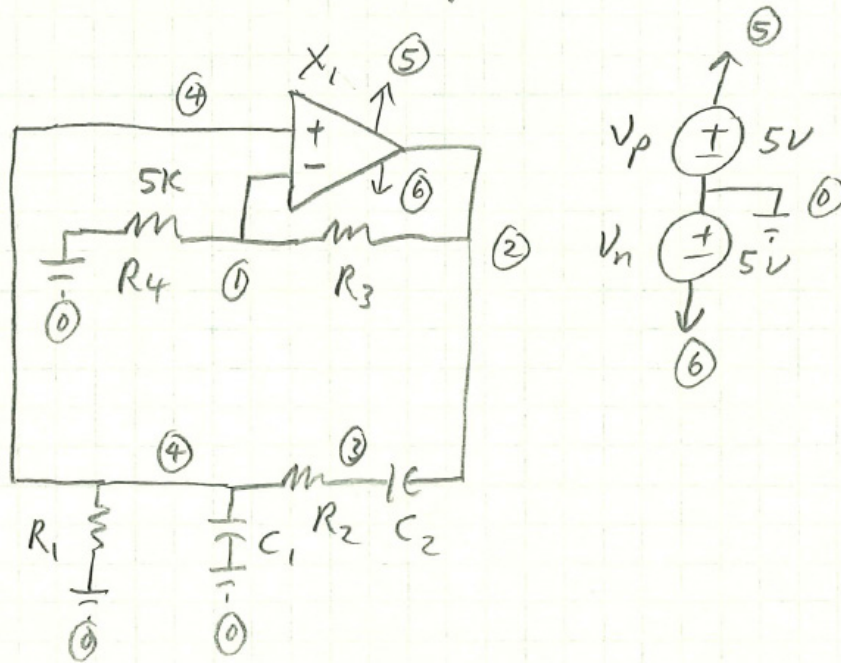

$$f = \frac{1}{2\pi RC} = \frac{1}{2\pi(159.155)(1 \times 10^{-6})} = 1000 \text{ Hz}$$

$$C_1 = C_2 = 1 \mu\text{F}$$

$$R_1 = R_2 = 159.155 \Omega$$

$$1 + \frac{R_3}{R_4} = 3 \rightarrow R_4 = 5 \text{ K}\Omega, R_3 = 10 \text{ K}\Omega$$

$X_1$ : AD8610 op amp  $\rightarrow$  25 MHz GBW product

Result  $\rightarrow$  no oscillation

$\therefore R_3$  increased to 15 K $\Omega$  to achieve oscillation

Output: Distorted sinusoid:  $f = 857.93 \text{ Hz}$

Possible causes for lower freq:

- ① phase shift in op amp
- ② nonlinear distortion near power supply rails

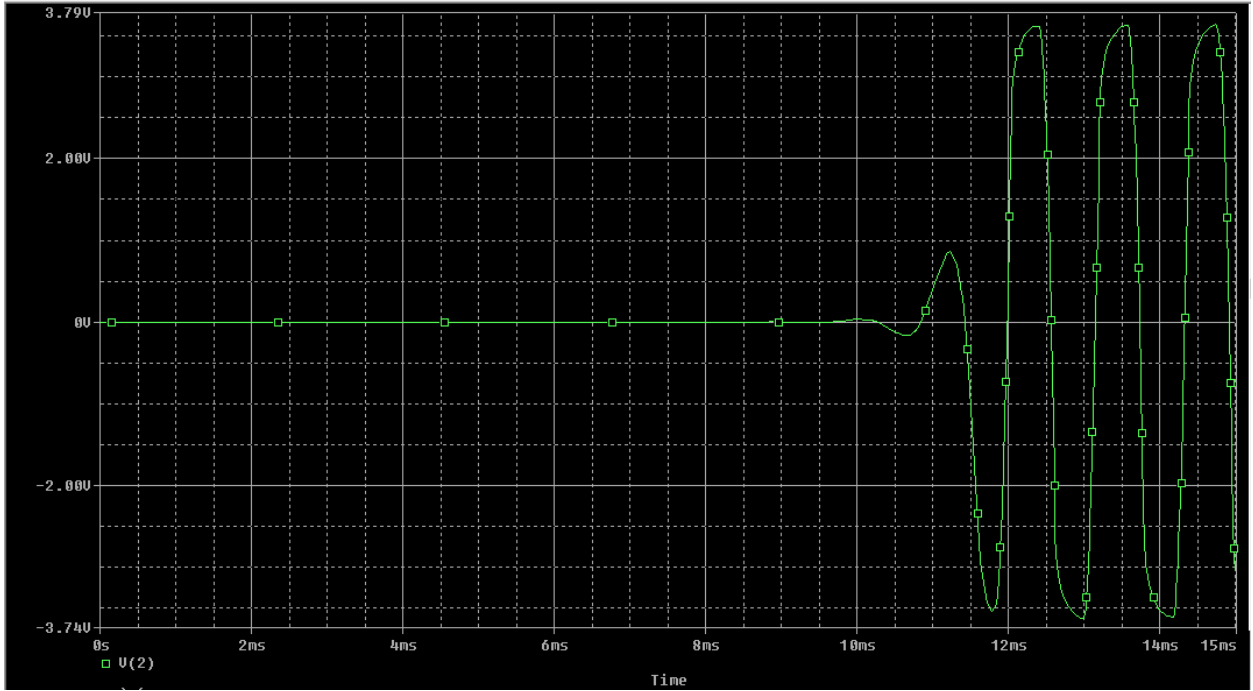

PSpice Simulation Output

# PSpice Simulated Wein Bridge Osc. with AGC

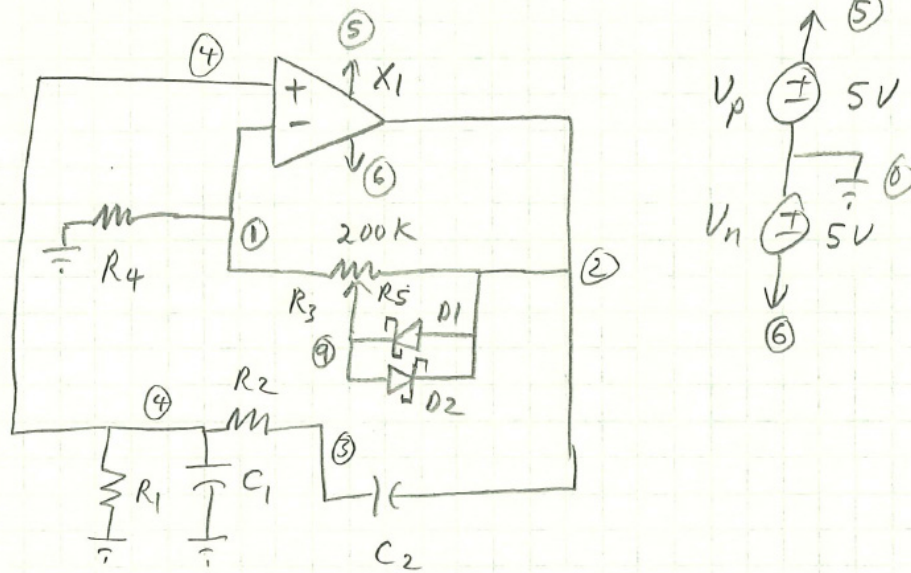

$D_1, D_2 \rightarrow$  Schottky Diode, 0.5V turn on voltage

$R_3 - R_5 \rightarrow$  200k pot

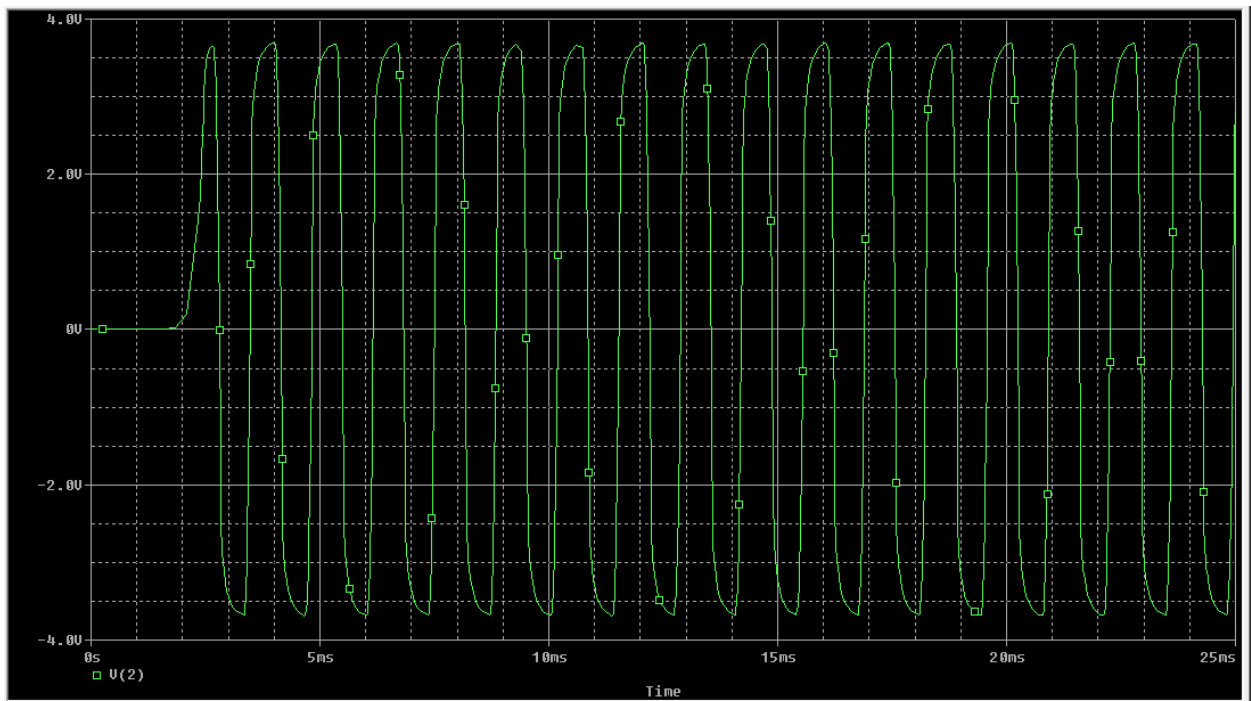

$R_3 = 180 \text{ k}\Omega, R_5 = 20 \text{ k}\Omega$

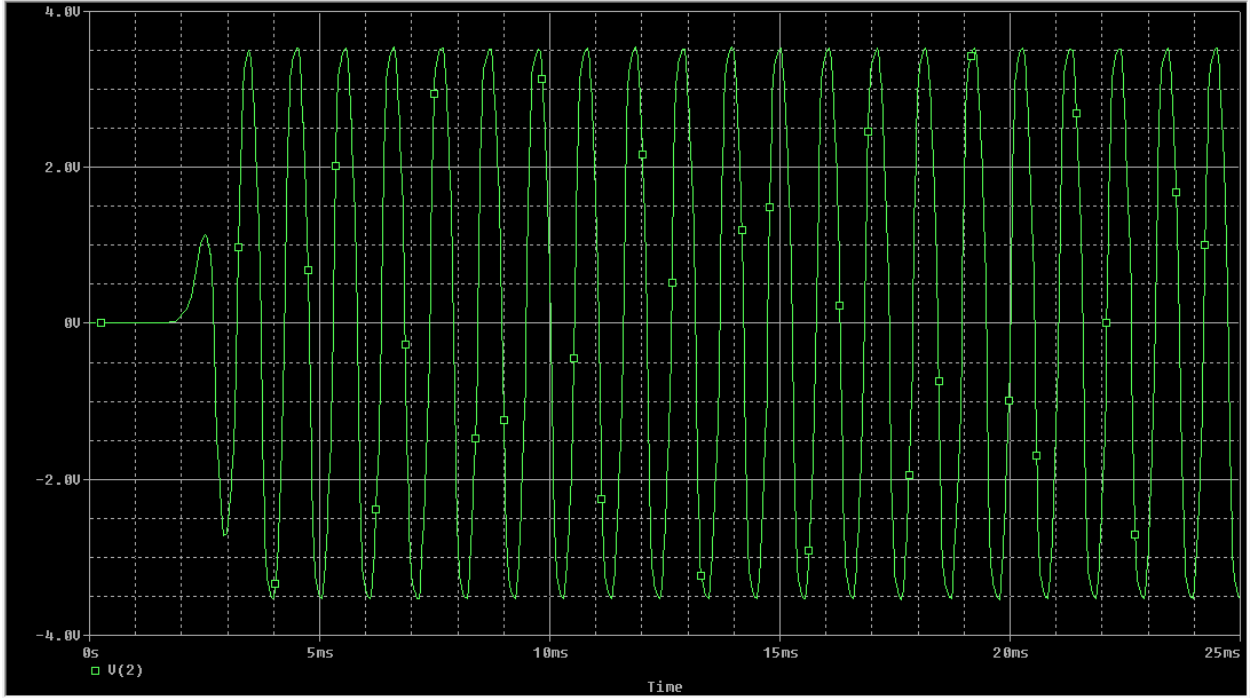

$R3=80\text{ k}\Omega$ ,  $R5=120\text{ k}\Omega$

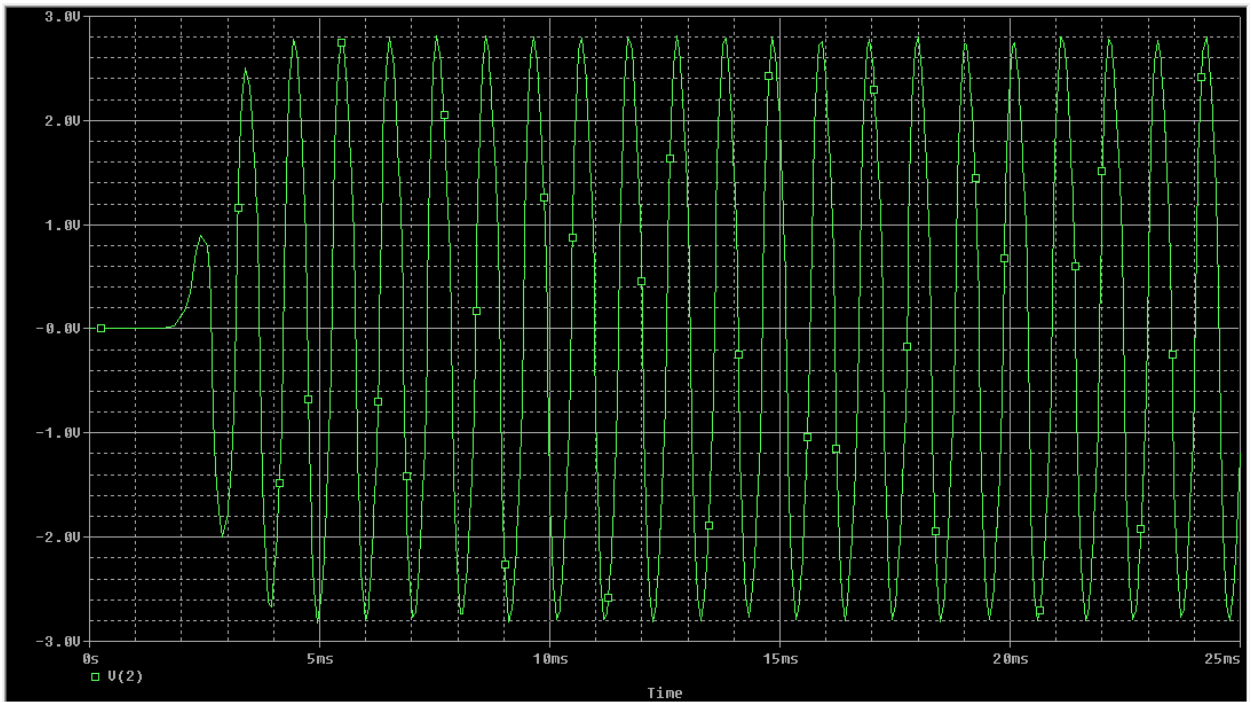

$R3=65\text{ k}\Omega$ ,  $R5=135\text{ k}\Omega$

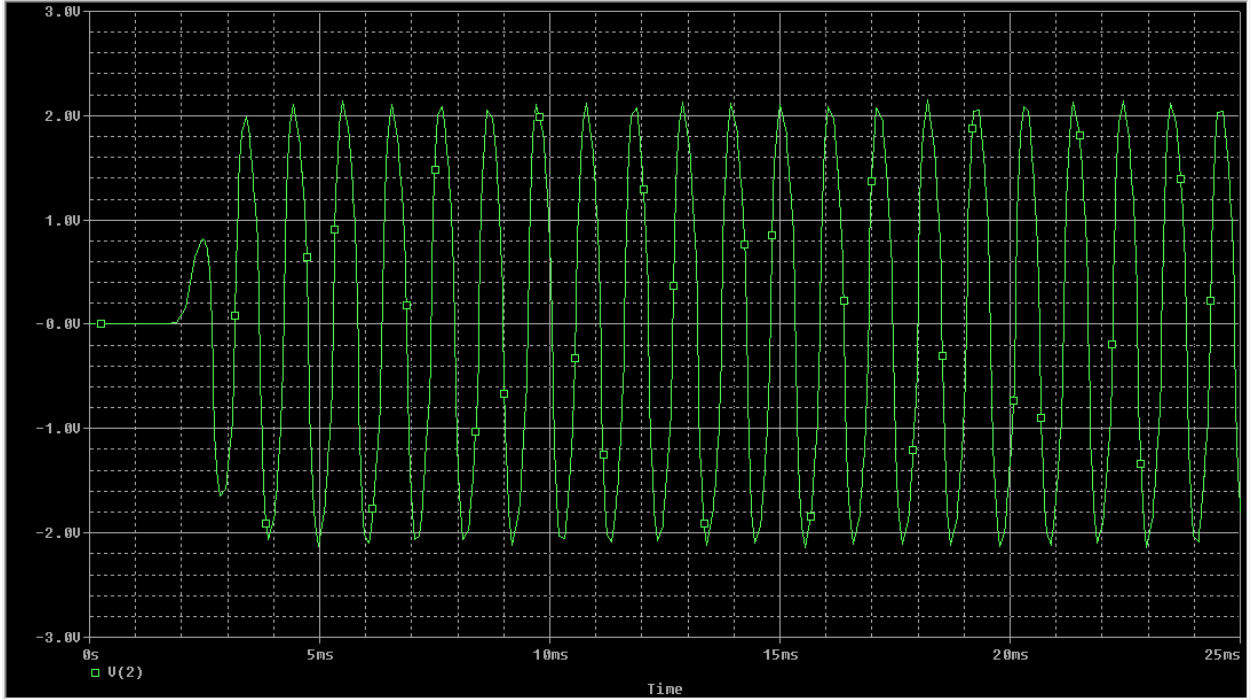

$R3=55\text{ k}\Omega$ ,  $R5=145\text{ k}\Omega$

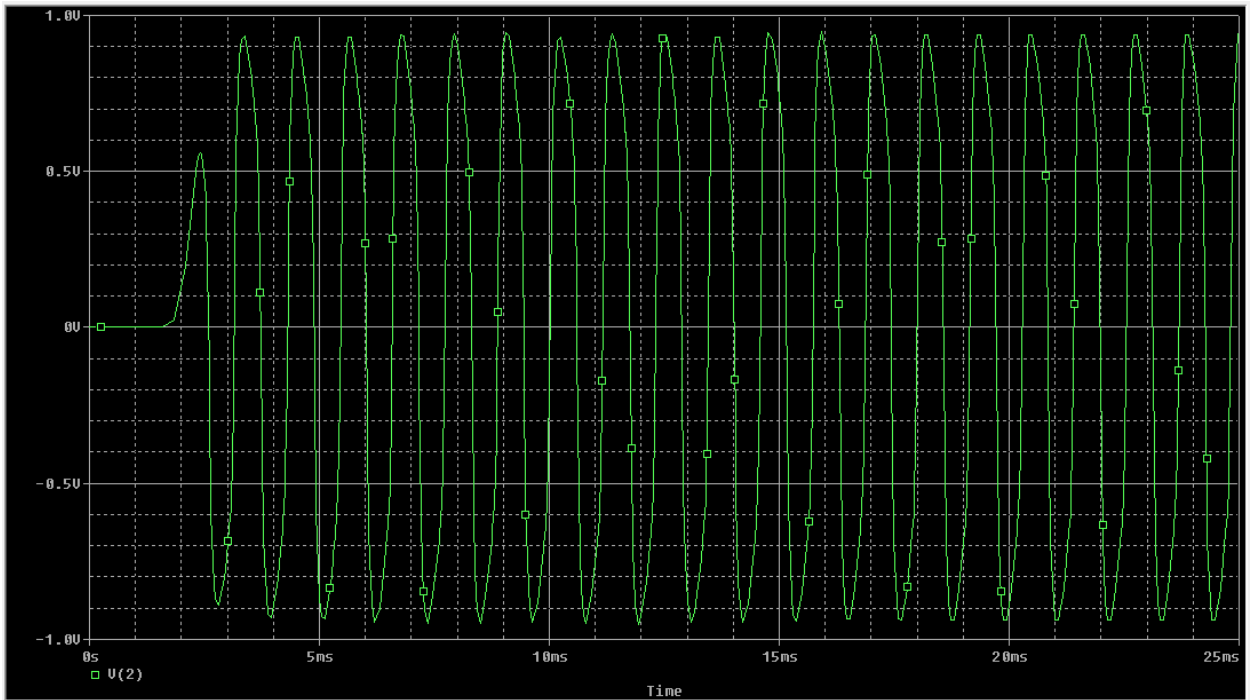

$R3=10\text{ k}\Omega$ ,  $R5=190\text{ k}\Omega$

The output is still somewhat distorted. It could be filtered to improve sinusoidal quality.

More complex AGC circuits are published using a rectifying diode on the output followed by a RC LPF, with the filter output attached to the gate of a jFET used as a voltage controlled resistor, tied to the numerator resistor of the amplifier circuit. However, I could not get a simple circuit like this to function correctly in PSpice due to the FET not operating as desired when the drain terminal voltage went negative.

### Phase Shift Oscillator

The phase shift oscillator consists of an  $A(j\omega)$  negative gain stage, and a  $\beta(j\omega)$  stage that provides a  $+180^\circ$  or a  $-180^\circ$  phase shift at the oscillation frequency.

a. Consider the RC ladder network below:

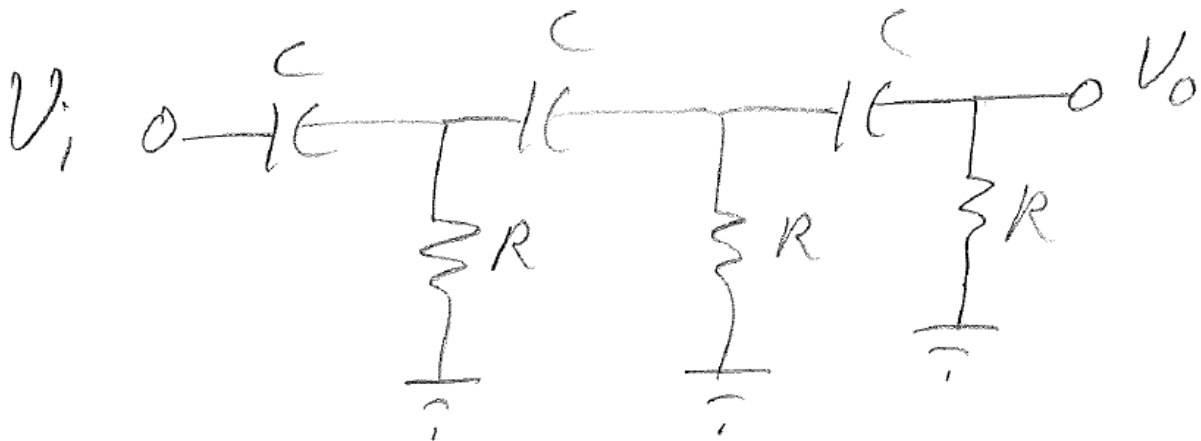

Procedure for analyzing any ladder network:

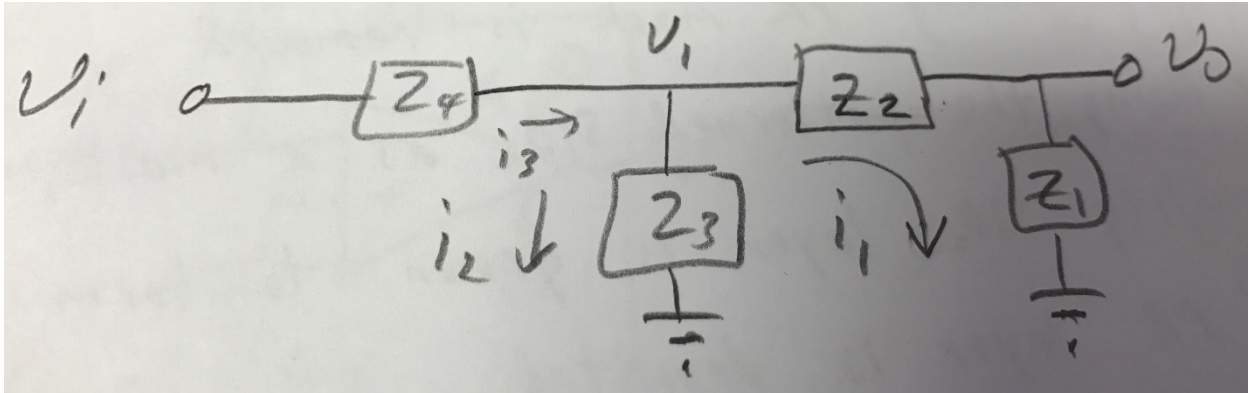

$$i_1 = \frac{v_o}{Z_1} \quad (1)$$

$$v_1 = v_o + i_1 Z_2 \quad (2)$$

$$i_2 = \frac{v_1}{Z_3} \quad (3)$$

$$i_3 = i_1 + i_2 \quad (4)$$

$$v_i = v_1 + i_3 Z_4 \quad (5)$$

Then (1)  $\rightarrow$  (2), (2)  $\rightarrow$  (3), (1) and (3)  $\rightarrow$  (4), (2) and (4)  $\rightarrow$  (5),

Then calculate  $\frac{v_o}{v_i}$  from result

### Passive Ladder Filters

- (1) Use the circuit topology shown above, with a nominal  $1 \Omega$  input resistor and a nominal  $1 \Omega$  output or load resistor, and a nominal LP cutoff frequency of  $1 \text{ rad/s}$ .
- (2) Select the type of filter you desire (LP, HP, BP, BR, etc.), the style (Butterworth, Bessel, Chebyshev, etc.), and the order of the filter.
- (3) Get the polynomial coefficients from a table, Matlab or a filter design program.
- (4) Scale the polynomial coefficients based on the filter type desired.
- (5) Scale the polynomial coefficients to achieve the desired cutoff frequency.
- (6) Scale the polynomial coefficients to achieve reasonable values for filter resistances, capacitances and inductors.
- (7) Build and test...



Back to the oscillator...

Through circuit analysis of the RC ladder network used here:

$$\frac{V_o}{V_i} = \frac{(RCs)^3}{(RCs)^3 + 6(RCs)^2 + 5(RCs) + 1}$$

$$\frac{V_o}{V_i}(j\omega) = \frac{-j(RC\omega)^3}{-j(RC\omega)^3 - 6(RC\omega)^2 + 5j(RC\omega) + 1}$$

Magnitude:

$$\left| \frac{V_o}{V_i}(j\omega) \right| = \frac{(RC\omega)^3}{\sqrt{(1 - 6(RC\omega)^2)^2 + (5RC\omega - (RC\omega)^3)^2}}$$

Phase:

$$\underline{\left| \frac{V_o}{V_i}(j\omega) \right|} = -\tan^{-1}(\infty) - \tan^{-1}\left(\frac{5RC\omega - (RC\omega)^3}{1 - 6(RC\omega)^2}\right)$$

$$\text{At } \omega = \frac{1}{RC\sqrt{6}}, \quad \underline{\left| \frac{V_o}{V_i}(j\omega) \right|} = -180^\circ$$

$$\text{And, at } \omega = \frac{1}{RC\sqrt{6}}, \quad \left| \frac{V_o}{V_i}(j\omega) \right| = \frac{1}{29}$$

Therefore,  $A(j\omega) = -29$  for oscillation.

Consider the resulting oscillator circuit shown below:

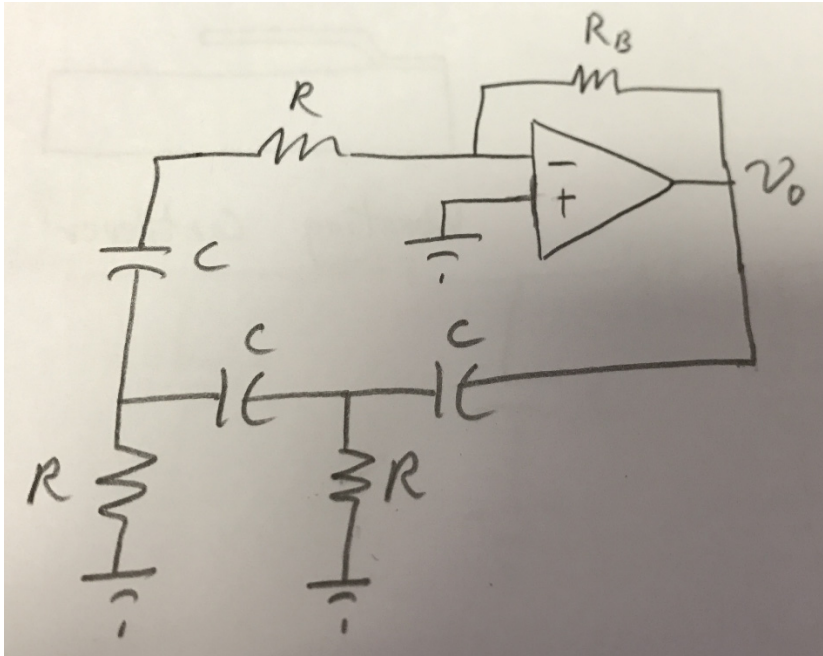

Design procedure:

- (1) Select oscillation frequency and amplitude desired.
- (2) Select the op amp. Note: gain of -29 limits op amp selection based on desired frequency GBW product.  
Example with a 10 MHz GBW op amp: closed loop 3dB BW: 344.8 KHz.  
10% of that is 34.48 KHz
- (3) Select values for R and C.
- (4) Size  $R_B$  to obtain needed gain of -29