

## **A SIMULATION METHODOLOGY FOR ONLINE PROCESS CONTROL OF HOT MIX ASPHALT (HMA) PRODUCTION**

Ozgur Kabadurmus  
Onkar Pathak  
Jeffrey S. Smith  
Alice E. Smith

Haluk Yapicioglu

Department of Industrial and Systems Engineering  
Auburn University, Auburn, Alabama 36849, USA

Department of Industrial Engineering  
Anadolu University, Eskisehir, 26480, TURKEY

### **ABSTRACT**

The quality of hot mix asphalt (HMA) is directly related to the quality of the input aggregates and the control of the production process. Many factors such as aggregate gradation and moisture level affect the quality of hot mix asphalt. As state agencies dictate certain standards on quality of the product, some quality assurance techniques have been used in HMA plants. In the current practice, a production sample is taken and analyzed in the lab. The lab analysis takes approximately two hours, making it difficult to quickly correct production mix problems. In this paper, a new online process control of asphalt production system designed to overcome this problem is described. In the proposed system, an image processing system continuously analyzes images of the samples and the required corrective action is taken instantly by a computerized optimization system. In this paper, the simulation model of the proposed online process control system is presented and the results are discussed.

### **1 INTRODUCTION**

Hot Mix Asphalt (HMA) production is generally subcontracted to the HMA producers by state DOT (departments of transportation) and the Federal Highway Agency (FHWA). As a control procedure, these government institutions investigate the performance of the final asphalt product and determine the *pay factor* (Russel et al., 2001), which ultimately determines the amount of payment to the subcontractor. Not surprisingly, one of the main elements of the pay factor determination is the quality of the asphalt. Schmitt et al. (1997) report that quality control costs of a typical asphalt manufacturer are approximately 2% of total HMA construction costs. Nevertheless, as inferior quality asphalt products may lead to repaving of a road, the actual quality costs would be higher where mixing, trucking, and paving costs correspond to 38% of total HMA construction costs.

Today's typical asphalt plant is a drum plant (Figure 1 depicts its main elements). Aggregates are temporarily stored at the cold feed bins (to be used in the production), and are released onto the main conveyor in specific amounts as required by the job mix formula (JMF). In general, the JMF is dictated by the state agencies based on the type of project. The aggregate mix is then conveyed to the drum where the mix is heated and bitumen and the other required components are added. Lastly, the finished hot mix asphalt is stored in silos before it is transferred to paving site.

An asphalt producer basically works on a project basis and each project can have different specifications. For example, highway roads and roads in downtown areas require different asphalt

specifications. To meet these specifications, a different JMF is developed for each different product requirement. The main concerns for assuring a good quality product are the asphalt content and gradation requirements. Gradation is calculated as the percent passing values for each sieve. According to industry standards, eight different sieve sizes are used for the JMF requirements.

The quality of the asphalt product is affected by the quality of inputs (aggregates) and the production process. Among those, the consistency of the aggregate gradations and the fluctuations in the moisture levels of aggregates are the most critical. Note that aggregates include sand, stone and other elements that are fed to the system from the cold feed bins. Again, the primary issue for the aggregates is the high variation in their gradation values. Obviously, low variation on the gradation is a desired property for the aggregates. The levels of variation in the gradation of an aggregate vary from supplier to supplier, and even from one lot of aggregates to another of the same supplier. More interestingly, different batches of the same aggregate from the same lot can be different from each other due to storage and pick up conditions. As aggregates are stored (generally) in an open area, weather conditions of the storage area, such as humidity and rain, affect the moisture and gradation of aggregates. Also, picking up the aggregates from the stockpiles (typically huge stockpiles) causes heterogeneous mixtures and variation in gradation of aggregates.

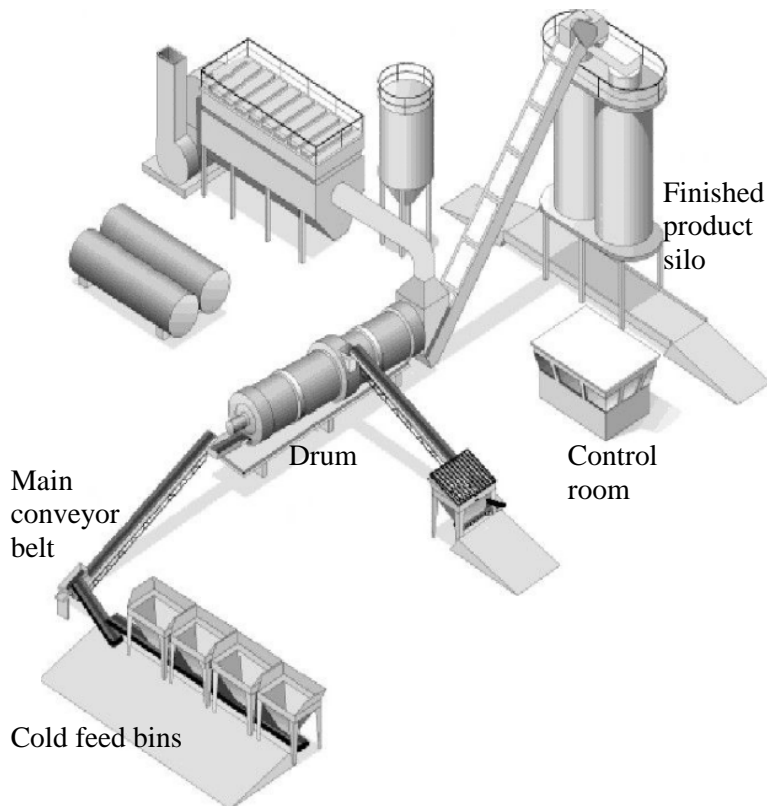

Figure 1: A typical drum asphalt plant (Washington Asphalt Pavement Association Inc, 2002)

The important point is that there is no easy way to change input aggregate quality. A typical quarry (aggregate provider) does not crush their aggregates, rather aggregates are sold as they are. One solution is to crush all aggregates into specific percentages of gradation piles using crusher machines. However, this would be a very costly and time consuming process for both the quarry and the asphalt company. Therefore, variation in aggregate gradation will remain as a problem in the asphalt industry and the most logical option is to admit the variation and improve quality by using another method.

To overcome the above mentioned quality problems, the authors of this paper are currently working on implementing an online process control system that continuously monitors the asphalt production system. In this paper, the simulation component of this online process control system is described. As gradation is the main element for the quality of the asphalt, this paper considers only gradation control. The proposed method is to frequently estimate gradation values via an image analysis system and to use a blending model to determine the proportions of aggregate to use from each bin. Image analysis is a powerful computer-based method for gathering information of aggregate properties (Kuo et al., 1996). Although it is not a common practice in the HMA production industry, some researchers have worked on imaging systems. Kuo et al. (1996) proposed a method to improve the accuracy of gradation estimation by image analysis in HMA production. However, their research is very limited to the size of the particles; fine particles cannot be easily detected (especially #200 sieve, the finest aggregates). Al-Rousan (2005) proposes similar method for image analysis; however, the aggregates are processed separately in this work. West (2005) proposed state-of-the-art equipment that can be used in monitoring HMA production such as, microwave probes (for moisture). In his study, video imaging techniques are mentioned as near future technology.

In this paper, the main assumption is that variation on the gradation of the input aggregates cannot be eliminated. Nevertheless, the variation on the gradation of the final asphalt production can be minimized by finding the optimal percentage contribution from each bin using a blending mix model to improve quality. Here, a new online process control system for HMA production is proposed and a simulation model of this system is presented.

The paper is organized as follows: Section 2 defines the problem, Section 3 presents the proposed method, Section 4 gives the detail of the simulation model and Section 5 summarizes the optimization model. Experimental results are provided in Section 6, followed by conclusion and future work in the last section.

## **2 PROBLEM DEFINITION**

The current practice in industry for assuring the quality of asphalt uses offline quality control methods. A sample is taken from production, and then it is analyzed in the lab to assess the gradation of the product, which should be consistent with the requirements specified in JMF. The analysis process in the lab typically lasts for two hours. If the results of the lab analysis point to a problem, corrective action is taken by an operator.

This long processing time sometimes results in product with poor quality. Not surprisingly, the asphalt company faces some costs related to this poor quality product. These costs can be either direct penalty by state agencies, or milling (removing the asphalt) and re-paving the road with required quality asphalt. In addition, when an asphalt producer makes a superior quality asphalt, state agencies pay a premium to the company (opposite of a penalty). There are other direct costs as well. For instance, consider that a typical asphalt producer has a production rate of 300 tons/hr. Due to the offline nature of the current quality assurance methods, by the time a quality problem is detected, 600 tons of production could have already been made and all this product is potential waste. Asphalt aggregates are melted in a high temperature “drum process”, therefore the energy cost is a main element of the overall manufacturing cost. There is another cost, which is related to transportation of the asphalt and paving the road. The asphalt product should be directly used to pave the road, otherwise the required temperature cannot be met and quality of the road will be decreased. For these reasons, the two hours of analysis time can cause a significant loss to the company.

A common practice in industry is that even though lab results show poor quality, the asphalt is paved on the road. The motivation behind this is that the state agencies check the product of the asphalt using sampling techniques, and there is a chance that they cannot detect the poor quality asphalt product with 100% accuracy. In short, there are important costs due to poor quality asphalt and current systems have a significant time lag between occurrence and detection of the problem.

### 3 PROPOSED METHOD

In this paper, a new process control method is proposed. This method is designed to eliminate the long analysis time in the lab. By doing so, the required corrective action can be taken early.

Figure 2 explains this new process control method. In this method, a new and quick image analysis technique is proposed as opposed to time consuming lab analysis. On the conveyor belt, images of the aggregates are taken continuously (e.g., in every 10 seconds). Then a computerized image process algorithm estimates the gradation of those aggregates before production. Recall that aggregate gradations cannot be changed (those are the production inputs) and they are highly variable. Overall quality of the asphalt is directly related to those gradation values. If the gradation levels of the asphalt are not within the specification limits as dictated by the JMF, the system is out of control. In this case, corrective action is taken to improve quality by changing the percentage of aggregates in the overall mix. The percentages of the aggregates coming from different bins are changed by the optimization blending model (explained in subsequent sections). By continuous re-blending of the mix, the gradation requirements of the final product will be kept as close as possible to the specifications dictated by the JMF. Note that there is no considerable time lag between the calculation of the input gradations, re-blending of the mix and taking corrective action. All of the operations are computerized and there is no human interaction required. On the physical part, after the new blend mix is calculated, this information will be passed to the control software of the asphalt production system. Then the mix will be changed using the physical aggregate bin openings and their conveyor belt speeds.

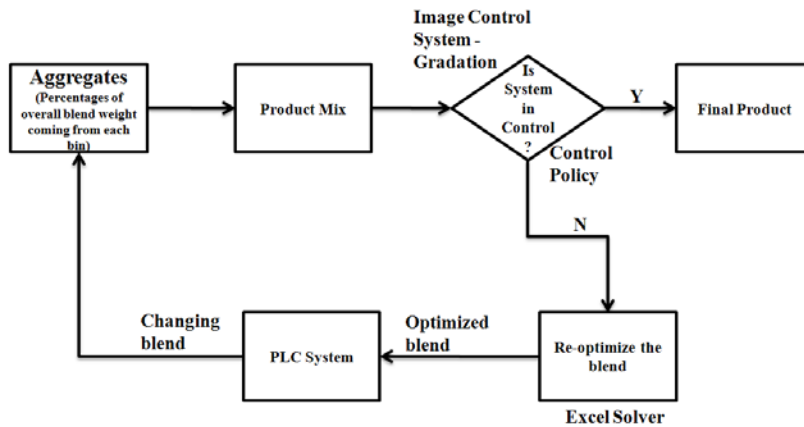

Figure 2: Integration of physical system with Excel Solver

### 4 SIMULATION MODEL

In this paper, a simulation model of the proposed online process control system is described. The main objective of the simulation model is to set parameter values of the actual system. As known, changing system parameters in real practice can be costly. Nevertheless, simulation is a perfect tool for evaluating parameter values. The robustness of the system can be tested using different scenarios, what-if type analyses can be done and fine tuning of parameters can easily be made.

The other benefit of the simulation model is to validate that the proposed online process control system is better than traditional practice. Additionally, this model is a superior way to convince industry to switch their current quality control practices to the proposed online process control system.

The simulation is modeled in Arena 12.0. Additionally, the model works with an MS Excel file. In this file, the inputs of the simulation model are contained. Those input parameters are the mean and standard deviation of the gradation (percent passing) of each sieves for all aggregates, and JMF constraints. One of the simplifying assumptions of the model is that only four sieves are taken into

account instead of all (eight) sieves. These four sieves are the most influential ones (including #200 sieve) as revealed by the preliminary analysis (regression analysis using real data from HMA producers). The sieves considered are: 3/8 inch, No.8, No.30 and No.200. Although the JMF requirements (constraints) will be explained in the next section, they are (a) upper/lower limits of percentages of overall blend weight coming from each bin, (b) upper/lower limits on sieve gradations, and (c) % crushed, friction, and natural sand constraints. The initial values of the percentages of overall blend weight from each bin are read from the Excel file, along with mean & standard deviation of gradation values of aggregates, and JMF constraints.

Note that HMA production is a continuous production in real world. However, the simulation of the system is modeled as a discrete event model. Many applications of the discretization of continuous systems are presented in the literature. Among them, Fioroni et al. (2007) discretized an ore conveyor transport system. Their system is very similar to the main conveyor belt which is used in hot mix asphalt production. They called the discretized units “blocks” and calculated their weight by using the distance covered on the conveyor. The velocity of the conveyor is considered in their case. In our paper, the idea of discretizing the continuous flow on the conveyor is adopted. The main reason of this is that modeling the system continually needs certain equations of flow and they are not easy to extract. On the other hand, using a discretized model of the system allows more flexibility in the model. Note that the system is discretized in time (for material flow and processes), and hypothetically if the discretization time units are small enough (approaching zero) the model resolution will be higher and it will behave close to the continuous model. In this study, one minute has chosen as the discretization time unit.

Discretization works as the discretized chunks of aggregates are created individually as entities to be combined and built up to a discretized final product chunk. To illustrate, if the discretization time is 15 seconds, weights for 15 seconds of the aggregate are created as the entities. The final product will be weighed accordingly.

As the general framework (Figure 3) suggests, first the input data is read from the Excel file. Then the simulation model starts to run, and at this point a trend function starts to work. The trend function is an important tool used in the simulation, and it helps to mimic the real world conditions. In this model, the gradation levels of aggregate 1 stay at the original values (as read from the input file), then increase, and then decrease to a certain mean. This represents the variation of the gradation of the aggregate. As explained before, this situation can be caused by variations in stockpile, different sources of aggregates, or weather conditions. This trend function makes the model behave similarly to the real world.

The input gradations are read from the Excel file and gradations are sampled from a Normal distribution (with a specified mean and variance). This sampling process represents the image analysis system, and the data generated from sampling is the gradations of the aggregates. The assumption made here is that the gradation values obtained by the image process are 100% correct. This assumption must be relaxed in a real life application, but for simulation purposes gradation values are assumed to be precisely correct.

The main question is “Is the system in control?”. The concept of “in control” is defined by the control policy used in the simulation. There are two different control policies used in the simulation (besides the no control policy case):

- Control 1: If any overall gradation of any sieve goes beyond the control limits (specified by the JMF) the % of aggregate contributions of bins are re-optimized.
- Control 2: If any overall gradation of at least two sieves go beyond the control limits (specified by the JMF), the % of aggregate contributions of bins are re-optimized.

These control policies work according to the moving average of the sieve gradations. As variability in the inputs can cause natural spikes in the gradation, detection of a sudden and temporary shift may not be the best option. By using moving average the persistent shifts in the process can be detected easily. In this paper, the moving average of the last four values (including the current value) is used. This number is

selected according to the preliminary analysis results. Nevertheless, many other control policies can be introduced and these three are only representative.

As the entities are created according to the predefined discretization time interval, the final product is checked for the control rule which is applied at each time interval. If the final product chunk is “in control”, then there is no need for changing the blend. On the other hand, if the final product is out of control, then corrective action is taken. The corrective action is to re-optimize the blend. Recall that the control rule operates on the moving average of sieve gradations. As an input, actual gradation values of each sieve of the aggregates are read from Arena and written to Excel as inputs for the optimization model. Upon obtaining the new % values of aggregates using the optimization model, those new values (i.e., the blend) are read from Excel and written back to Arena, and the simulation run continues with the new blend values. The simulation continues to run until the specified termination criterion is met, which is 10 hours of simulation time in this paper.

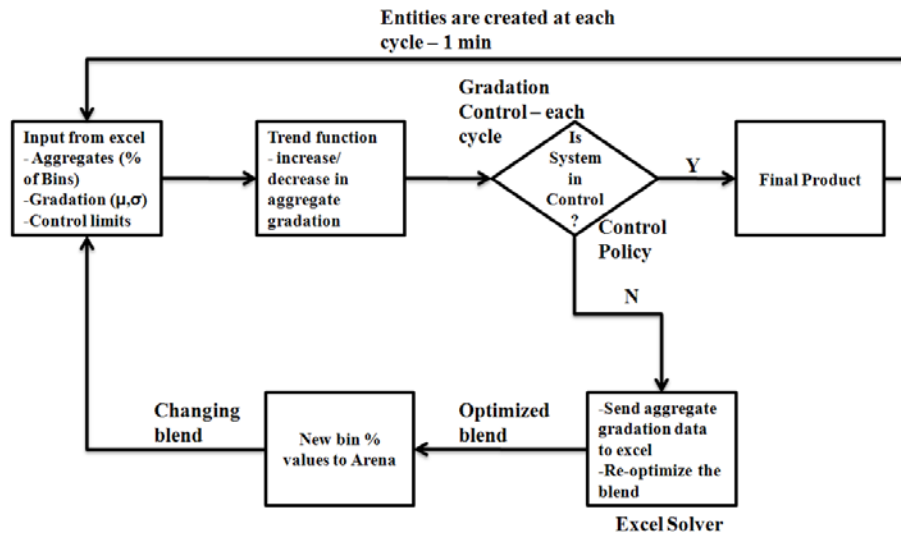

Figure 3: Integration of simulation model with Excel solver

In the following paragraph, the “time lag” concept of the simulation is explained (Figure 4). Recall that all aggregates are stored in bins, and they are poured to the main conveyor from those bins. From both a real life application and a simulation perspective, conveyor speed is important for combination of the aggregates. Suppose the distance between any two bins is the same; then, travel time from bin  $i$  to bin  $(i+1)$  is exactly same (where  $i = 1,2,3,4$ ). The problem is; if a final product (discretized unit) is detected as out of control and the percentage values of the aggregates are re-optimized, then the issue to be addressed becomes “how the blend change will be applied to the bins?”. If the percentages of all bins are changed at once, variations in the overall weight of the final product will result. Assume a scenario in which the blend is re-optimized at time  $T$ . If all percentages are changed at the same time, at time  $T$  only the bin 5 percentage will be the new one, and bins 1 to 4 will remain the old percentages (weights). Therefore, the total weight of the final product can no longer be stabilized to 300 tons/hr (a predefined parameter, production capacity). Even more importantly, the percentages of the aggregates will be neither the old percentages nor the new percentages, because overall weight is changed. To overcome this problem, the blend must be changed sequentially. First, bin 1 must be changed (because it is farthest to the drum), after  $t$  time units bin 2 is changed and met with the aggregate 1 on the conveyor. Bins 3 and 4 are changed in similar fashion; bin 5 must be changed  $4t$  time units after the change of bin 1. Therefore, in the simulation this time lag concept is applied and  $t$  is selected as 15 seconds.

In simulation, another important concept of time lag is handled. Obviously,  $4t$  time units are required for changes to take effect after re-optimization and during that time any out of control point has already

been corrected with the optimization. In that, during this 4t time interval Solver is not initiated to prevent redundant aggregate mix changes.

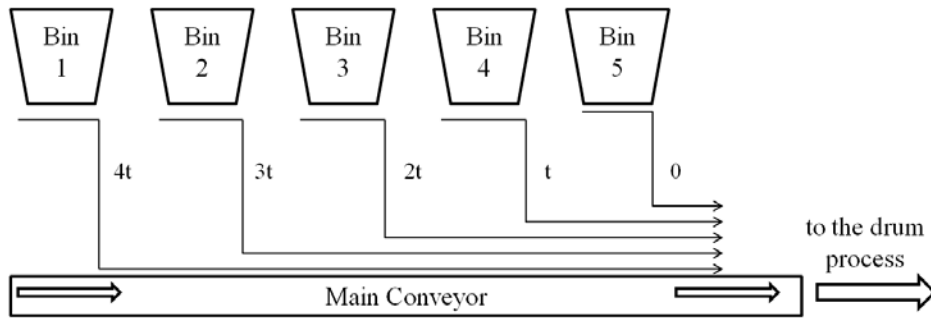

Figure 4: Time lag demonstration for blend re-optimization

The Arena simulation model consists of four main parts: sampling of input variable values, sieve gradation calculations, optimization, actual bin-sieve gradation read/write and bin opening values calculation. In the first part, the input gradations are sampled from the mean and variance values that are read from the Excel file. Then sieve gradations are calculated by combining the individual bin/sieve gradations. Actual bin/sieve gradation values are written to Excel before the Solver optimization. After optimization, new blend mix values are written to the simulation model and bin opening values are calculated in the simulation. Those main parts are presented in Figure 5 below.

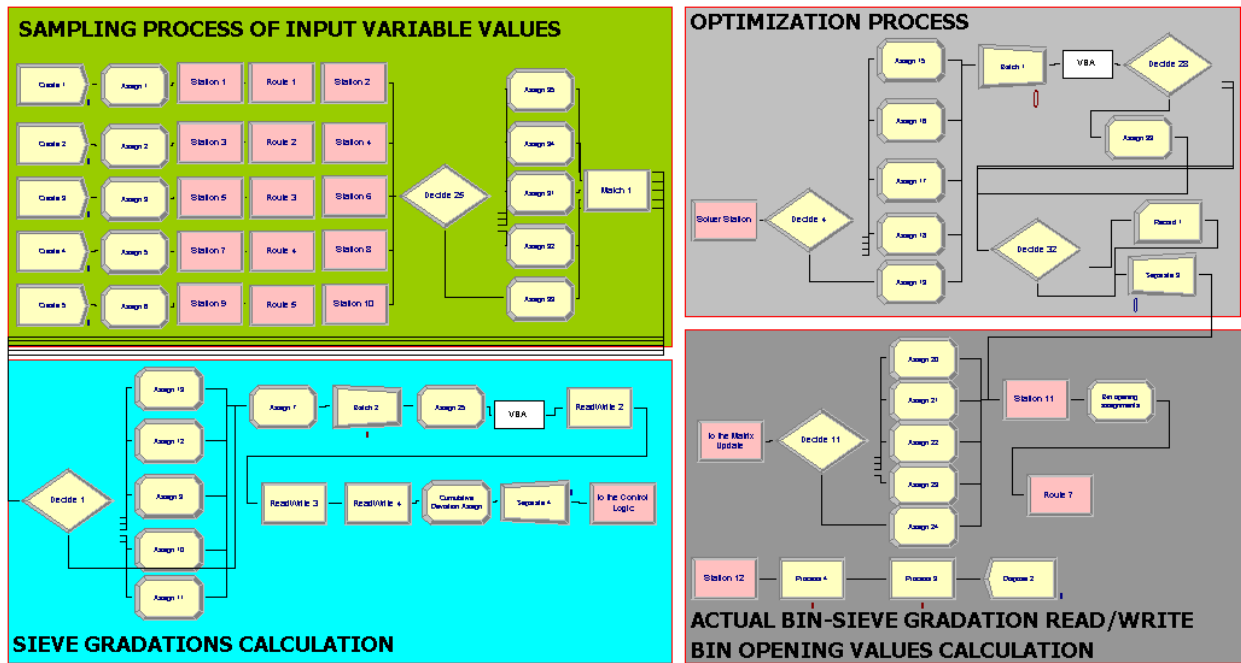

Figure 5: The main parts of the simulation

In addition to the above main parts, there is a control logic part in the simulation model. This control logic decides the out of control points in the process and initiates the Solver. User input is required at the beginning of the simulation to select a control policy, and the control logic is applied according to that selection. This part of the simulation is depicted in Figure 6.

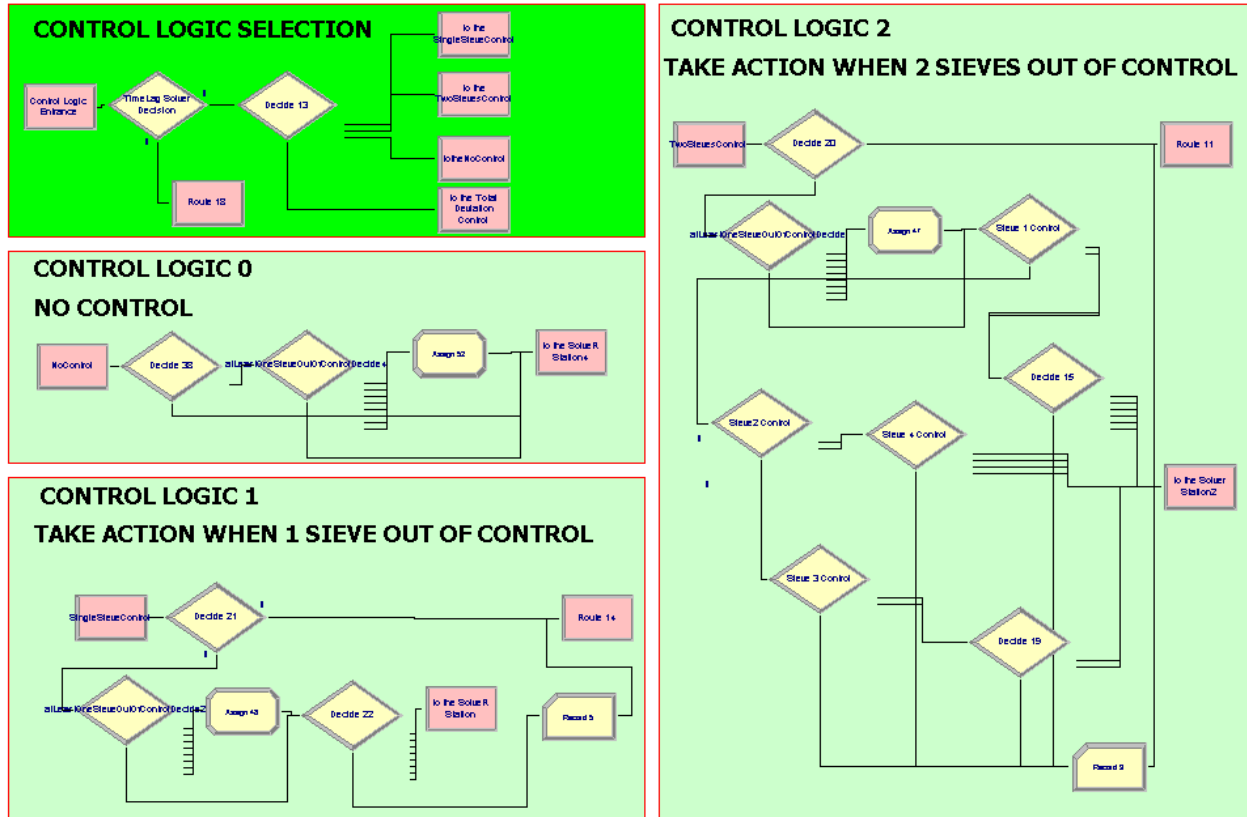

Figure 6: Control logic of the simulation

The typical animation of the simulation model is given below in Figure 7. On the left side of Figure 7, a control chart of moving average of sieve gradation is shown including the upper and lower control limits. In addition, the figure shows the input gradation of Bin1Sieve1 and % weight of bin 1. On the right side, percentage of weight of bin 1 is presented. These figures are the major animations in the simulation. As these figures explain the variability and the effect of control policy, it is very helpful to demonstrate the benefits of the proposed system.

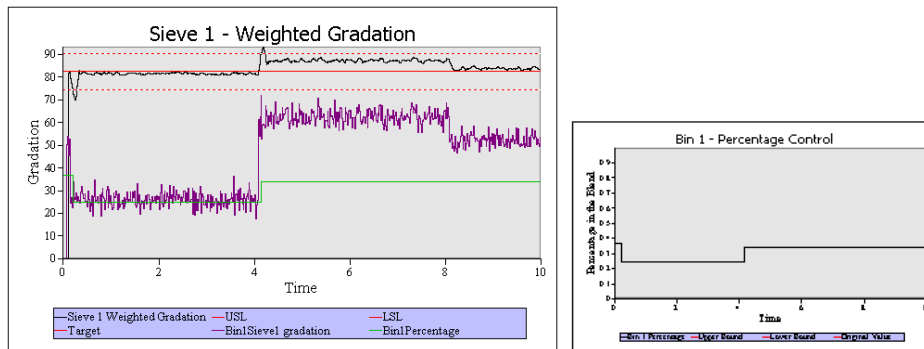

Figure 7: The typical animation of the simulation

## 5 OPTIMIZATION MODEL

As explained in the previous section, the simulation model is integrated with an optimization model. This optimization model is initiated when the system is out of control and it optimizes the percentages of

aggregates in the overall mix. In this study, Excel solver is used for the optimizer. The main elements of the optimization model are presented below.

The decision variable in the model is:

- Percentages of overall blend weight coming from each bin ( $x_i$ )

The parameters are:

- Gradation measurements from bins ( $g_{ij}$ )
- Target levels (by JMF) for % passing the sieves ( $n_j$ )
- Upper and lower spec limits for % passing the sieves ( $r_j^{\min}, r_j^{\max}$ )
- Upper and lower limits for % weight coming from each bin ( $b_i^{\min}, b_i^{\max}$ )
- Minimum and maximum limits on % crushed, friction and natural sand  $c_p^{\min}, c_p^{\max}$  ;  $p=\%$  (crushed, friction and natural sand)
- Aggregate properties for each bin: % crushed, friction and natural sand  $a_{ip}$  ;  $p=\%$  (crushed, friction and natural sand)

The model is formally stated as:

$$\min \sum_j t_j \quad (1)$$

s.t.

$$t_j = \frac{\left| n_j - \sum_i x_i g_{ij} \right|}{(r_j^{\max} - r_j^{\min})/2} \quad (2)$$

$$r_j^{\min} \leq \sum_i x_i g_{ij} \leq r_j^{\max} \quad (3)$$

$$b_i^{\min} \leq x_i \leq b_i^{\max} \quad (4)$$

$$c_p^{\min} \leq \sum_i x_i a_{ip} \leq c_p^{\max} \quad (5)$$

$$\sum_i x_i = 1 \quad (6)$$

$$x_i \geq 0 \quad (7)$$

The objective of the model is to minimize total deviation from target gradations over all sieves. Equation (2) calculates the normalized deviation for each sieve. Normalized deviation is the deviation of gradation from the target as a percentage of the half range of spec limits. Constraint (3) is the constraint of upper and lower control limits of the gradations of sieves. Upper and lower limits of the bin percentages are stated in constraint (4). % crushed, friction and natural sand constraints are stated in constraint (5). The summation of all the aggregate percentages must be 1, and each of them must be nonnegative as are stated in (6) and (7).

Obviously, more loose constraints allow the model to find better solutions. In contrast, tighter constraints make the model to find poor solutions. Recall that all constraints depend on the job mix formula requirements. Nevertheless, loose constraints enable more robust solutions to the natural variations of inputs, and tight constraints are more prone to the effects of the natural variations of the inputs. Obviously, high shifts in the gradation (such as a trend function in the simulation) will affect both cases, but the latter case is expected to be affected more.

## 6 EXPERIMENTAL RESULTS

The simulation model is tested by various scenarios as given below:

- Low variation in input gradation (Base case scenario)
- High variation in input gradation
- Tight constraints (with low variation in input gradation)
- Tight constraints (with high variation in input gradation)

The reason that these scenarios are selected is that the model robustness depends on the variation of input gradation and the tightness of the JMF requirements (constraints). All values of input parameters are selected arbitrarily. Results are obtained by single run of 10 hours, which corresponds to one working day of a typical asphalt manufacturer. Only one replication per scenario is considered for these preliminary results, and more runs will be performed as a future study. The results are summarized in Table 1.

Table 1: Number of times that the blend is re-optimized (number of off target products)

	<b>No Control</b>	<b>Control 1</b>	<b>Control 2</b>
Low Variation	410 (0 - 0) 1157.45 *	2 (2 - 0) 562.10	410 (0 - 0) 1157.45
High Variation	376 (0 - 0) 1177.38	2 (2 - 0) 667.05	376 (0 - 0) 1177.38
Tight Constraints (with low variation)	418 (0 - 0) 1500.10	4 (4 - 0) 727.40	361 (1 - 0) 1485.17
Tight Constraints (with high variation)	593 (0 - 0) 2284.46	42 (42 - 6) 1453.94	82 (4 - 0) 1275.02

\* # out of specification limits (# Solver initiated - # no solution)  
Total cumulative deviation from all sieves

In Table 1, “Number of out of specification limits” corresponds to time, i.e. how long (in minutes) the system was in out of specification limits where the maximum is 600 minutes (10 hours of simulation time). “Number of solver initiated” indicates that the number of instances where the system was out of control according to the selected control policy. “Number of no solution” gives the number of instances out of total number of solver initiations in which the optimization model could not find a feasible solution. “Total cumulative deviation from all sieves” is the summation of deviation values (over time) of all sieves where Equation (3) defines deviation as a percentage deviating from target gradation value of the corresponding sieve.

The most striking result is that online process control decreases the number of “# out of specification limits” and improves quality. This result shows the effectiveness of the proposed methodology. The second observation is that the variation in the input gradations and tight requirements of JMF reduces the quality. Not surprisingly, the “low variation” case results in the least number of off target products. Another observation is that control 1 has interrupted the process and re-optimized the mix more than control 2. The reason for this is obvious; control 2 waits for at least two sieves to be out of control, whereas control 1 re-optimizes the mix when one out of control sieve is observed. The final remark is that the tighter constraints with high variation scenario yields the worst results. Accordingly, in 6 out of 42 optimization model initiations, Solver could not find any feasible solutions, and for all control policies the total normalized deviation values are dramatically higher than the other scenarios. The reason of this result is that this scenario has both high input gradation variation and tight JMF constraints, so it is not surprising to get inferior quality.

A typical animation of the simulation for the low variation control 1 case is shown in Figure 8. In this figure, all results of the simulation are presented: how many times the mix was out off the specification

limits, how many times the blend has changed, how many times there was no feasible solution, normalized deviation of each sieve and the total of all the sieves.

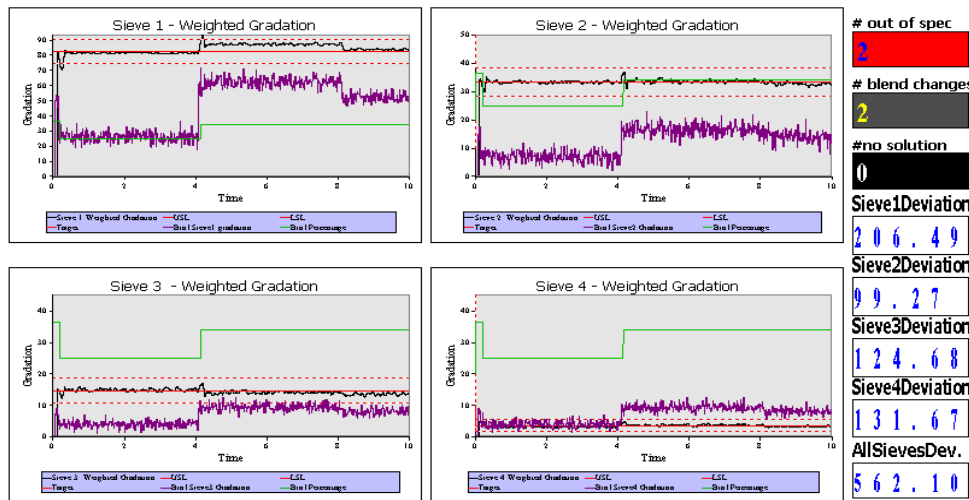

Figure 8: Screen shot of simulation output for low variation control 1 scenario

## 7 CONCLUSIONS AND FUTURE WORK

In this study, an alternative to the current practice of asphalt quality control is presented. The current practice takes approximately two hours to detect out of control situations and take corrective action. In the proposed online process control system, the system state is continuously monitored and corrective action is taken immediately. To do this, an image analysis system is proposed and an optimization model used to change the optimal percentages of the mix when the system is detected to be ‘out of control’. The image analysis system estimates the gradations of each aggregate and sends those data to the computer. If the gradations are within the specified limits, there is no need to change the aggregate mix. Otherwise, the mix is re-optimized and the system continues to produce with the new mix values.

The simulation model is designed to mimic this online process control system. It is a tool to convince asphalt producers of the benefits of this new system. In addition, different scenarios can easily be tested and parameter values can be set to optimum values. Particularly, different control policies can be tested and the most appropriate one can be selected.

The results of the experiments show that variation and tight job mix formula requirements reduce system performance. However, the effectiveness of the proposed method is also shown by the number of ‘off target’ (poor quality) products. While the results are case dependent, the important point is that the proposed system keeps production in control and reduces the amount of poor quality products.

As future work, the benefits of the proposed system in terms of monetary value will be calculated. This is essential to show the benefits of the online process control system to industry. Even more importantly, the proposed system will be implemented in a real asphalt production system. Implementation is a challenging process because it also includes the validation of the proposed system. During the implementation process some minor modifications in the online process control system are expected, such as implementation of a different control policy, or a different interval time of image processing.

## ACKNOWLEDGMENTS

This study was supported by a grant from the Federal Highway Administration: DTFH61-05-H-00002-AU 8-D3-ISE; Dr. Jeffrey S. Smith from Dept. of Industrial and Systems Engineering and Dr. Michael Heitzman from NCAT (National Center for Asphalt Technology) at Auburn University are the PIs on the grant.

## REFERENCES

- Al-Rousan, T., Masad E., Myers, L., Speigelman, C. 2005. New Methodology for Shape Classification of Aggregates. *Journal of the Transportation Research Board* 1913: 11-23.
- Fioroni, M. M., Franzese, L.A.G., Zanin, C.E., Fúria, J., Perfetti, L.T., Leonardo, D., Silva, N.L. 2007. Simulation of Continuous Behavior Using Discrete Tools: Ore Conveyor Transport. In *Proceedings of the 2007 Winter Simulation Conference*, ed S. G. Henderson, B. Biller, M.-H. Hsieh, J. Shortle, J. D. Tew, and R. R. Barton, pp. 98 – 103, OMNIPRESS, MADISON, WI.
- Kuo, C.Y., Frost, J.D., Lai, J.S., Wang, L.B. 1996. Three-Dimensional Image Analysis of Aggregate Particles from Orthogonal Projections. *Journal of the Transportation Research Board* 1526: 98-103.
- Russell, J.S., Hanna, A.S., Nordheim E.V., Schmitt, R.L. 2001. Testing and Inspection Levels for Hot-Mix Asphaltic Concrete Overlays. National Cooperative Highway Research Program NCHRP REPORT: 447.
- Schmitt, R.L., Hanna, A.S., Russell, J.S. 1997. Improving Asphalt Paving Productivity. *Journal of the Transportation Research Board* 1575: 23-33.
- Washington Asphalt Pavement Association Inc, 2002. Interview with J. K. Rowling. Available via WAPA Asphalt Pavement Guide. [http://www.asphaltwa.com/wapa\\_web/index.htm](http://www.asphaltwa.com/wapa_web/index.htm) [accessed January 5, 2010].
- West, R. 2005. Development of Rapid QC Procedures For Evaluation of HMA Properties during Production. NCAT Report 05-01.

## AUTHOR BIOGRAPHIES

**OZGUR KABADURMUS** is a Research Assistant and Ph.D. student at Dept. of Industrial and Systems Engineering, Auburn University. He received the B.S. and M.S. in Industrial Engineering from Istanbul Technical University, Turkey in 2005 and 2008, respectively. His main research areas are the analysis and design of production systems, simulation, and applied operations research/metaheuristic optimization.

**HALUK YAPICIOGLU** is an Assistant Professor in the Dept. of Industrial Engineering at Anadolu University, Eskisehir Turkey. He received his B.S. in Industrial Engineering from Anadolu University, Eskisehir, Turkey in 1997, M.S. in Industrial Engineering from Middle East Technical University, Ankara, Turkey in 2001, and Ph.D. in Industrial Engineering from Auburn University in 2008. Dr. Yapicioglu's research interests include facility layout and location, the use of evolutionary computation techniques in modeling and optimization and simulation modeling and analysis of manufacturing systems.

**ONKAR PATHAK** is a Research and Teaching Assistant and Master's student at Dept. of Industrial and Systems Engineering, Auburn University. He received Bachelor's degree in Production Engineering from Vishwakarma Institute of Technology, Pune, India in 2007. He wishes to work to work in the field of process improvement.

**JEFFREY S. SMITH** is a Professor at Dept. of Industrial and Systems Engineering, Auburn University. He received the B.S. in Industrial Engineering from Auburn University in 1986 and the M.S. and Ph.D. degrees in Industrial Engineering from Penn State University in 1990 and 1992, respectively. Professor Smith's research interests involve the modeling and analysis of manufacturing systems, applications of discrete event simulation, and general modeling and analysis.

**ALICE E. SMITH** is a Professor at Dept. of Industrial and Systems Engineering, Auburn University. Professor Smith's research interests involve the modeling, analysis and optimization of complex manufacturing and engineering design systems using computational intelligence (artificial neural networks, meta-heuristics and fuzzy systems) combined with techniques from probability and statistics and from operations research. Primary application areas include manufacturing process control, advanced materials microstructure, design for reliable networks, facilities design and economic modeling.