

8A

A walkway from a pier to a floating dock has a roller at point A and rests on a roller at point B. In addition, there is a cable attached to the walkway from the pier. The walkway weighs 3000 N and the center of gravity is at point G.

- Draw a FBD of the walkway.
- Determine the reaction forces acting on the walkway at points A and B.
- Determine the force that the cable exerts on the walkway at point B.
- Write the reaction forces as Cartesian vectors. (Use correct directions)

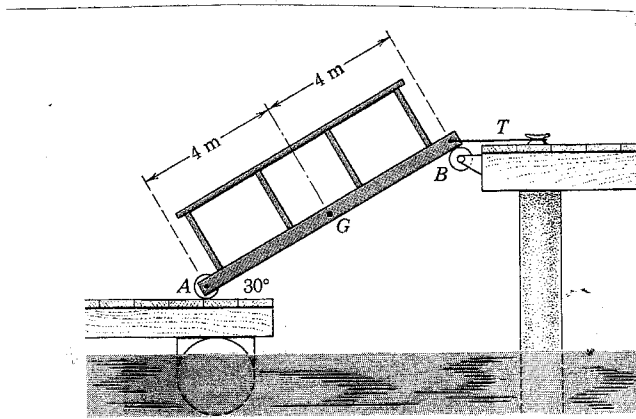

8B

The "L" bracket shown below is welded to wall at point A.

- Draw a FBD of the bracket.
- Determine the forces and the moment (reactions) that the wall exerts on the bracket.
- Write the reaction forces and moment as Cartesian vectors. (Use correct directions)

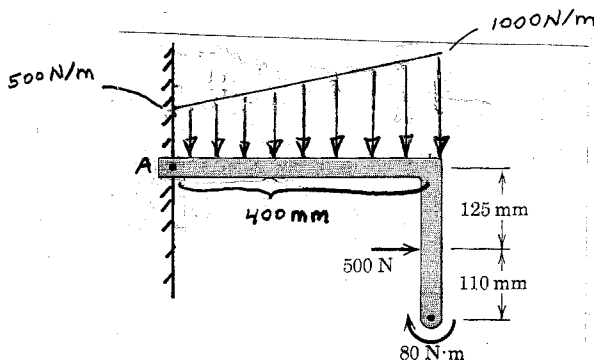

8C A bracket is attached to a movable plate. The bracket is pinned to the plate at point A and fits around a dowel pin at point B (frictionless slot).

- Draw a FBD of the bracket
- Determine the reaction forces at points A on B that act on the bracket.
- Write the reaction forces as Cartesian vectors. (*use correct directions*)

