

5-3. Draw the free-body diagram of the beam supported at A by a fixed support and at B by a roller. Explain the significance of each force on the diagram. (See Fig. 5-7b.)

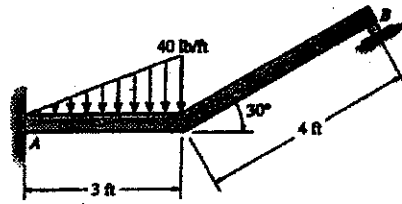

A_x, A_y, M_A effect of wall on beam.

N_B force of roller on beam.

60 lb resultant force of distributed load on beam.

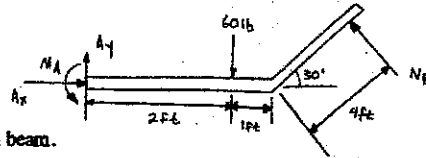

5-4. Draw the free-body diagram of the jib crane AB , which is pin-connected at A and supported by member BC .

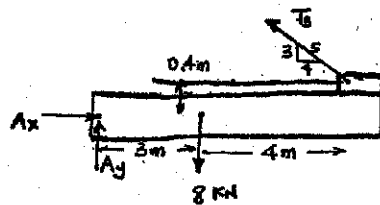
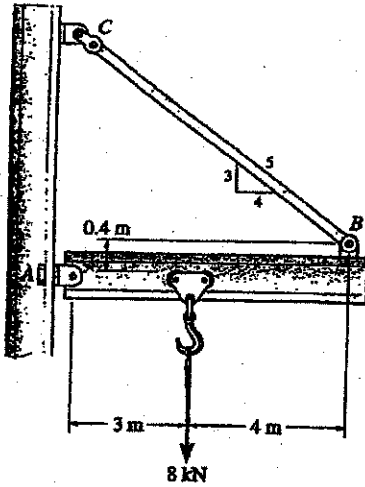

7.19 Determine the magnitude of the reactions on the A and B. Neglect the thickness of the beam.

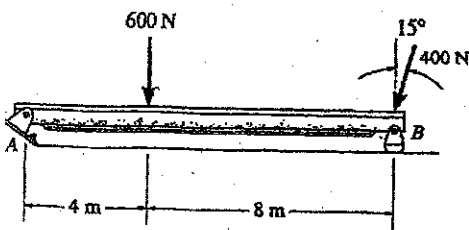

$$+\circlearrowleft \Sigma M_A = 0; \quad B_y (12) - (400 \cos 15^\circ)(12) - 600(4) = 0$$

$$B_y = 586.37 = 586 \text{ N} \quad \text{Ans}$$

$$\rightarrow \Sigma F_x = 0; \quad A_x - 400 \sin 15^\circ = 0$$

$$A_x = 103.528 \text{ N}$$

$$+\uparrow \Sigma F_y = 0; \quad A_y - 600 - 400 \cos 15^\circ + 586.37 = 0$$

$$A_y = 400 \text{ N}$$

$$F_A = \sqrt{(103.528)^2 + (400)^2} = 413 \text{ N} \quad \text{Ans}$$

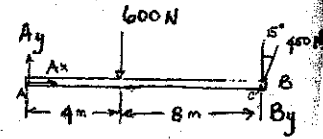

7.20 Determine the reactions at the supports.

$$\Sigma F_x = 0; \quad A_x = 0 \quad \text{Ans}$$

$$\Sigma M_A = 0; \quad 750(8) - (6)B_y = 0$$

$$B_y = 1000 \text{ lb} \quad \text{Ans}$$

$$+\uparrow \Sigma F_y = 0; \quad A_y - 3750 + 1000 = 0$$

$$A_y = 2750 \text{ lb} \quad \text{Ans}$$

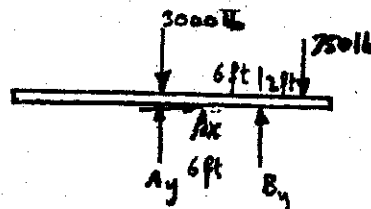
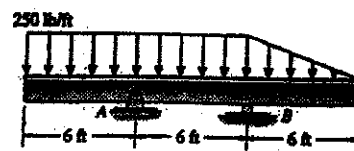

5-39. The worker uses the hand truck to move material down the ramp. If the truck and its contents are held in the position shown and have a weight of 100 lb with center of gravity at G , determine the resultant normal force of both wheels on the ground A and the magnitude of the force required at the grip B .

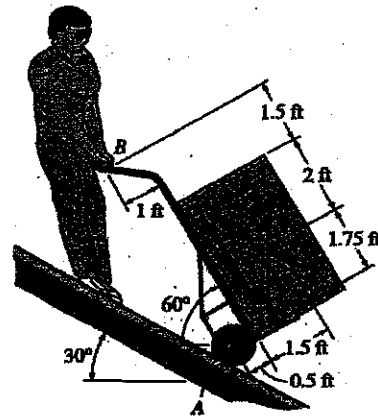

$$\curvearrowleft + \Sigma M_B = 0; \quad (N_A \cos 30^\circ)(5.25) + N_A \sin 30^\circ(0.5) - 100 \sin 30^\circ(3.5) - 100 \cos 30^\circ(2.5) = 0$$

$$N_A = 81.621 \text{ lb} = 81.6 \text{ lb} \quad \text{Ans}$$

$$+\searrow \Sigma F_x = 0; \quad -B_x + 100 \cos 30^\circ - 81.621 \sin 30^\circ = 0$$

$$B_x = 45.792 \text{ lb}$$

$$\nearrow + \Sigma F_y = 0; \quad B_y - 100 \sin 30^\circ + 81.621 \cos 30^\circ = 0$$

$$B_y = -20.686 \text{ lb}$$

$$F_B = \sqrt{(45.792)^2 + (-20.686)^2} = 50.2 \text{ lb} \quad \text{Ans}$$

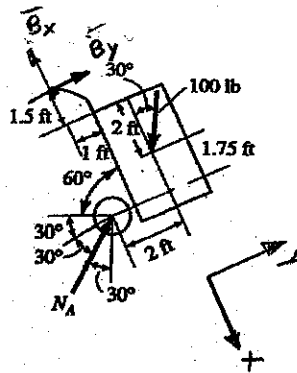

5-41. The shelf supports the electric motor which has a mass of 15 kg and mass center at G_m . The platform upon which it rests has a mass of 4 kg and mass center at G_p . Assuming that a single bolt B holds the shelf up and the bracket bears against the smooth wall at A , determine this normal force at A and the horizontal and vertical components of reaction of the bolt on the bracket.

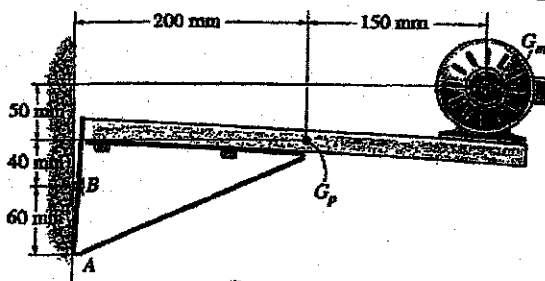

$$\curvearrowleft + \Sigma M_A = 0; \quad B_z(60) - 4(9.81)(200) - 15(9.81)(350) = 0$$

$$B_z = 989.18 = 989 \text{ N} \quad \text{Ans}$$

$$\rightarrow \Sigma F_x = 0; \quad A_x = 989.18 = 989 \text{ N} \quad \text{Ans}$$

$$+\uparrow \Sigma F_y = 0; \quad B_y = 4(9.81) + 15(9.81)$$

$$B_y = 186.39 = 186 \text{ N} \quad \text{Ans}$$

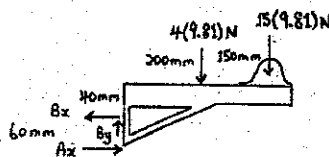

27. The platform assembly has a weight of 250 lb and center of gravity at G_1 . If it is intended to support a maximum load of 400 lb placed at point G_2 , determine the smallest counterweight W that should be placed at B in order to prevent the platform from tipping over.

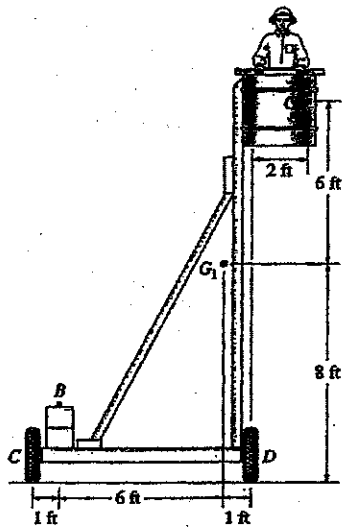

When tipping occurs, $R_C = 0$

$$\sum M_D = 0; \quad -400(2) + 250(1) + W_B(7) = 0$$

$$W_B = 78.6 \text{ lb} \quad \text{Ans}$$

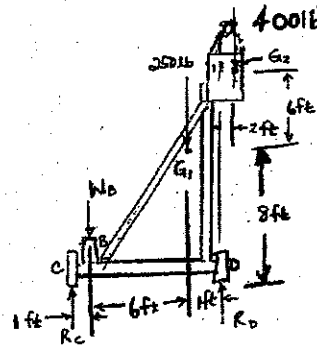

Determine the reactions on the bent rod which is supported by a smooth surface at B and by a collar at A , if the rod is fixed to the rod and is free to slide over the fixed rod.

$$\sum M_A = 0; \quad M_A - 100(3) - 200 + N_B \left(\frac{12}{13}\right)(6) - N_B \left(\frac{5}{13}\right)(2) = 0$$

$$\sum F_x = 0; \quad N_A \left(\frac{4}{5}\right) - N_B \left(\frac{5}{13}\right) = 0$$

$$\sum F_y = 0; \quad N_A \left(\frac{3}{5}\right) + N_B \left(\frac{12}{13}\right) - 100 = 0$$

Ans.

$$N_A = 39.7 \text{ lb} \quad \text{Ans}$$

$$N_B = 82.5 \text{ lb} \quad \text{Ans}$$

$$M_A = 106 \text{ lb} \cdot \text{ft} \quad \text{Ans}$$

