

- 3A. Find the  $\mathbf{i}$ ,  $\mathbf{j}$ , and  $\mathbf{k}$  components for the force shown below using the coordinate system provided.

$$\overline{BA} = (-30-0)\overline{i} + (40-0)\overline{j} + (0-80)\overline{k}$$

$$\overline{BA} = -30\overline{i} + 40\overline{j} - 80\overline{k} \text{ (m)}$$

$$BA = \sqrt{(30)^2 + (40)^2 + (80)^2}$$

$$BA = 94.3 \text{ m}$$

$$\overline{u}_{BA} = \frac{\overline{BA}}{BA}$$

$$\overline{u}_{BA} = .318(-\overline{i}) + .424(\overline{j}) + .848(-\overline{k})$$

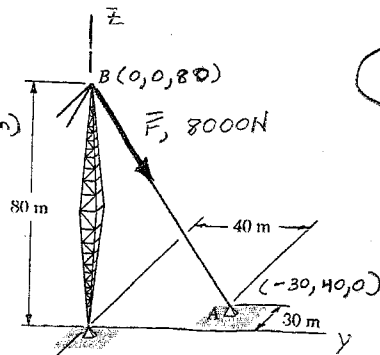

$$\overline{F} = F \overline{u}_{BA} = 8000 \text{ N } \overline{u}_{BA}$$

$$\overline{F} = 2544(-\overline{i}) + 3392(\overline{j}) + 6784(-\overline{k}) \text{ N}$$

- 3B. Find the  $\mathbf{i}$ ,  $\mathbf{j}$ , and  $\mathbf{k}$  components for the force shown below using the coordinate system provided.

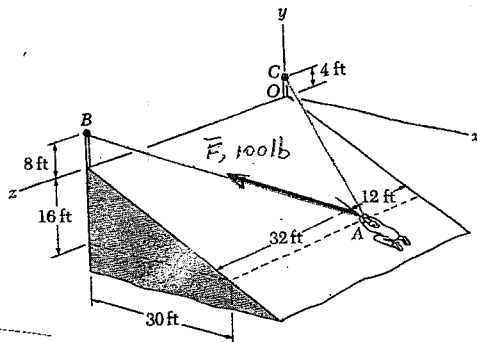

coordinates of point A

$$x = 30 \text{ ft}$$

$$y = -16 \text{ ft}$$

$$z = 12 \text{ ft}$$

coordinates of point B

$$x = 0$$

$$y = 8 \text{ ft}$$

$$z = 44 \text{ ft}$$

$$\overline{AB} = (0-30)\overline{i} + (8-(-16))\overline{j} + (44-12)\overline{k}$$

$$\overline{AB} = -30\overline{i} + 24\overline{j} + 32\overline{k} \text{ (ft)}$$

$$AB = \sqrt{(30)^2 + (24)^2 + (32)^2} = 50 \text{ ft}$$

$$\overline{u}_{AB} = \frac{\overline{AB}}{AB} = -.6\overline{i} + .48\overline{j} + .64\overline{k}$$

$$\overline{F} = F \overline{u}_{AB} = 100 \text{ lb } \overline{u}_{AB}$$

$$\overline{F} = 60(-\overline{i}) + 48(\overline{j}) + 64(\overline{k}) \text{ lb}$$

3C.

Find the  $\mathbf{i}$ ,  $\mathbf{j}$ , and  $\mathbf{k}$  components for the force shown below using the coordinate system provided.

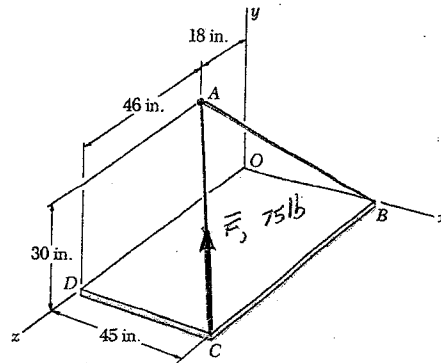

coordinates of point A

$$\begin{aligned}x &= 0 \text{ in} \\y &= 30 \text{ in} \\z &= 18 \text{ in}\end{aligned}$$

coordinates of point C

$$\begin{aligned}x &= 45 \text{ in} \\y &= 0 \\z &= 64 \text{ in}\end{aligned}$$

$$\therefore \vec{CA} = (0-45)\vec{i} + (30-0)\vec{j} + (18-64)\vec{k} \text{ (in)}$$

$$\vec{CA} = -45\vec{i} + 30\vec{j} - 46\vec{k} \text{ (in)}$$

$$CA = \sqrt{(45)^2 + (30)^2 + (46)^2} = 71 \text{ in}$$

$$\vec{u}_{CA} = -.634\vec{i} + .423\vec{j} - .648\vec{k}$$

$$\vec{F} = F\vec{u}_{CA} = 75 \text{ lb}\vec{u}_{CA}$$

$$\vec{F} = 47.6(-\vec{i}) + 31.7(\vec{j}) + 48.6(-\vec{k}) \text{ (lb)}$$