

12A. For the frame shown below,

- determine the forces acting on members ABF and BCD.
- After working part (a), draw FBD's of members ABF and BCD showing the forces acting in their CORRECT directions.

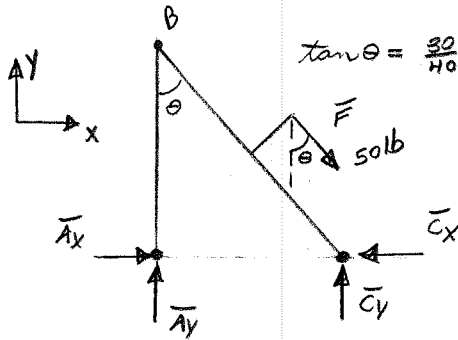
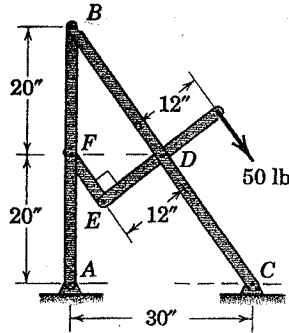

$$\tan \theta = \frac{30}{40} \Rightarrow \theta = 36.9$$

$$\sum \bar{F}_x = 0 = (A_x - C_x + 50 \sin 36.9) \bar{i}$$

$$\sum \bar{F}_y = 0 = (A_y + C_y - 50 \cos 36.9) \bar{j}$$

$$\sum \bar{M}_C = 0 = (-50 \text{ lb} (12) - A_y (30)) \bar{k}$$

$$\therefore A_y = -20 \text{ lb}$$

$$C_y = 60 \text{ lb}$$

a) member EF is a 2FM

b) all members

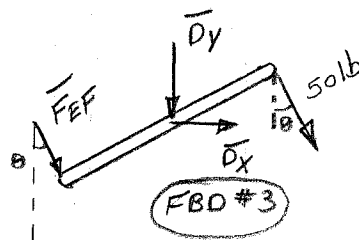
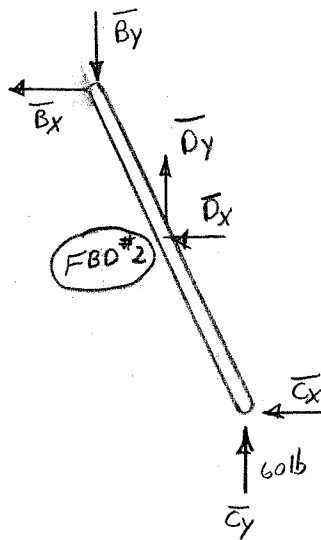
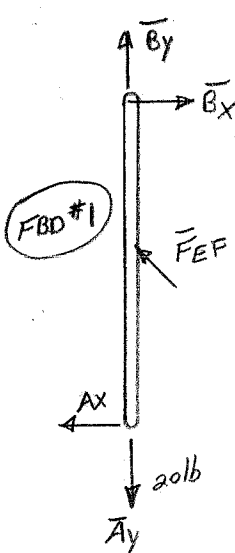

now, FBD #3 is the only one with only 3 unknown forces, so let's start there.

$$\Sigma \bar{F}_x = 0 = (D_x + 50 \sin 36.9 + F_{EF} \sin 36.9) \bar{i}$$

$$\Sigma \bar{F}_y = 0 = (-D_y - 50 \cos 36.9 - F_{EF} \cos 36.9) \bar{j} = 0$$

$$\Sigma M_D = 0 = (-50 \text{ lb}(12 \text{ in}) + F_{EF}(12 \text{ in})) \bar{k} = 0$$

$$\therefore F_{EF} = 50 \text{ lb}$$

$$\therefore D_y = -80 \text{ lb (WD)}$$

$$D_x = -60 \text{ lb (WD)}$$

now, looking at FBD #2, we now only have 3 unknown forces:  $C_x$ ,  $B_x$  and  $B_y$

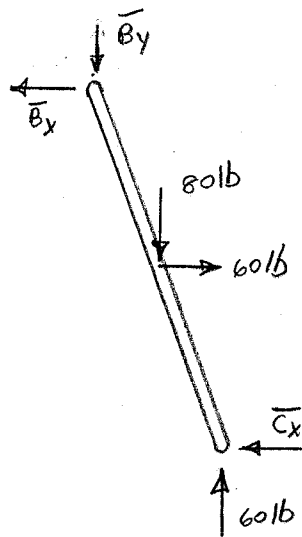

$$\Sigma \bar{F}_x = 0 = (-B_x + 60 - C_x) \bar{i}$$

$$\Sigma \bar{F}_y = 0 = (-B_y - 80 \text{ lb} + 60 \text{ lb}) \bar{j}$$

$$\therefore B_y = -20 \text{ lb (WD)}$$

$$\Sigma \bar{M}_B = 0 = \{-80 \text{ lb}(15 \text{ in}) + 60 \text{ lb}(20 \text{ in}) + 60 \text{ lb}(30 \text{ in}) - C_x(40 \text{ in})\} \bar{k}$$

$$C_x = 45 \text{ lb}$$

$$\therefore B_x = 15 \text{ lb}$$

Finally, looking at FBD #1

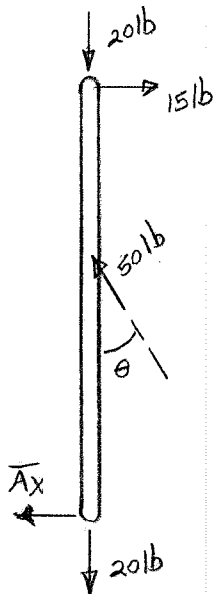

$$\sum \bar{F}_x = 0 = (15 - 50 \sin 36.9 - A_x) \bar{i}$$

$$A_x = -15 \text{ lb (WD)}$$

Correct FBD's

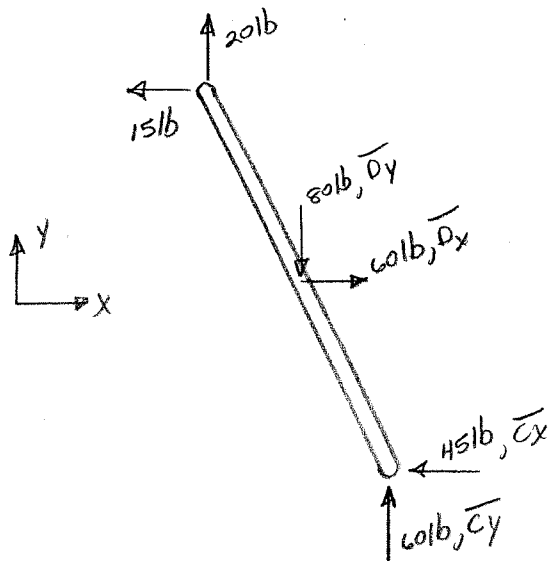
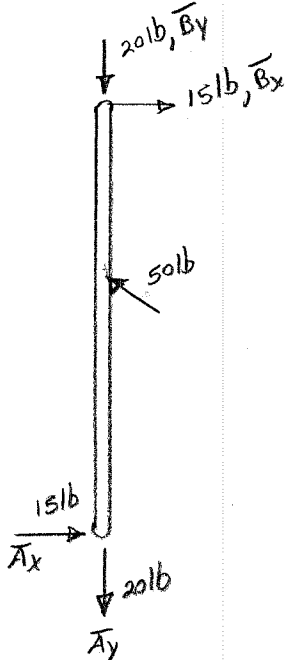

12B. For the position shown, the ground is applying a 20 kN horizontal force on the tip of the bucket.

- a. Determine the forces acting at pins B and E due to the arm BAO and the hydraulic cylinder ED.

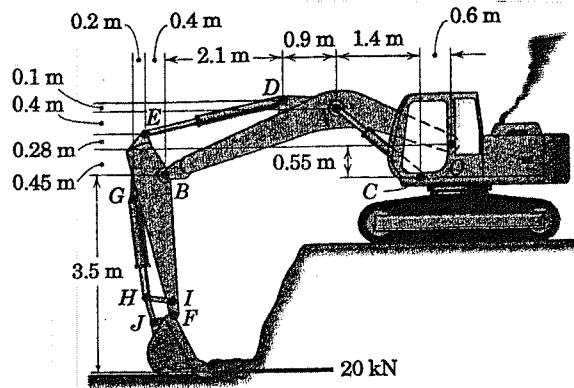

since, I am only interested in the forces at E and B, I am going to "section" the machine at E and D.  
 note: ED is a 2FM

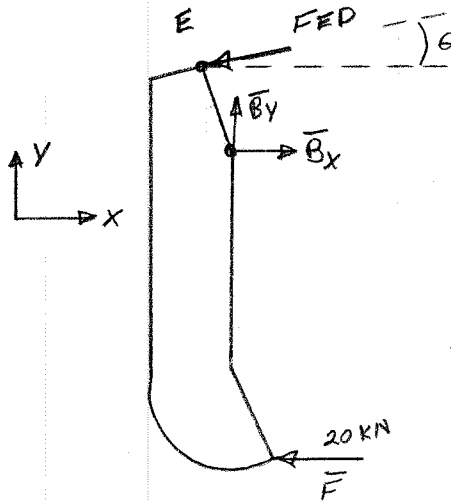

$$\tan \theta = \frac{(.4 + .1)}{(2.1 + .4)} = \frac{.5}{2.5}$$

$$\theta = 11.3^\circ$$

$$\sum \bar{F}_x = (-F_{ED} \cos 11.3^\circ + B_x - 20 \text{ kN}) \bar{i}$$

$$\sum \bar{F}_y = (-F_{ED} \sin 11.3^\circ + B_y) \bar{j}$$

$$\sum \bar{M}_B = 0 = (-20(3.5) + F_{ED} \cos 11.3^\circ (.45 + .28) + F_{ED} \sin 11.3^\circ (.4)) \bar{k}$$

$$= -70 \text{ kNm} + .716 F_{ED} + .0784 F_{ED} = 0$$

$$\therefore F_{ED} = 88.1 \text{ kN}$$

$$\therefore B_x = 106 \text{ kN}$$

$$B_y = 17.3 \text{ kN}$$