

SOLUTION (10.22)

Known: The cylinder head of a piston-type air compressor is held in place by ten bolts. Total joint stiffness is four times total bolt stiffness. Each bolt is tightened to an initial tension of 5000 N. The total external force acting to separate the joint fluctuates between 10,000 and 20,000 N.

Find: Draw a graph (plotting force vs. time) showing three or four external load fluctuations, and draw corresponding curves showing the fluctuations in total bolt load and total joint clamping force.

Schematic and Given Data:

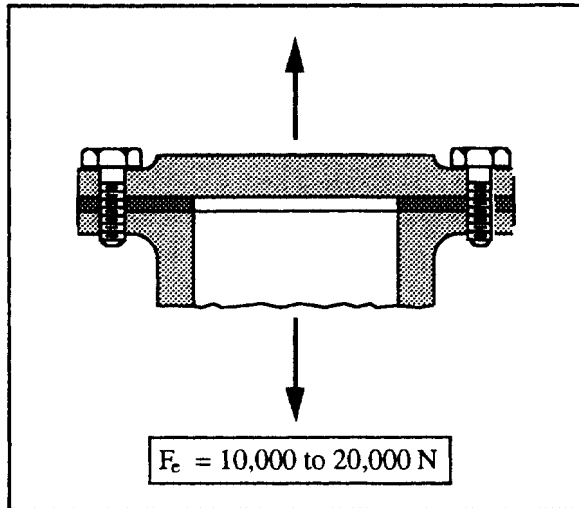

Assumption: The bolt size and material are such that the bolt load remains within the elastic range.

Analysis:

1. Using Eq. (10.13) for $F_e = 20,000 \text{ N}$,

$$\begin{aligned} F_b &= F_i + \left(\frac{k_b}{k_b + k_c} \right) F_e = [(5000)(10)] + \frac{1}{1 + 4} (20,000) \\ &= 54,000 \text{ N} \end{aligned}$$

$$\begin{aligned} F_c &= F_i - \left(\frac{k_c}{k_c + k_b} \right) F_e = 50,000 - \frac{4}{5} (20,000) \\ &= 34,000 \text{ N} \end{aligned}$$

2. For $F_e = 10,000 \text{ N}$,

$$F_b = 50,000 + \frac{1}{1 + 4} (10,000) = 52,000 \text{ N}$$

$$F_c = 50,000 - \frac{4}{5} (10,000) = 42,000 \text{ N}$$

3.

