

Chapter 2

Moments, Couples, Forces, Equivalent Systems

2.1 Position Vector

The position vector of a point P relative to a point O is a vector $\mathbf{r}_{OP} = \overrightarrow{OP}$ having the following characteristics:

- magnitude the length of line OP ;
- orientation parallel to line OP ;
- sense OP (from point O to point P).

The vector \mathbf{r}_{OP} is shown as an arrow connecting O to P , as depicted in Fig. 2.1(a). The position of a point P relative to P is a zero vector.

Let $\mathbf{i}, \mathbf{j}, \mathbf{k}$ be mutually perpendicular unit vectors (cartesian reference frame) with the origin at O , as shown in Fig. 2.1(b). The axes of the cartesian reference frame are x, y, z . The unit vectors $\mathbf{i}, \mathbf{j}, \mathbf{k}$ are parallel to x, y, z , and they have the senses of the positive x, y, z axes. The coordinates of the origin O are $x = y = z = 0$, i.e., $O(0, 0, 0)$. The coordinates of a point P are $x = x_P, y = y_P, z = z_P$, i.e., $P(x_P, y_P, z_P)$. The position vector of P relative to the origin O is

$$\mathbf{r}_{OP} = \mathbf{r}_P = \overrightarrow{OP} = x_P \mathbf{i} + y_P \mathbf{j} + z_P \mathbf{k}.$$

The position vector of the point P relative to a point $M, M \neq O$ of coordinates (x_M, y_M, z_M) is

$$\mathbf{r}_{MP} = \overrightarrow{MP} = (x_P - x_M) \mathbf{i} + (y_P - y_M) \mathbf{j} + (z_P - z_M) \mathbf{k}.$$

The distance d between P and M is given by

$$d = |\mathbf{r}_P - \mathbf{r}_M| = |\mathbf{r}_{MP}| = |\overrightarrow{MP}| = \sqrt{(x_P - x_M)^2 + (y_P - y_M)^2 + (z_P - z_M)^2}.$$

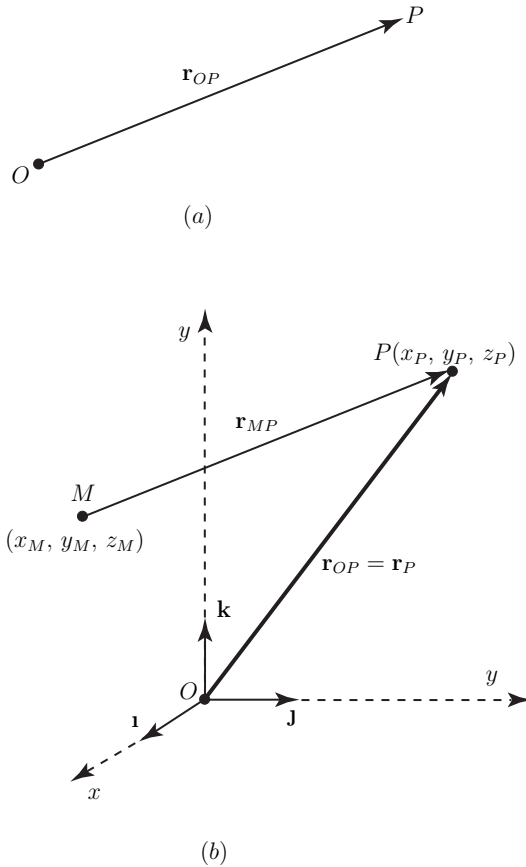

Fig. 2.1 Position vector

2.2 Moment of a Bound Vector About a Point

Definition. The moment of a bound vector \mathbf{v} about a point A is the vector

$$\mathbf{M}_A^{\mathbf{v}} = \mathbf{r}_{AB} \times \mathbf{v}, \quad (2.1)$$

where \mathbf{r}_{AB} is the position vector of B relative to A , and B is any point of line of action, Δ , of the vector \mathbf{v} (Fig. 2.2).

The vector $\mathbf{M}_A^{\mathbf{v}} = \mathbf{0}$ if and only the line of action of \mathbf{v} passes through A or $\mathbf{v} = \mathbf{0}$. The magnitude of $\mathbf{M}_A^{\mathbf{v}}$ is

$$|\mathbf{M}_A^{\mathbf{v}}| = M_A^{\mathbf{v}} = |\mathbf{r}_{AB}| |\mathbf{v}| \sin \theta,$$

where θ is the angle between \mathbf{r}_{AB} and \mathbf{v} when they are placed tail to tail. The perpendicular distance from A to the line of action of \mathbf{v} is

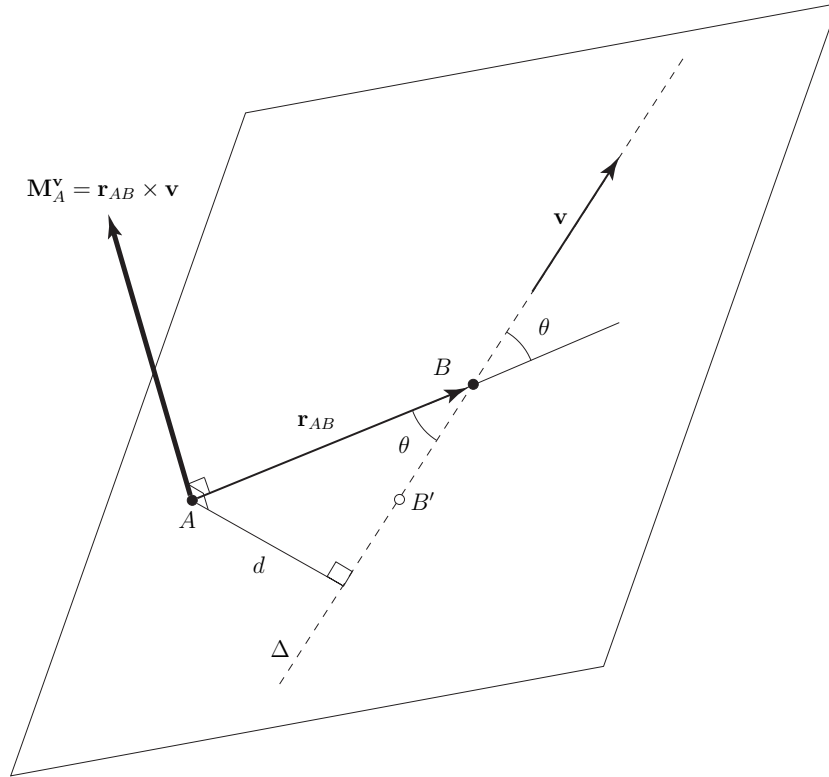

Fig. 2.2 Moment of a bound vector \mathbf{v} about a point A

$$d = |\mathbf{r}_{AB}| \sin \theta,$$

and the magnitude of $\mathbf{M}_A^{\mathbf{v}}$ is

$$|\mathbf{M}_A^{\mathbf{v}}| = M_A^{\mathbf{v}} = d |\mathbf{v}|.$$

The vector $\mathbf{M}_A^{\mathbf{v}}$ is perpendicular to both \mathbf{r}_{AB} and \mathbf{v} : $\mathbf{M}_A^{\mathbf{v}} \perp \mathbf{r}_{AB}$ and $\mathbf{M}_A^{\mathbf{v}} \perp \mathbf{v}$. The vector $\mathbf{M}_A^{\mathbf{v}}$ being perpendicular to \mathbf{r}_{AB} and \mathbf{v} is perpendicular to the plane containing \mathbf{r}_{AB} and \mathbf{v} .

The moment given by Eq. (2.1) does not depend on the point B of the line of action of \mathbf{v} , Δ , where \mathbf{r}_{AB} intersects Δ . Instead of using the point B the point B' (Fig. 2.2) can be used. The position vector of B relative to A is $\mathbf{r}_{AB} = \mathbf{r}_{AB'} + \mathbf{r}_{B'B}$ where the vector $\mathbf{r}_{B'B}$ is parallel to \mathbf{v} , $\mathbf{r}_{B'B} \parallel \mathbf{v}$. Therefore,

$$\mathbf{M}_A^{\mathbf{v}} = \mathbf{r}_{AB} \times \mathbf{v} = (\mathbf{r}_{AB'} + \mathbf{r}_{B'B}) \times \mathbf{v} = \mathbf{r}_{AB'} \times \mathbf{v} + \mathbf{r}_{B'B} \times \mathbf{v} = \mathbf{r}_{AB'} \times \mathbf{v},$$

because $\mathbf{r}_{B'B} \times \mathbf{v} = \mathbf{0}$.

Moment of a Bound Vector About a Line

Definition. The moment $\mathbf{M}_\Omega^{\mathbf{v}}$ of a bound vector \mathbf{v} about a line Ω is the Ω resolute (Ω component) of the moment \mathbf{v} about any point on Ω Fig. 2.3.

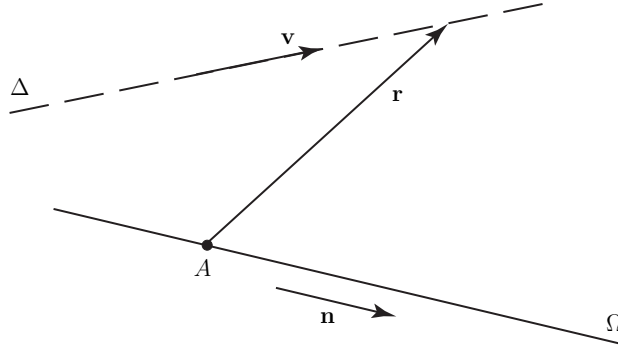

Fig. 2.3 Moment of a bound vector \mathbf{v} about a line Ω

The $\mathbf{M}_\Omega^{\mathbf{v}}$ is the Ω resolute of $\mathbf{M}_A^{\mathbf{v}}$

$$\begin{aligned}\mathbf{M}_\Omega^{\mathbf{v}} &= \mathbf{n} \cdot \mathbf{M}_A^{\mathbf{v}} \mathbf{n} \\ &= \mathbf{n} \cdot (\mathbf{r} \times \mathbf{v}) \mathbf{n} \\ &= [\mathbf{n}, \mathbf{r}, \mathbf{v}] \mathbf{n},\end{aligned}$$

where \mathbf{n} is a unit vector parallel to Ω , and \mathbf{r} is the position vector of a point on the line of action of \mathbf{v} relative to a point on Ω .

The magnitude of $\mathbf{M}_\Omega^{\mathbf{v}}$ is given by

$$|\mathbf{M}_\Omega^{\mathbf{v}}| = |[\mathbf{n}, \mathbf{r}, \mathbf{v}]|.$$

The moment of a vector about a line is a free vector.

If a line Ω is parallel to the line of action Δ of a vector \mathbf{v} , then $[\mathbf{n}, \mathbf{r}, \mathbf{v}] \mathbf{n} = \mathbf{0}$ and $\mathbf{M}_\Omega^{\mathbf{v}} = \mathbf{0}$.

If a line Ω intersects the line of action Δ of \mathbf{v} , then \mathbf{r} can be chosen in such a way that $\mathbf{r} = \mathbf{0}$ and $\mathbf{M}_\Omega^{\mathbf{v}} = \mathbf{0}$.

If a line Ω is perpendicular to the line of action Δ of a vector \mathbf{v} , and d is the shortest distance between these two lines, then

$$|\mathbf{M}_\Omega^{\mathbf{v}}| = d|\mathbf{v}|.$$

Moments of a System of Bound Vectors

Definition. The moment of a system $\{S\}$ of bound vectors \mathbf{v}_i , $\{S\} = \{\mathbf{v}_1, \mathbf{v}_2, \dots, \mathbf{v}_n\} = \{\mathbf{v}_i\}_{i=1,2,\dots,n}$ about a point A is

$$\mathbf{M}_A^{\{S\}} = \sum_{i=1}^n \mathbf{M}_A^{\mathbf{v}_i}.$$

Definition. The moment of a system $\{S\}$ of bound vectors \mathbf{v}_i , $\{S\} = \{\mathbf{v}_1, \mathbf{v}_2, \dots, \mathbf{v}_n\} = \{\mathbf{v}_i\}_{i=1,2,\dots,n}$ about a line Ω is

$$\mathbf{M}_\Omega^{\{S\}} = \sum_{i=1}^n \mathbf{M}_\Omega^{\mathbf{v}_i}.$$

The moments $\mathbf{M}_A^{\{S\}}$ and $\mathbf{M}_P^{\{S\}}$ of a system $\{S\}$, $\{S\} = \{\mathbf{v}_i\}_{i=1,2,\dots,n}$, of bound vectors, \mathbf{v}_i , about two points A and P , are related to each other as follows,

$$\mathbf{M}_A^{\{S\}} = \mathbf{M}_P^{\{S\}} + \mathbf{r}_{AP} \times \mathbf{R}, \quad (2.2)$$

where \mathbf{r}_{AP} is the position vector of P relative to A , and \mathbf{R} is the resultant of $\{S\}$.

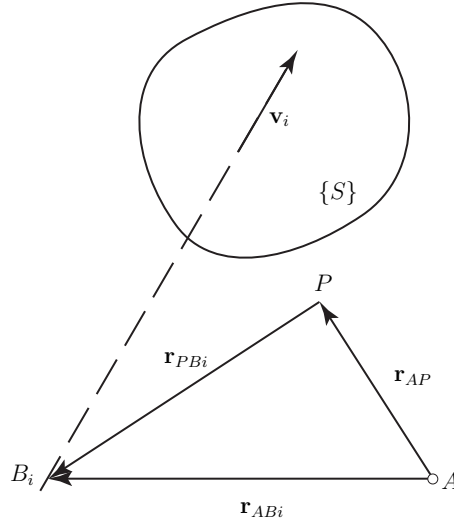

Fig. 2.4 Moments of a system of bound vectors, \mathbf{v}_i about two points A and P

Proof. Let B_i a point on the line of action of the vector \mathbf{v}_i , \mathbf{r}_{AB_i} and \mathbf{r}_{PB_i} the position vectors of B_i relative to A and P , Fig. 2.4. Thus,

$$\begin{aligned} \mathbf{M}_A^{\{S\}} &= \sum_{i=1}^n \mathbf{M}_A^{\mathbf{v}_i} = \sum_{i=1}^n \mathbf{r}_{AB_i} \times \mathbf{v}_i \\ &= \sum_{i=1}^n (\mathbf{r}_{AP} + \mathbf{r}_{PB_i}) \times \mathbf{v}_i = \sum_{i=1}^n (\mathbf{r}_{AP} \times \mathbf{v}_i + \mathbf{r}_{PB_i} \times \mathbf{v}_i) \end{aligned}$$

$$\begin{aligned}
&= \sum_{i=1}^n \mathbf{r}_{AP} \times \mathbf{v}_i + \sum_{i=1}^n \mathbf{r}_{PB_i} \times \mathbf{v}_i \\
&= \mathbf{r}_{AP} \times \sum_{i=1}^n \mathbf{v}_i + \sum_{i=1}^n \mathbf{r}_{PB_i} \times \mathbf{v}_i \\
&= \mathbf{r}_{AP} \times \mathbf{R} + \sum_{i=1}^n \mathbf{M}_P^{v_i} \\
&= \mathbf{r}_{AP} \times \mathbf{R} + \mathbf{M}_P^{\{S\}}.
\end{aligned}$$

If the resultant \mathbf{R} of a system $\{S\}$ of bound vectors is not equal to zero, $\mathbf{R} \neq \mathbf{0}$, the points about which $\{S\}$ has a minimum moment \mathbf{M}_{min} lie on a line called *central axis*, (CA), of $\{S\}$, which is parallel to \mathbf{R} and passes through a point P whose position vector \mathbf{r} relative to an arbitrarily selected reference point O is given by

$$\mathbf{r} = \frac{\mathbf{R} \times \mathbf{M}_O^{\{S\}}}{\mathbf{R}^2}.$$

The minimum moment \mathbf{M}_{min} is given by

$$\mathbf{M}_{min} = \frac{\mathbf{R} \cdot \mathbf{M}_O^{\{S\}}}{\mathbf{R}^2} \mathbf{R}.$$

2.3 Couples

Definition. A *couple* is a system of bound vectors whose resultant is equal to zero and whose moment about some point is not equal to zero.

A system of vectors is not a vector, therefore couples are not vectors.

A couple consisting of only two vectors is called a *simple couple*. The vectors of a simple couple have equal magnitudes, parallel lines of action, and opposite senses.

Writers use the word “couple” to denote the simple couple.

The moment of a couple about a point is called the *torque* of the couple, \mathbf{M} or \mathbf{T} . The moment of a couple about one point is equal to the moment of the couple about any other point, i.e., it is unnecessary to refer to a specific point. The moment of a couple is a free vector.

The torques are vectors and the magnitude of a torque of a simple couple is given by

$$|\mathbf{M}| = d|\mathbf{v}|,$$

where d is the distance between the lines of action of the two vectors comprising the couple, and \mathbf{v} is one of these vectors.

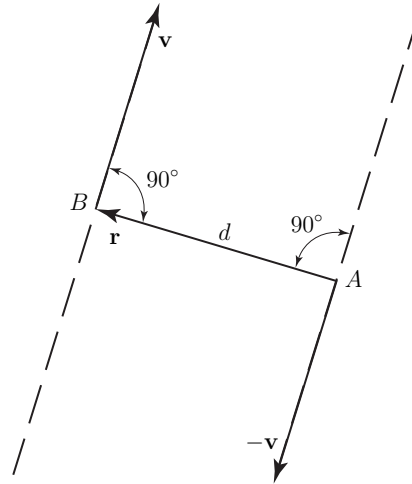

Fig. 2.5 Couple of the vectors \mathbf{v} and $-\mathbf{v}$, simple couple

Proof. In Fig. 2.5, the torque \mathbf{M} is the sum of the moments of \mathbf{v} and $-\mathbf{v}$ about any point. The moments about point A are

$$\mathbf{M} = \mathbf{M}_A^{\mathbf{v}} + \mathbf{M}_A^{-\mathbf{v}} = \mathbf{r} \times \mathbf{v} + \mathbf{0}.$$

Hence,

$$|\mathbf{M}| = |\mathbf{r} \times \mathbf{v}| = |\mathbf{r}||\mathbf{v}|\sin(\mathbf{r}, \mathbf{v}) = d|\mathbf{v}|.$$

The direction of the torque of a simple couple can be determined by inspection: \mathbf{M} is perpendicular to the plane determined by the lines of action of the two vectors comprising the couple, and the sense of \mathbf{M} is the same as that of $\mathbf{r} \times \mathbf{v}$.

The moment of a couple about a line Ω is equal to the Ω resolute of the torque of the couple.

The moments of a couple about two parallel lines are equal to each other.

2.4 Equivalence of Systems

Definition. Two systems $\{S\}$ and $\{S'\}$ of bound vectors are said to be *equivalent* when:

1. the resultant of $\{S\}$, \mathbf{R} , is equal to the resultant of $\{S'\}$, \mathbf{R}'

$$\mathbf{R} = \mathbf{R}'$$

2. there exists at least one point about which $\{S\}$ and $\{S'\}$ have equal moments

$$\text{exists } P: \mathbf{M}_P^{\{S\}} = \mathbf{M}_P^{\{S'\}}.$$

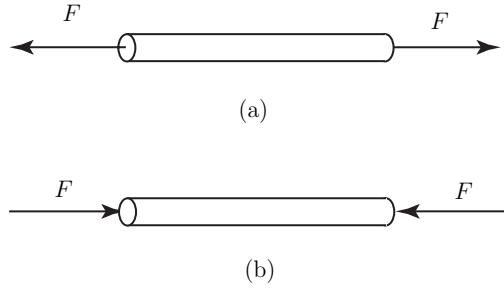

Fig. 2.6 Rod subjected to the action of a pair of forces

Figures 2.6(a) and 2.6(b) each show a rod subjected to the action of a pair of forces. The two pairs of forces are equivalent, but their effects on the rod are different from each other. The word “equivalence” is not to be regarded as implying physical equivalence.

For given a line Ω and two equivalent systems $\{S\}$ and $\{S'\}$ of bound vectors, the sum of the Ω resolutes of the vectors in $\{S\}$ is equal to the sum of the Ω resolutes of the vectors in $\{S'\}$.

The moments of two equivalent systems of bound vectors, about point, are equal to each other.

The moments of two equivalent systems $\{S\}$ and $\{S'\}$ of bound vectors, about any line Ω , are equal to each other.

Transitivity of the equivalence relation. If $\{S\}$ is equivalent to $\{S'\}$, and $\{S'\}$ is equivalent to $\{S''\}$, then $\{S\}$ is equivalent to $\{S''\}$.

Every system $\{S\}$ of bound vectors with the resultant \mathbf{R} can be replaced with a system consisting of a couple C and a single bound vector \mathbf{v} whose line of action passes through an arbitrarily selected *base point* O . The torque \mathbf{M} of C depends on the choice of base point $\mathbf{M} = \mathbf{M}_O^{\{S\}}$. The vector \mathbf{v} is independent of the choice of base point, $\mathbf{v} = \mathbf{R}$.

A couple C can be replaced with any system of couples, the sum of whose torque is equal to the torque of C .

When a system of bound vectors consists of a couple of torque \mathbf{M} and a single vector parallel to \mathbf{M} , it is called a *wrench*.

2.5 Force Vector and Moment of a Force

Force is a vector quantity, having both magnitude and direction. Force is commonly explained in terms of Newton's three laws of motion set forth in his *Principia Mathematica* (1687). Newton's first principle: a body that is at rest or moving at a uniform rate in a straight line will remain in that state until some force is applied to it. Newton's second law of motion states that a particle acted on by forces whose resultant is not zero will move in such a way that the time rate of change of its momentum will at any instant be proportional to the resultant force. Newton's third law states that when one body exerts a force on another body, the second body exerts an equal force on the first body. This is the principle of action and reaction.

Because force is a vector quantity it can be represented graphically as a directed line segment. The representation of forces by vectors implies that they are concentrated either at a single point or along a single line. The force of gravity is invariably distributed throughout the volume of a body. Nonetheless, when the equilibrium of a body is the primary consideration, it is generally valid as well as convenient to assume that the forces are concentrated at a single point. In the case of gravitational force, the total weight of a body may be assumed to be concentrated at its center of gravity.

Force is measured in newtons (N); a force of 1 N will accelerate a mass of one kilogram at a rate of one meter per second. The newton is a unit of the International System (SI) used for measuring force.

Using the English system, the force is measured in pounds. One pound of force imparts to a one-pound object an acceleration of 32.17 feet per second squared.

The force vector \mathbf{F} can be expressed in terms of a cartesian reference frame, with the unit vectors \mathbf{i} , \mathbf{j} , and \mathbf{k} , Fig. 2.7(a)

$$\mathbf{F} = F_x\mathbf{i} + F_y\mathbf{j} + F_z\mathbf{k}. \quad (2.3)$$

The components of the force in the x , y , and z directions are F_x , F_y , and F_z . The resultant of two forces: $\mathbf{F}_1 = F_{1x}\mathbf{i} + F_{1y}\mathbf{j} + F_{1z}\mathbf{k}$ and $\mathbf{F}_2 = F_{2x}\mathbf{i} + F_{2y}\mathbf{j} + F_{2z}\mathbf{k}$ is the vector sum of those forces

$$\mathbf{R} = \mathbf{F}_1 + \mathbf{F}_2 = (F_{1x} + F_{2x})\mathbf{i} + (F_{1y} + F_{2y})\mathbf{j} + (F_{1z} + F_{2z})\mathbf{k}. \quad (2.4)$$

A moment is defined as the moment of a force about (with respect to) a point. The moment of the force \mathbf{F} about the point O is the cross product vector

$$\begin{aligned} \mathbf{M}_O^{\mathbf{F}} &= \mathbf{r} \times \mathbf{F} \\ &= \begin{vmatrix} \mathbf{i} & \mathbf{j} & \mathbf{k} \\ r_x & r_y & r_z \\ F_x & F_y & F_z \end{vmatrix} \\ &= (r_y F_z - r_z F_y)\mathbf{i} + (r_z F_x - r_x F_z)\mathbf{j} + (r_x F_y - r_y F_x)\mathbf{k}. \end{aligned} \quad (2.5)$$

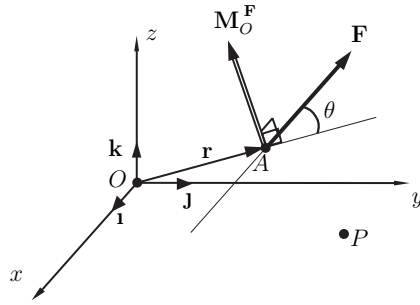

(a)

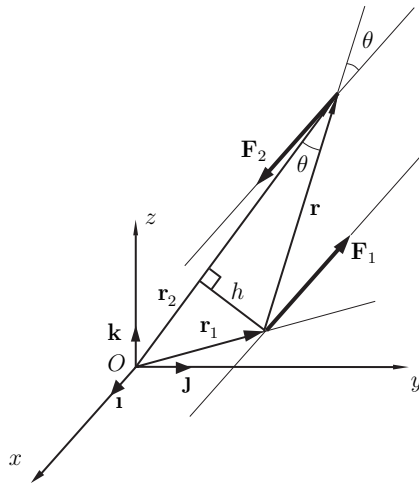

(b)

Fig. 2.7 (a) Moment of a force about (with respect to) a point and (b) couple of two forces

where $\mathbf{r} = r_x\mathbf{i} + r_y\mathbf{j} + r_z\mathbf{k}$ is a position vector directed from the point about which the moment is taken (O in this case) to any point A on the line of action of the force, see Fig. 2.7(a). If the coordinates of O are x_O, y_O, z_O and the coordinates of A are x_A, y_A, z_A , then $\mathbf{r} = \mathbf{r}_{OA} = (x_A - x_O)\mathbf{i} + (y_A - y_O)\mathbf{j} + (z_A - z_O)\mathbf{k}$ and the the moment of the force \mathbf{F} about the point O is

$$\mathbf{M}_O^{\mathbf{F}} = \mathbf{r}_{OA} \times \mathbf{F} = \begin{vmatrix} \mathbf{i} & \mathbf{j} & \mathbf{k} \\ x_A - x_O & y_A - y_O & z_A - z_O \\ F_x & F_y & F_z \end{vmatrix}.$$

The magnitude of $\mathbf{M}_O^{\mathbf{F}}$ is

$$|\mathbf{M}_O^{\mathbf{F}}| = M_O^{\mathbf{F}} = rF |\sin \theta|,$$

where $\theta = \angle(\mathbf{r}, \mathbf{F})$ is the angle between vectors \mathbf{r} and \mathbf{F} , and $r = |\mathbf{r}|$ and $F = |\mathbf{F}|$ are the magnitudes of the vectors.

The line of action of $\mathbf{M}_O^{\mathbf{F}}$ is perpendicular to the plane containing \mathbf{r} and \mathbf{F} ($\mathbf{M}_O^{\mathbf{F}} \perp \mathbf{r}$ & $\mathbf{M}_O^{\mathbf{F}} \perp \mathbf{F}$) and the sense is given by the right-hand rule.

The moment of the force \mathbf{F} about another point P is

$$\mathbf{M}_P^{\mathbf{F}} = \mathbf{r}_{PA} \times \mathbf{F} = \begin{vmatrix} \mathbf{i} & \mathbf{j} & \mathbf{k} \\ x_A - x_P & y_A - y_P & z_A - z_P \\ F_x & F_y & F_z \end{vmatrix},$$

where x_P, y_P, z_P are the coordinates of the point P .

The system of two forces, \mathbf{F}_1 and \mathbf{F}_2 , which have equal magnitudes $|\mathbf{F}_1| = |\mathbf{F}_2|$, opposite senses $\mathbf{F}_1 = -\mathbf{F}_2$, and parallel directions ($\mathbf{F}_1 \parallel \mathbf{F}_2$) is a couple. The resultant force of a couple is zero $\mathbf{R} = \mathbf{F}_1 + \mathbf{F}_2 = \mathbf{0}$. The resultant moment $\mathbf{M} \neq \mathbf{0}$ about an arbitrary point is

$$\mathbf{M} = \mathbf{r}_1 \times \mathbf{F}_1 + \mathbf{r}_2 \times \mathbf{F}_2,$$

or

$$\mathbf{M} = \mathbf{r}_1 \times (-\mathbf{F}_2) + \mathbf{r}_2 \times \mathbf{F}_2 = (\mathbf{r}_2 - \mathbf{r}_1) \times \mathbf{F}_2 = \mathbf{r} \times \mathbf{F}_2, \quad (2.6)$$

where $\mathbf{r} = \mathbf{r}_2 - \mathbf{r}_1$ is a vector from any point on the line of action of \mathbf{F}_1 to any point on the line of action of \mathbf{F}_2 . The direction of the torque of the couple is perpendicular to the plane of the couple and the magnitude is given by, Fig. 2.7(b)

$$|\mathbf{M}| = M = rF_2 |\sin \theta| = hF_2, \quad (2.7)$$

where $h = r|\sin \theta|$ is the perpendicular distance between the lines of action. The resultant moment of a couple is independent of the point with respect to which moments are taken.

2.6 Representing Systems by Equivalent Systems

To simplify the analysis of the forces and moments acting on a given system one can represent the system by an equivalent a less complicated one. The actual forces and moments can be replaced with a total force and a total moment.

Figure 2.8 shows an arbitrary system of forces and moments, {system I}, and a point I . This system can be represented by a system, {system II}, consisting of a single force \mathbf{F} acting at P and a single couple of torque \mathbf{M} . The conditions for equivalence are

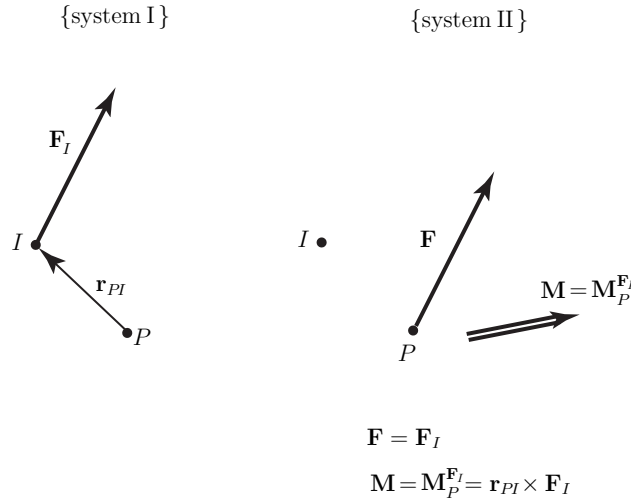

Fig. 2.8 Equivalent systems

$$\sum \mathbf{F}^{\{\text{system II}\}} = \sum \mathbf{F}^{\{\text{system I}\}} \implies \mathbf{F} = \sum \mathbf{F}^{\{\text{system I}\}},$$

and

$$\sum \mathbf{M}_P^{\{\text{system II}\}} = \sum \mathbf{M}_P^{\{\text{system I}\}} \implies \mathbf{M} = \sum \mathbf{M}_P^{\{\text{system I}\}}.$$

These conditions are satisfied if \mathbf{F} equals the sum of the forces in $\{\text{system I}\}$, and \mathbf{M} equals the sum of the moments about P in $\{\text{system I}\}$. Thus, no matter how complicated a system of forces and moments may be, it can be represented by a single force acting at a given point and a single couple. Three particular cases occur frequently in practice.

1. *Force represented by a force and a couple.*

A force \mathbf{F}_I acting at a point I $\{\text{system I}\}$ in Fig. 2.8 can be represented by a force \mathbf{F} acting at a different point P and a couple of torque \mathbf{M} , $\{\text{system II}\}$. The moment of $\{\text{system I}\}$ about point P is $\mathbf{r}_{PI} \times \mathbf{F}_I$, where \mathbf{r}_{PI} is the vector from P to I . The conditions for equivalence are

$$\sum \mathbf{F}^{\{\text{system II}\}} = \sum \mathbf{F}^{\{\text{system I}\}} \implies \mathbf{F} = \mathbf{F}_I,$$

and

$$\sum \mathbf{M}_P^{\{\text{system II}\}} = \sum \mathbf{M}_P^{\{\text{system I}\}} \implies \mathbf{M} = \mathbf{M}_P^{\mathbf{F}_I} = \mathbf{r}_{PI} \times \mathbf{F}_I.$$

The systems are equivalent if the force \mathbf{F} equals the force \mathbf{F}_I and the couple of torque $\mathbf{M}_P^{\mathbf{F}_I}$ equals the moment of \mathbf{F}_I about P .

2. Concurrent forces represented by a force.

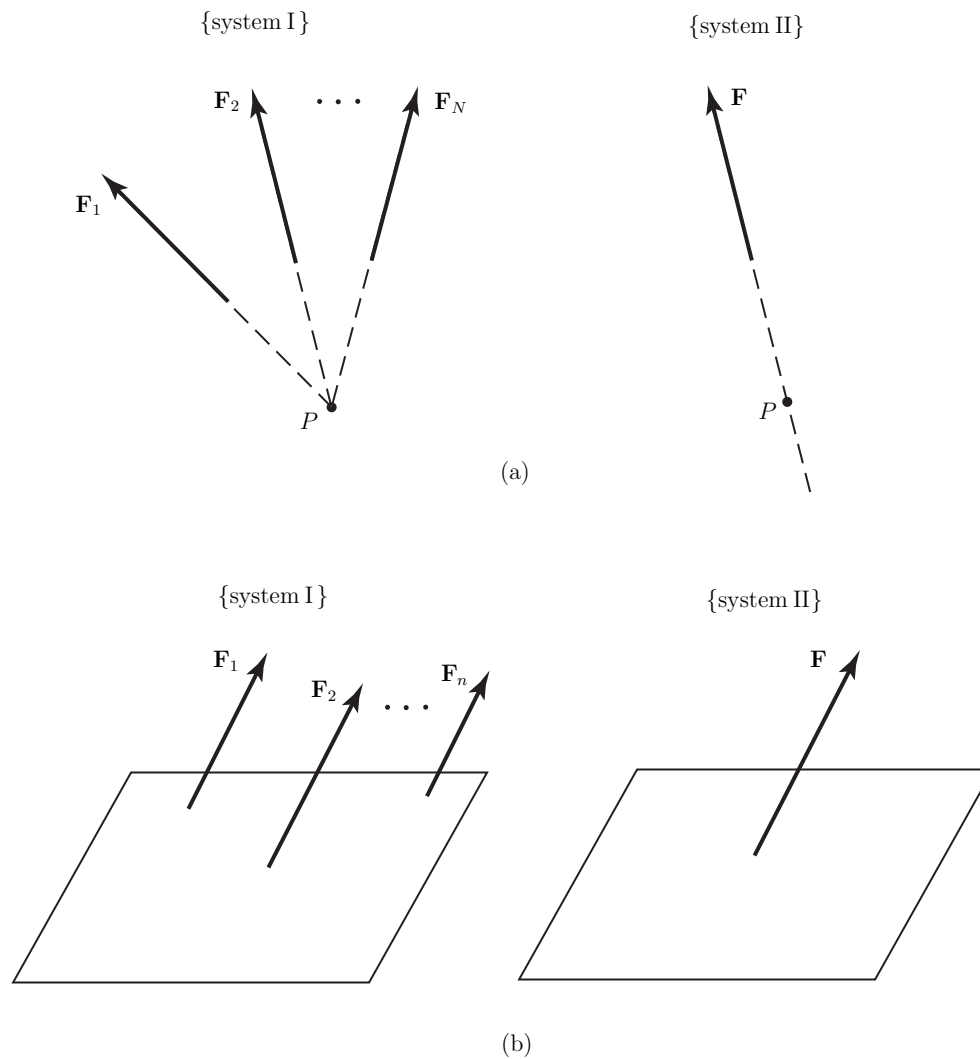

Fig. 2.9 (a) System of concurrent forces and (b) system of parallel forces

A system of concurrent forces whose lines of action intersect at a point P {system I} in Fig. 2.9(a), can be represented by a single force whose line of action intersects P , {system II}. The sums of the forces in the two systems are equal if

$$\mathbf{F} = \mathbf{F}_1 + \mathbf{F}_2 + \dots + \mathbf{F}_n.$$

The sum of the moments about P equals zero for each system, so the systems are equivalent if the force \mathbf{F} equals the sum of the forces in {system I}.

3. *Parallel forces represented by a force.*

A system of parallel forces whose sum is not zero can be represented by a single force \mathbf{F} shown in Fig. 2.9(b).

4. *System represented by a wrench.*

In general any system of forces and moments can be represented by a single force acting at a given point and a single couple.

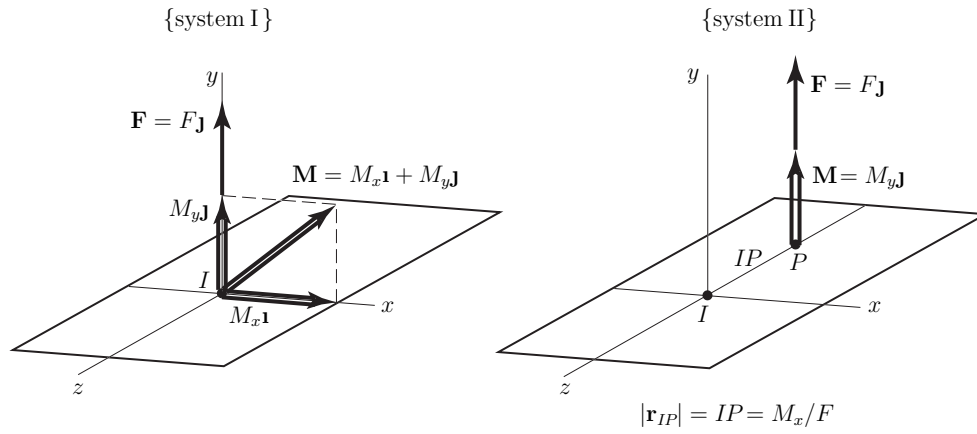

Fig. 2.10 System represented by a wrench

Figure 2.10 shows an arbitrary force \mathbf{F} acting at a point I and an arbitrary couple of torque \mathbf{M} , {system I}. This system can be represented by a simpler one, i.e., one may represent the force \mathbf{F} acting at a different point P and the component of \mathbf{M} that is parallel to \mathbf{F} . A coordinate system is chosen so that \mathbf{F} is along the y axis

$$\mathbf{F} = F\mathbf{j},$$

and \mathbf{M} is contained in the xy plane

$$\mathbf{M} = M_x\mathbf{i} + M_y\mathbf{j}.$$

The equivalent system, {system II}, consists of the force \mathbf{F} acting at a point P on the z axis

$$\mathbf{F} = F\mathbf{j},$$

and the component of \mathbf{M} parallel to \mathbf{F}

$$\mathbf{M}_p = M_y\mathbf{j}.$$

The distance IP is chosen so that $|\mathbf{r}_{IP}| = IP = M_x/F$. The {system I} is equivalent to {system II}.

The sum of the forces in each system is the same \mathbf{F} .

The sum of the moments about I in {system I} is \mathbf{M} , and the sum of the moments about I in {system II} is

$$\sum \mathbf{M}_I^{\{\text{system II}\}} = \mathbf{r}_{PI} \times \mathbf{F} + M_y \mathbf{j} = [-(IP) \mathbf{k}] \times (F \mathbf{j}) + M_y \mathbf{j} = M_x \mathbf{i} + M_y \mathbf{j} = \mathbf{M}.$$

The system of the force $\mathbf{F} = F \mathbf{j}$ and the couple $\mathbf{M}_p = M_y \mathbf{j}$ that is parallel to \mathbf{F} is a wrench. A wrench is the simplest system that can be equivalent to an arbitrary system of forces and moments.

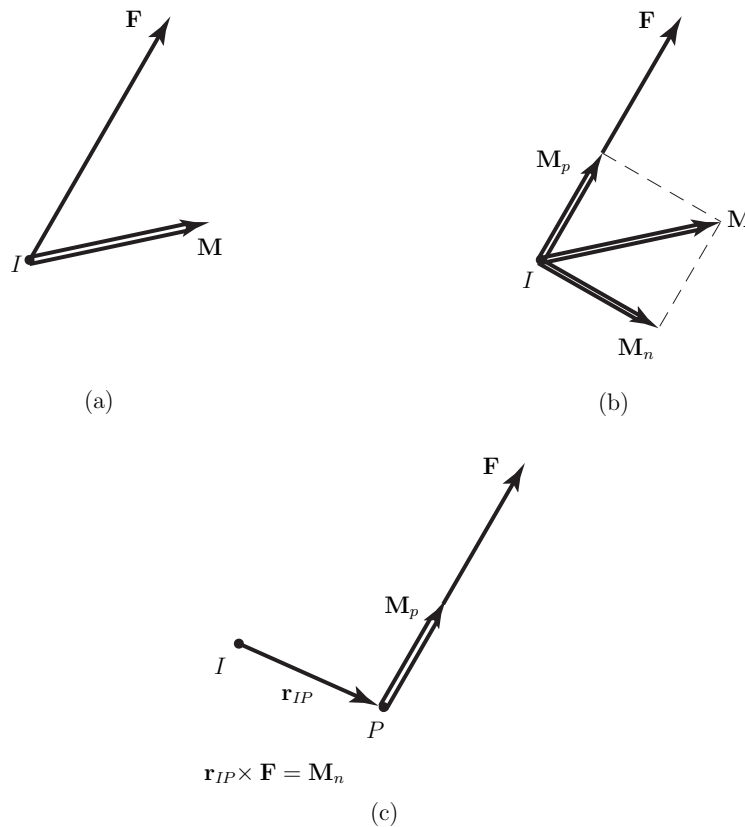

Fig. 2.11 Steps required to represent a system of forces and moments by a wrench

The representation of a given system of forces and moments by a wrench requires the following steps:

1. Choose a convenient point I and represent the system by a force \mathbf{F} acting at P and a couple \mathbf{M} , see Fig. 2.11(a).

2. Determine the components of \mathbf{M} parallel and normal to \mathbf{F} , see Fig. 2.11(b):

$$\mathbf{M} = \mathbf{M}_p + \mathbf{M}_n, \text{ where } \mathbf{M}_p \parallel \mathbf{F}.$$

3. The wrench consists of the force \mathbf{F} acting at a point P and the parallel component \mathbf{M}_p , see Fig. 2.11(c). For equivalence, the following condition must be satisfied:

$$\mathbf{r}_{IP} \times \mathbf{F} = \mathbf{M}_n,$$

where \mathbf{M}_n is the normal component of \mathbf{M} .

In general, the {system I} cannot be represented by a force \mathbf{F} alone.

2.7 Problems

- 2.1 Determine the resultant of the forces $\mathbf{F}_1 = F_{1x}\mathbf{i} + F_{1y}\mathbf{j} + F_{1z}\mathbf{k}$, $\mathbf{F}_2 = F_{2x}\mathbf{i} + F_{2y}\mathbf{j} + F_{2z}\mathbf{k}$, and $\mathbf{F}_3 = F_{3x}\mathbf{i} + F_{3y}\mathbf{j} + F_{3z}\mathbf{k}$, which are concurrent at the point $P = P(x, y, z)$, where $F_{1x} = 2$, $F_{1y} = 3.5$, $F_{1z} = -3$, $F_{2x} = -1.5$, $F_{2y} = 4.5$, $F_{2z} = -3$, $F_{3x} = 7$, $F_{3y} = -6$, $F_{3z} = 5$, and $P = P(2, 3, -4)$. The units for the forces are in Newtons and for the coordinates are given in meters.
- 2.2 Determine the resultant of the three forces shown in Fig. 2.12. The force \mathbf{F}_1 acts along the x -axis, the force \mathbf{F}_2 acts along the z -axis, and the direction of the force \mathbf{F}_3 is given by the line O_3P_3 , where $O_3 = O(x_{O_3}, y_{O_3}, z_{O_3})$ and $P_3 = P(x_{P_3}, y_{P_3}, z_{P_3})$. The application point of the forces \mathbf{F}_1 and \mathbf{F}_2 is the origin O of the reference frame as shown in Fig. 2.12.
 Numerical application: $|\mathbf{F}_1| = F_1 = 250$ N, $|\mathbf{F}_2| = F_2 = 300$ N, $|\mathbf{F}_3| = F_3 = 300$ N, $O_3 = O_3(7, 5, 0)$ and $P_3 = P_3(10, 5, -6)$. The coordinates are given in meters.

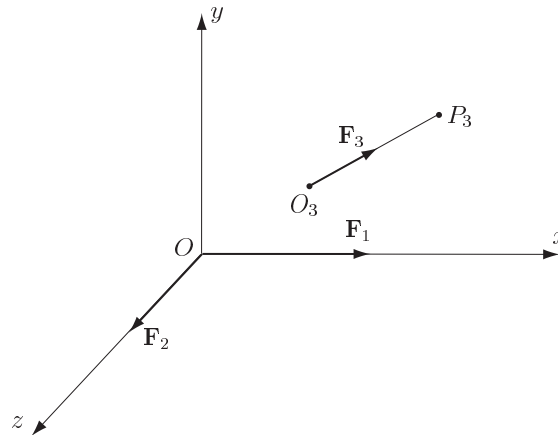

Fig. 2.12 Problem 2.2

- 2.3 Replace the three forces \mathbf{F}_1 , \mathbf{F}_2 , and \mathbf{F}_3 , shown in Fig. 2.13, by a resultant force \mathbf{R} through O and a couple. The force \mathbf{F}_2 acts along the x -axis, the force \mathbf{F}_1 is parallel with the y -axis, and the force \mathbf{F}_3 is parallel with the z -axis. The application point of the forces \mathbf{F}_2 is O , the application point of the forces \mathbf{F}_1 is B , and the application points of the force \mathbf{F}_3 is A . The distance between O and A is d_1 and the distance between A and B is d_2 as shown in Fig. 2.13.
 Numerical application: $|\mathbf{F}_1| = F_1 = 250$ N, $|\mathbf{F}_2| = F_2 = 300$ N, $|\mathbf{F}_3| = F_3 = 400$ N, $d_1 = 1.5$ m and $d_2 = 2$ m.
- 2.4 Two forces \mathbf{F}_1 and \mathbf{F}_2 and a couple of moment M in the xy plane are given. The force $\mathbf{F}_1 = F_{1x}\mathbf{i} + F_{1y}\mathbf{j} + F_{1z}\mathbf{k}$ acts at the point $P_1 = P_1(x_1, y_1, z_1)$ and the force $\mathbf{F}_2 = F_{2x}\mathbf{i} + F_{2y}\mathbf{j} + F_{2z}\mathbf{k}$ acts at the point $P_2 = P_2(x_2, y_2, z_2)$. Find the resultant force-couple system.

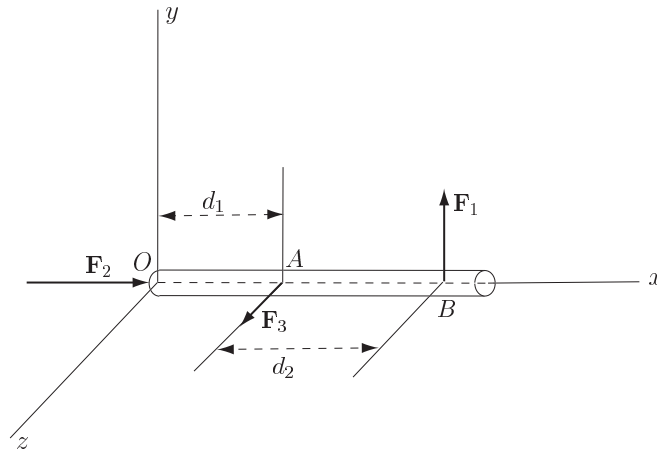

Fig. 2.13 Problem 2.3

Numerical application: $F_{1x} = 10$, $F_{1y} = 5$, $F_{1z} = 40$, $F_{2x} = 30$, $F_{2y} = 10$, $F_{2z} = -30$, $F_{3x} = 7$, $F_{3y} = -6$, $F_{3z} = 5$, $P_1 = P_1(0, 1, -1)$, $P_2 = P_2(1, 1, 1)$ and $M = -30$ N·m. The units for the forces are in Newtons and for the coordinates are given in meters.

- 2.5 Replace the three forces \mathbf{F}_1 , \mathbf{F}_2 , and \mathbf{F}_3 , shown in Fig. 2.14, by a resultant force at the origin O of the reference frame and a couple. The force \mathbf{F}_1 acts along the x -axis, the force \mathbf{F}_2 is parallel with the z -axis, and the force \mathbf{F}_3 is parallel with the y -axis. The application point of the force \mathbf{F}_1 is at O , the application point of the forces \mathbf{F}_2 is at A , and the application points of the force \mathbf{F}_3 is at B . The distance between the origin O and the point A is d_1 and the distance between the point A and the point B is d_2 . The line AB is parallel with the z -axis.

Numerical application: $|\mathbf{F}_1| = F_1 = 50$ N, $|\mathbf{F}_2| = F_2 = 30$ N, $|\mathbf{F}_3| = F_3 = 60$ N, $d_1 = 1$ m and $d_2 = 0.7$ m

- 2.6 Three forces \mathbf{F}_1 , \mathbf{F}_2 and \mathbf{F}_3 act on a beam as shown in Fig. 2.15. The directions of the forces are parallel with y -axis. The application points of the forces are P_1 , P_2 , and P_3 , and the distances $AP_1 = d_1$, $P_1P_2 = d_2$, $P_2P_3 = d_3$ and $P_3B = d_4$ are given.

a) Find the resultant of the system.

b) Resolve this resultant into two components at the points A and B .

Numerical application: $|\mathbf{F}_1| = F_1 = 30$ N, $|\mathbf{F}_2| = F_2 = 60$ N, $|\mathbf{F}_3| = F_3 = 50$ N, $d_1 = 0.1$ m, $d_2 = 0.3$ m, $d_3 = 0.4$ m and $d_4 = 0.4$ m.

- 2.7 A force \mathbf{F} acts vertically downward, parallel to the y -axis, and intersects the xz plane at the point $P_1(x_1, y_1, z_1)$. Resolve this force into three parallel components acting at the points $P_2 = P_2(x_2, y_2, z_2)$, $P_3 = P_3(x_3, y_3, z_3)$ and $P_4 = P_4(x_4, y_4, z_4)$.

Numerical application: $|\mathbf{F}_1| = F_1 = 50$ N, $P_1 = P_1(2, 0, 4)$, $P_2 = P_2(0, 0, 0)$, $P_3 = P_3(6, 0, 0)$, $P_4 = P_4(0, 0, 3)$. The coordinates are given in meters.

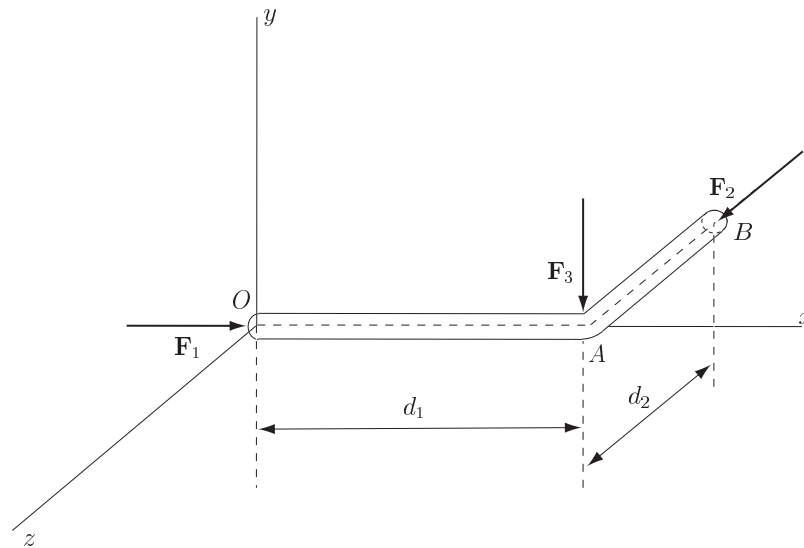

Fig. 2.14 Problem 2.5

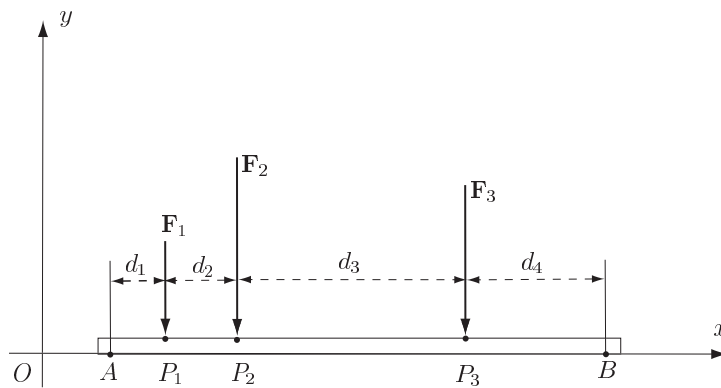
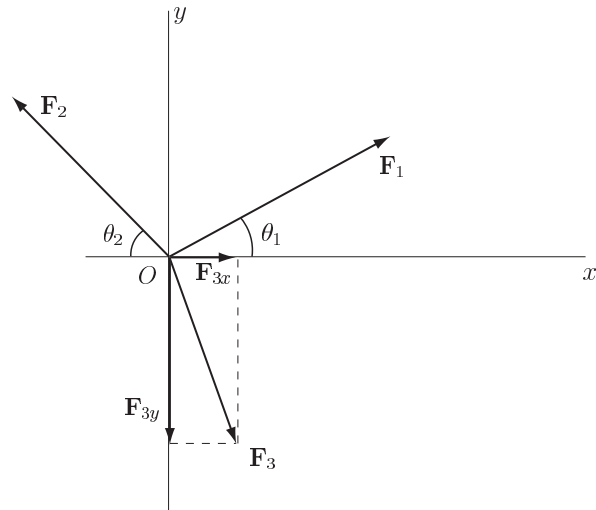

Fig. 2.15 Problem 2.6

- 2.8 Determine the resultant of the given system of forces \mathbf{F}_1 , \mathbf{F}_2 , and \mathbf{F}_3 , shown in the Fig. 2.16. The angle between the direction of the force \mathbf{F}_1 and the Ox axis is θ_1 and the angle between the direction of the force \mathbf{F}_2 with the Ox axis is θ_2 . The x and y components of the force $\mathbf{F}_3 = |\mathbf{F}_{3x}|\mathbf{i} + |\mathbf{F}_{3y}|\mathbf{j} = F_{3x}\mathbf{i} + F_{3y}\mathbf{j}$ are given.
 Numerical application: $|\mathbf{F}_1| = F_1 = 250$ N, $|\mathbf{F}_2| = F_2 = 220$ N, $|\mathbf{F}_{3x}| = F_{3x} = 50$ N, $|\mathbf{F}_{3y}| = F_{3y} = -120$ N, $\theta_1 = 30^\circ$, $\theta_2 = 45^\circ$.

**Fig. 2.16** Problem 2.8