

# Integrated Facility Design using an Evolutionary Approach with a Subordinate Network Algorithm

Bryan A. Norman, Alice E. Smith and Rifat Aykut Arapoglu

Department of Industrial Engineering  
University of Pittsburgh  
Pittsburgh, PA 15261 USA  
[banorman@engrng.pitt.edu](mailto:banorman@engrng.pitt.edu) or [aesmith@engrng.pitt.edu](mailto:aesmith@engrng.pitt.edu)

**Abstract.** The facility design problem is a common one in manufacturing and service industries and has been studied extensively in the literature. However, restrictions on the scope of the design problem have been imposed by the limitations of the optimization techniques employed. This paper uses an evolutionary approach with a subordinate network optimization algorithm to produce integrated designs that have better translations into physical plant designs. A new distance metric to consider material travel along the perimeter of the departments to and from input/output locations is devised. This perimeter distance metric is used in the objective function to produce facility designs that simultaneously optimize design of department shapes, department placement and location of the department input/output points.

## 1. Introduction

Facility design problems are a family of design problems involving the partitioning of a planar region into departments or work centers of given area, so as to minimize the costs associated with projected interactions between departments. These costs usually reflect material handling costs among departments. Such problems occur in many organizations, including manufacturing cell design, hospital design, and service center design. By any monetary measure, facilities design is an important problem and one that has assumed even greater importance as manufacturers strive to become more agile and responsive (Tompkins, 1997). For U.S. manufacturers, between 20% to 50% of total operating expenses are spent on material handling and an appropriate facilities design can reduce these costs by at least 10% to 30% (Meller and Gau, 1996). Dr. James A. Tompkins, one of the seminal researchers in the field, recently wrote, "Since 1955, approximately 8 percent of the U.S. GNP has been spent annually on new facilities. In addition, existing facilities must be continually modified...These issues represent more than \$250 billion per year attributed to the design of facility systems, layouts, handling systems, and facilities locations..." (Tompkins, 1997). Altering facility designs due to incorrect decisions, forecasts or assumptions usually involves considerable cost, time and disruption of activities. On the other hand, good designs can reap economic and operational benefits for a long time period. Therefore,

computational time is not an important issue for these design decisions, instead the critical aspect is layouts that translate readily into physical reality and minimize material handling costs. The problem primarily studied in the literature has been “block layout” which only specifies the placement of the departments, without regard for aisle structure and material handling system, machine placement within departments or input/output (I/O) locations. Block layout is usually a precursor to these subsequent design steps, termed “detailed layout.” Two recent survey articles on the facility design problem are Kusiak and Heragu (1987) and Meller and Gau (1996).

The problem was originally formalized by Armour and Buffa (1963) as follows. There is a rectangular region,  $R$ , with fixed dimensions  $H$  and  $W$ , and a collection of  $n$  required departments, each of specified area  $a_j$  and dimensions of  $h_j$  and  $w_j$ , whose total area,  $\sum_j a_j = A = H \times W$ . There is a material flow  $F(j,k)$  associated with each pair

of departments  $(j,k)$  which generally includes a traffic volume in addition to a unit cost to transport that volume. There may also be fixed costs between departments  $j$  and  $k$ .  $F(j,k)$  might also include inter-floor costs. The objective is to partition  $R$  into  $n$  subregions representing each of the  $n$  departments, of appropriate area, in order to:

$$\min Z = \sum_{j=1}^n \sum_{\substack{k=1 \\ j \neq k}}^n F(j,k) d(j,k, \Pi) \quad (1)$$

where  $d(j,k, \Pi)$  is the distance between the centroid of department  $j$  and the centroid of department  $k$  in the partition  $\Pi$ . This centroidal distance is easy to calculate and it is intuitive in that the mass of material is considered to move between the centers of departments along the shortest rectilinear (Manhattan) or Euclidean distance. However, the centroid distance metric is not realistic in that it ignores the aisle structure that is present in all facilities, where the aisles are normally located along the departmental perimeters and connect I/O points in each department.

Because of the computational complexities in optimizing multiple and non-linear objectives and constraints, only limited work has been done to improve upon the centroid to centroid distance metric; distance along aisles (Benson and Foote, 1997 and Tretheway and Foote, 1994) and expected distance using integration (Bozer and Meller, 1997). The recent work of Benson and Foote (1997) in particular, considers the placement of aisles and I/O points *after* the relative location of the departments and the general aisle structure have been selected. Related work on integrated facility layout that considers machine placement includes papers by Nagi and others (Harhalakis, et al., 1996 and Kane and Nagi, 1997). This work uses predefined departmental shapes set on a grid covering the facility space. In Harhalakis et al. (1996), Dijkstra’s shortest path algorithm is used to calculate the rectilinear distance to and from pre-specified I/O points. In Kane and Nagi (1997), I/O points are placed during the optimization and a constraint is imposed to encourage aisles that are straight. Both papers use a simulated annealing heuristic to alter departmental placement. Another related work is by Banerjee et al. (1997) where a genetic algorithm finds a “rough” layout that is then fully defined using a subordinate mathematical programming routine. The number of I/O’s per department is pre-specified and then they are optimally located with the department placement. Rectilinear distance (but not along departmental perimeters) is calculated between I/O

points.

This paper seeks to improve upon these attempts at integrated facility design by using a perimeter distance metric. If aisles have negligible area compared to the plant area and aisle capacity and direction of flow are not considered (i.e., two way flow through each aisle is allowed), I/O points can be placed concurrently with block layout, producing a one stage optimization procedure that considers material flow from I/O to I/O along departmental perimeters. This still does not achieve the ideal situation where a true aisle structure will also be optimally designed concurrently. This simplification, instead, assumes that all department perimeters are legitimate aisles.

## 2. Formulation and Solution Methodology

The basic assumption is that the departments must be rectangular, of specified area, and fit within a rectangular bounding facility that is equal to, or larger than, the sum of the departmental areas. The formulation used is “flexbay” of Tate and Smith (1993, 1995) that is a more restrictive version of a slicing tree formulation (Tam, 1992a and 1992b) (see Figure 1). Flexbay makes cuts in a single direction to establish a set of bays that can vary in area. The bays are then subdivided into departments. The flexbay encoding can enforce both departmental areas and departmental shapes, through use of a maximum aspect ratio constraint<sup>1</sup> or a minimum departmental side length constraint for a stated department area. The flexbay approach can only design departments that are rectangular; therefore any irregular departments would have to somehow be cast as rectangular components.

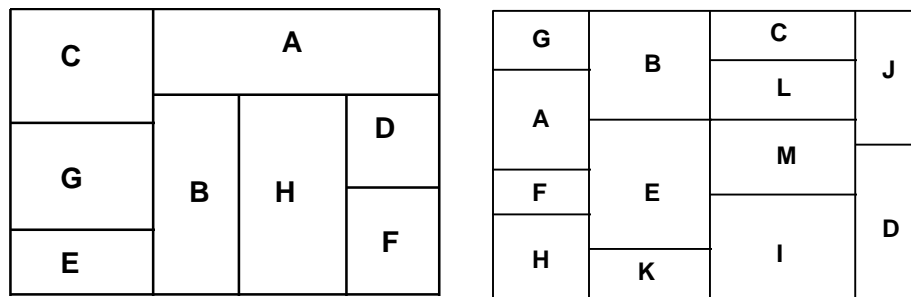

Fig. 1. Typical slicing tree (left) and flexbay (right) layouts

### 2.1 The Evolutionary Approach

To find the optimal or near-optimal block layout, a genetic algorithm (GA) is used

<sup>1</sup> Aspect ratio is the ratio of the longer side to the shorter side of a department.

with the flexbay formulation. The genetic algorithm works with a variable length encoding of the layout where there is a one to one correspondence between each encoding and each layout, excepting mirror image layouts. The encoding is a permutation of departments that specifies their order within the layout, with a concatenated string indicating where the bay breaks within the permutation occur. For example, the flexbay layout of Figure 1 would be represented with the following encoding:

G A F H B E K C L M I J D H K I

where the last three characters indicate bay breaks after departments H, K and I. While the number of departments in the string is fixed, the number of bay breaks is not, and may assume any value from zero (no bay breaks) to  $n$  (the number of departments).

Crossover is accomplished through a variant of uniform crossover, where two parents create one offspring. The department sequence is subject to uniform crossover with repair to ensure feasible permutations. The bay structure is taken directly from one parent or the other with equal probability. Mutation consists of permutation altering (50%), or adding (25%) or deleting (25%) a bay break. The permutation mutation is inversion between two randomly selected departments in the permutation. Crossover and mutation are performed independently of each other, with all solutions (parents and offspring) currently available equally likely to be mutated. This independence strategy was noted by Reeves (1997) to hold potential as a general GA strategy. Solutions are selected for crossover using a rank-based quadratic method and a constant population size is maintained. Tate and Smith (1995) includes the details of these.

## 2.2 I/O Location and Distance Metric in the Objective Function

The version of I/O location that is considered in this paper is where unlimited I/O's per department are allowed. This might seem unrealistic, but due to the perimeter metric, it can be readily verified that the set of candidate I/O points for a department can be limited to those locations where that department intersects the corner of any adjacent department. This set of I/O points represents a dominant set and therefore the algorithm can be limited to consider only these points as potential I/O locations. Because of the flexible bay construct, the number of I/O points can be further bounded to  $2n-2$  and does not depend on bay structure (Norman et al., in review). Using the example of Figure 1, the candidate I/O points would be as shown in Figure 2 on the left. To clarify the perimeter distance metric, if the I/O's used were as shown in Figure 2 on the right, the material will traverse over the perimeters shown in the dashed lines.

If each department can have an unconstrained number of I/O stations then the interdepartmental aisle travel distances can be found by formulating this problem as one of finding the shortest path on a network. The flexbay representation facilitates the development of this model due to the inherent bay structure imposed on the layout. All of the arc lengths in the resulting shortest path problem will be positive since they

represent physical distances. The shortest path problem with positive arc lengths has been well studied in the network optimization literature and efficient algorithms exist for solving this problem exactly (Ahuja et al., 1993). This makes it possible to quickly evaluate the actual aisle travel distance for each layout that is generated during the search process as a subordinate call from the GA.

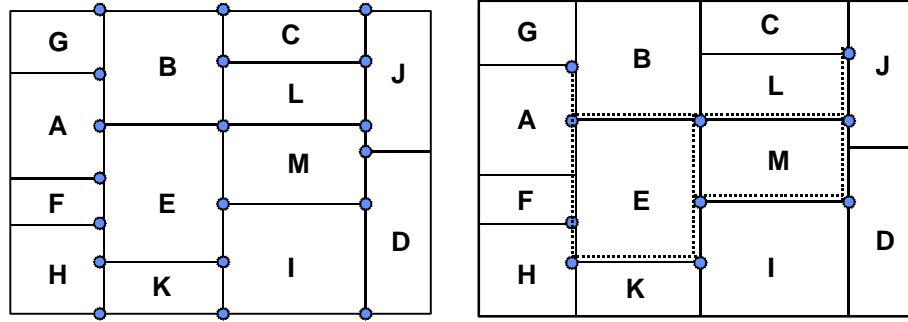

Fig. 2. Possible I/O points on a flexbay layout (left) and material flow (right)

The objective function of the GA is:

$$Z(\Pi) = \sum_{j=1}^n \sum_{\substack{k=1 \\ j \neq k}}^n F_{j,k} d_{j,k} + m^3 (Z_{feas} - Z_{all}) \quad (2)$$

where  $m$  is the number of departments in layout  $\Pi$  which violate the aspect ratio or minimum side length constraint,  $Z_{feas}$  is the objective function value for the best feasible solution found so far, and  $Z_{all}$  is the unpenalized objective function value for the best solution found so far. In this case  $d_{j,k}$  is defined as the shortest rectilinear distance along departmental perimeters between the I/O stations of departments  $j$  and  $k$  as found by the subordinate network optimization. The penalty function is a variation of the adaptive one proposed by Smith and others (Coit et al., 1996, Smith and Coit, 1997, Smith and Tate, 1993). It has the property of self-scaling by using feedback during the search on the relative difference between the best feasible and infeasible solutions, and includes a distance metric to feasibility (in this case, the number of infeasible departments in the layout). Of course when  $m = 0$  (no departments violate the aspect ratio constraint) the objective function is simply the summed rectilinear distances between I/Os along department perimeters times the flow quantities between each pair of departments.

The flow of the algorithm is shown below in pseudocode:

1. Randomly initialize the population of chromosomes
2. For  $j = 1$  to the maximum number of generations
  - a) Select two parent chromosomes based on ranked fitness and perform uniform crossover with repair to produce one offspring

- b) Call evaluation routine for offspring
- c) Replace the worst chromosome in the current population with the offspring
- d) Randomly select  $M$  chromosomes<sup>2</sup> for mutation using the mutation rate and perform mutation
- e) Call evaluation routine for mutants
- f) Replace the  $M$  worst chromosomes with the mutants

#### Evaluation Routine

- 1) Determine the current facility design from the chromosome
- 2) Calculate the number of infeasible departments,  $m$
- 3) Construct a network of nodes corresponding to each department in the design and its candidate I/O locations
- 4) Find the shortest path between each pair of nodes in the network using the Floyd-Warshall algorithm (Ajuha et al., 1993)
- 5) Using these shortest path distances, calculate the objective value using equation 2

### 3. Test Problems and Results

Several problems from the literature were solved in the manner described in Section 2. While the material flows, departmental areas and constraints are identical to those previously studied, results cannot be compared directly as the distance metric used previously was the centroid to centroid. The problems are from Bazaraa (Bazaraa, 1975 and Hassan et al., 1986) (14 departments) and Armour and Buffa (1963) (20 departments). The GA settings were the same as in Tate and Smith (1995): population size of 10, mutation rate of 50% and number of solutions (offspring and mutants) generated = 600,000. While the small population size and large mutation rate are nonstandard in the GA literature, for this implementation, larger population sizes and / or reduced mutation rates were not superior. A variety of GA parameter settings were explored, and while the search was not particularly sensitive to alterations in the parameters, the combination used in the research herein was the most effective. The number of solutions generated that is needed to adequately explore the search space is dependent strongly on the number of departments,  $n$ . The 600,000 value was appropriate for the larger Armour and Buffa problem while the smaller Bazaraa problem converged in much fewer number of solutions searched.

Objective function values from the perimeter metric are in Table 1, where the best, median, worst and standard deviation over ten random seeds are shown. The twenty department Armour and Buffa (A&B) problem was studied with maximum aspect ratios of 10, 7, 5, 4, 3 and 2, which represent problems ranging from lightly constrained to extremely constrained. The Bazaraa problem used a maximum side

---

<sup>2</sup>  $M$  is upper bounded by at least one less than the population size, creating an elitist GA.

length of one as the shape constraint as done by previous authors. For comparison using the Bazaraa 14 problem, the best design using the perimeter metric is shown compared to the best layout from Tate and Smith (1995) using the rectilinear centroid to centroid distance metric in Figure 3. Also shown are the I/O points and the material flow paths inherent in each formulation. Note that department 14 (shaded) is a “dummy” department with no flows, hence the lack of an I/O. It appears that the perimeter metric with I/O location on the boundaries of the departments is a better reflection of the physical movement of material for most manufacturing and service scenarios. The centroid method not only traverses through the interior of intervening departments, it assumes the minimum rectilinear distance between pairs of departments, creating nearby parallel paths as seen in departments 5 and 6. Designs where the centroids are not located along the same line (as they are in departments 1 through 4) would create even more paths. This is shown in Figure 4, the Armour & Buffa problem with aspect ratio constraint of 3, for the best Tate and Smith (1995) layout and the best of this research. As a further comparison of the merit of concurrently optimizing both department layout and I/O placement, the objective function (equation 2) was calculated for the best layouts from Tate and Smith (1995) (Figures 3 and 4 top, respectively). I/Os were placed on these layouts using the shortest path algorithm. The values of equation 2 were 2847.1 and 997.8 (Bazaraa and Armour and Buffa, respectively), which compares with the values of 1343.2 and 942.6 for the concurrent approach of this paper. Therefore, performing the optimization separately (first, the block layout, then the I/O and routing) results in designs that are generally inferior to those found by combining the steps during optimization.

**Table 1.** Comparisons of results over ten seeds

| <b>Problem</b> | <b>Best</b> | <b>Median</b> | <b>Worst</b> | <b>Standard Deviation</b> |
|----------------|-------------|---------------|--------------|---------------------------|
| Bazaraa 14     | 1343.2      | 1459.2        | 1607.9       | 92.8                      |
| A&B 20/10      | 757.1       | 862.9         | 1221.0       | 147.2                     |
| A&B 20/7       | 785.8       | 1079.9        | 1267.4       | 155.2                     |
| A&B 20/5       | 949.4       | 1319.6        | 2176.4       | 343.0                     |
| A&B 20/4       | 1025.7      | 1189.2        | 1758.1       | 236.3                     |
| A&B 20/3       | 942.6       | 1478.1        | 2298.5       | 354.0                     |
| A&B 20/2*      | 1244.1      | 1873.6        | 3359.8       | 787.2                     |

\* For the six of the ten runs that found feasible layouts.

## 4. Conclusions

Using the flexible GA meta-heuristic with the very efficient subordinate exact network optimization algorithm enables effective and efficient optimization of facility designs that correspond well to physical designs. A new distance metric that more accurately reflects material handling costs than does the popular departmental centroid to centroid distance metric was developed. The perimeter distance metric is coupled with the location of the input and output locations of each department. This makes it possible to *concurrently* optimize four facets of the facility design problem:

department locations within the facility, department shapes within certain constraints, I/O placement and travel paths along the department perimeters. Since facility design has significant monetary ramifications, improved optimization approaches to more realistic, albeit more complex, formulations will result in tangible benefits over a long time horizon.

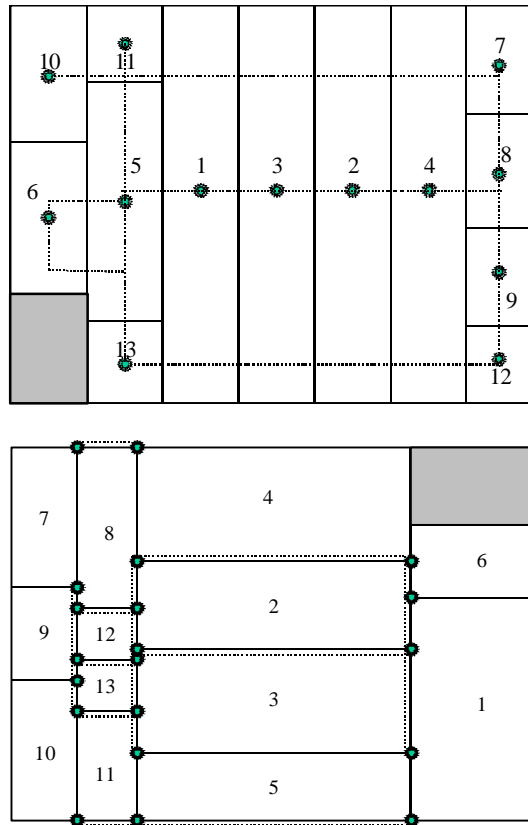

**Fig. 3.** I/O points and flow paths (dashed) for the centroid distance metric (top) and the perimeter distance metric (bottom) for the Bazarra 14 problem

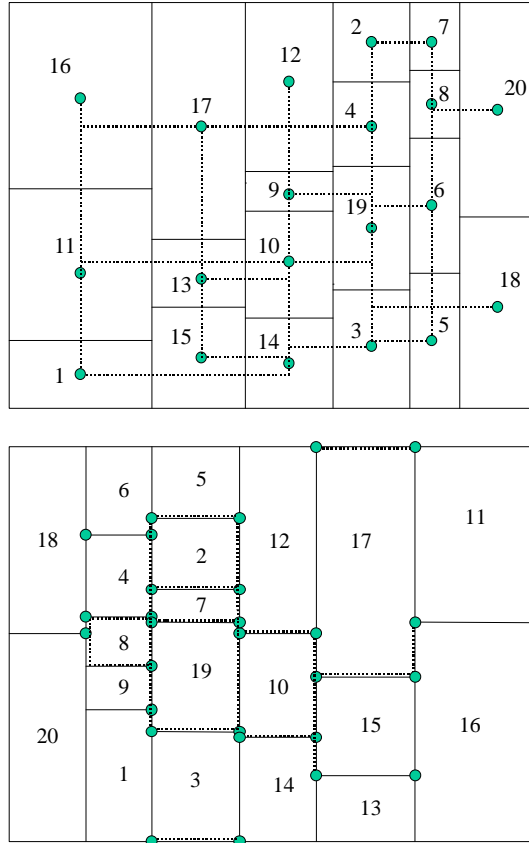

**Fig. 4.** I/O points and flow paths (dashed) for the centroid distance metric (top) and the perimeter distance metric (bottom) for the Armour and Buffa problem with aspect ratio constraint of 3

## Acknowledgment

Alice E. Smith gratefully acknowledges the support of the U.S. National Science Foundation CAREER grant DMI 95-02134.

## References

1. Ahuja, R. K., Magnanti, T. L., Orlin, J. B.: *Network Flows: Theory, Algorithms, and*

- Applications*, Prentice-Hall, Upper Saddle, NJ (1993)
2. Armour, G. C., Buffa, E. S.: *A Heuristic Algorithm and Simulation Approach to Relative Allocation of Facilities*. *Management Science* (9) (1963) 294-309
  3. Banerjee, P., Zhou, Y., Montreuil, B.: *Genetically Assisted Optimization of Cell Layout and Material Flow Path Skeleton*. *IIE Transactions* (29) (1997) 277-291
  4. Bazaraa, M. S.: *Computerized Layout Design: A Branch and Bound Approach*. *AIIE Transactions* (7) (1975) 432-438
  5. Benson, B., Foote, B. L.: *Door FAST: A Constructive Procedure to Optimally Layout a Facility Including Aisles and Door Locations Based on an Aisle Flow Distance Metric*. *International Journal of Production Research* (35) (1997) 1825-1842.
  6. Bozer, Y. A., Meller, R. D.: *A Reexamination of the Distance-based Facility Layout Problem*. *IIE Transactions* (29) (1997) 549-560
  7. Coit, D. W., Smith, A. E., Tate, D. M.: *Adaptive Penalty Methods for Genetic Optimization of Constrained Combinatorial Problems*. *INFORMS Journal on Computing* (8) (1996) 173-182
  8. Harhalakis, G., Lu, T., Minis, I., Nagi, R.: *A Practical Method for Design of Hybrid-type Production Facilities*. *International Journal of Production Research* (34) (1996) 897-918
  9. Hassan, M. M. D., Hogg, G. L., Smith, D. R.: *Shape: A Construction Algorithm for Area Placement Evaluation*. *International Journal of Production Research* (24) (1986) 1283-1295
  10. Kane, M. C., Nagi, R.: *Integrated Material Flow and Layout in Facilities Design*. In *Proceedings of the Sixth Industrial Engineering Research Conference*, Miami FL (May 1997) 919-924
  11. Kusiak, A., Heragu, S. S.: *The Facility Layout Problem*. *European Journal of Operational Research* (29) (1987) 229-251
  12. Meller, R. D., Gau, K.-Y.: *The Facility Layout Problem: Recent and Emerging Trends and Perspectives*. *Journal of Manufacturing Systems* (15) (1996) 351-366
  13. Norman, B. A., Smith, A. E., Arapoglu, R. A.: *Integrated Facilities Layout Using a Perimeter Distance Measure*. *IIE Transactions*, in review
  14. Reeves, C. R.: *Genetic Algorithms for the Operations Researcher*. *INFORMS Journal on Computing* (9) (1997) 231-250.
  15. Smith, A. E., Coit, D. W.: *Constraint-Handling Techniques - Penalty Functions*. In *Handbook of Evolutionary Computation*, Institute of Physics Publishing and Oxford University Press, Bristol, U.K. (1997) Chapter C5.2
  16. Smith, A. E., Tate, D. M.: *Genetic Optimization using a Penalty Function*. In *Proceedings of the Fifth International Conference on Genetic Algorithms*, Urbana, IL (July 1993) 499-505
  17. Tam, K. Y.: *Genetic Algorithms, Function Optimization, and Facility Layout Design*. *European Journal of Operational Research* (63) (1992a) 322-346
  18. Tam, K. Y.: *A Simulated Annealing Algorithm for Allocating Space to Manufacturing Cells*. *International Journal of Production Research* (30) (1992b) 63-87
  19. Tate, D. M., Smith, A. E.: *Genetic Algorithm Optimization Applied to Variations of the Unequal Area Facilities Layout Problem*. In *Proceedings of the Second Industrial Engineering Research Conference*, Los Angeles (May 1993). *IIE*, Atlanta (1993) 335-339
  20. Tate, D. M., Smith, A. E.: *Unequal-area Facility Layout by Genetic Search*. *IIE Transactions* (27) (1995) 465-472
  21. Tompkins, J. A.: *Facilities Planning: A Vision for the 21st Century*. *IIE Solutions* (August 1997) 18-19
  22. Tretheway, S. J., Foote, B. L.: *Automatic Computation and Drawing of Facility Layouts with Logical Aisle Structures*. *International Journal of Production Research* (32) (1994) 1545-1556